

# Technical Guide: CTF, CTM, and CTU Series - Add-On Coils for Use with Split-System Cooling and Heat Pumps

600 CFM to 2,000 CFM - 1.5 ton to 5 ton

---

York International Corporation, 5005 York Drive, Norman, OK 73069

6523695-UTG-A-0524

Supersedes: Nothing

2024-06-06

---



# Contents

Description.....	5
Certification.....	5
Features.....	5
Accessories.....	6
A2L safety considerations.....	7
Nomenclature.....	9
Dimensions: CTF coils.....	10
Dimensions: CTM coils.....	12
Dimensions: CTU coils.....	14
Cooling capacity: CTF coils.....	15
Cooling capacity: CTM coils.....	17
Cooling capacity: CTU coils.....	19
Application factors.....	20
Application limitations.....	20
Static pressure versus airflow based on wet coil: CTF coils.....	20
Static pressure versus airflow based on wet coil: CTM coils.....	22
Static pressure versus airflow based on wet coil: CTU coils.....	23
Coil technical data: CTF coils.....	24
Coil technical data: CTM coils.....	25
Coil technical data: CTU coils.....	26
Airflow data: CTF coils.....	27
Airflow data: CTM coils.....	28
Airflow data: CTU coils.....	29



## Description

MaxAlloy™ aluminum indoor coils are specially designed for installation with our residential furnaces or modular air handlers as part of a matched air conditioning or heat pump system.

Our residential indoor coils can be applied with indoor thermostatic expansion valves (TXVs) according to the application. Most indoor coil models are available as flex coils for installation of the specific expansion device in the field. Select SKUs are available with factory mounted TXVs. Refer to the *Technical Guide* for the matched outdoor unit to determine the required indoor expansion device for your specific application.

**CTF** series full-cased coils are suitable for upflow or downflow applications.

**CTM** series full-cased multi-position coils are designed for horizontal left, horizontal right, upflow, or downflow applications.

**CTU** series uncased coils are designed for upflow or downflow applications installed on the leaving air end of gas furnaces. These coils can require field modification of the ductwork.

Due to continuous product improvement, specifications are subject to change without notice. Visit us on the web at [www.simplygettingthejobdone.com](http://www.simplygettingthejobdone.com). Additional rating information can be found at [www.ahridirectory.org](http://www.ahridirectory.org).

**This document is only for distribution use - it is not to be used at point of retail sale.**

## Certification

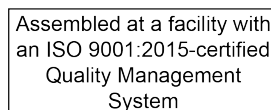

## Features

### Rigid case construction

The rigid case construction provides structural support and eliminates screw heads protruding from the side of the cabinet that could damage property during installation.

### Cabinet

The cabinet is constructed of heavy gauge galvanized steel with a primer and finish coat that provides a high-quality corrosion resistant finish.

### MaxAlloy™ coil

These long-life aluminum coils are built to deliver lasting performance, efficiency, and reliability.

### Foil-faced insulation

The cabinet is insulated with a single piece of cleanable foil-faced insulation. The cabinet is designed so that all edges of the insulation are contained.

### Compact cabinet

With the coil and access doors removed, the cabinet has a 20.5 in. casing depth in all models, allowing ease of access in attics and applications where space is constrained.

### **Thermoset drain pan**

The drain pan is corrosion and UV resistant with a positive slope for proper drainage. The low water retention design maximizes indoor air quality and consumer comfort.

### **Low leakage cabinet design**

Fully gasketed doors minimize air leakage to no more than 2% when measured at 1.0 in. W.C. external static pressure, minimizing conditioned air leakage and infiltration.

### **Duct flange**

An integral duct flange is part of the coil casing for easy installation.

### **TXV**

Select factory-installed and field-installed models are available. They use Chatleff fittings, and no brazing is required.

## **Accessories**

Refer to the *Price Manual* for specific model numbers.

### **TXV kits**

TXV kits are available for flex coil applications with R-454B refrigerant. All TXV kits are non-braze, bolt-on connections including the valve assembly and equalizer tube. Do not use an orifice or any other metering device in conjunction with the TXV.

### **A2L refrigerant detection system (RDS) kit**

The A2L RDS kit for Maxalloy coils detects any A2L leakage and ensures the safe operation of the equipment. Use the A2L RDS kit with CTF, CTM, CTU, and CXF coil models that do not have a factory-installed RDS.

# A2L safety considerations



Refrigerant  
Safety Group  
A2L

## CAUTION

### Risk of fire

This unit uses a mildly flammable (A2L) refrigerant. The unit must only be repaired or serviced by trained service personnel. Before attempting to repair or service the unit, consult the *Installation Manual*. Follow all safety precautions.

## WARNING

If the unit must be installed in a residence with a minimum room area less than what is determined to be the minimum from [Table 1](#), then that room must also not have any continuously operating open flames or other potential ignition sources. A flame-producing device may be present if that device is provided with an effective flame arrest.

**Table 1: Minimum room area**

System charge (lb-oz)	Minimum room area (ft <sup>2</sup> )	Minimum total conditioned area (ft <sup>2</sup> )	Minimum system airflow (CFM)
4-0	43	58	233
4-4	46	61	248
4-8	48	65	262
4-12	51	69	277
5-0	54	72	291
5-4	56	76	306
5-8	59	80	321
5-12	62	83	335
6-0	64	87	350
6-4	67	90	364
6-8	70	94	379
6-12	73	98	393
7-0	75	101	408
7-4	78	105	422
7-8	81	108	437
7-12	83	112	452
8-0	86	116	466
8-4	89	119	481
8-8	91	123	495
8-12	94	127	510
9-0	97	130	524
9-4	99	134	539
9-8	102	137	554
9-12	105	141	568
10-0	107	145	583
10-4	110	148	597
10-8	113	152	612
10-12	115	155	626
11-0	118	159	641
11-4	121	163	656

**Table 1: Minimum room area**

System charge (lb-oz)	Minimum room area (ft <sup>2</sup> )	Minimum total conditioned area (ft <sup>2</sup> )	Minimum system airflow (CFM)
11-8	124	166	670
11-12	126	170	685
12-0	129	173	699
12-4	132	177	714
12-8	134	181	728
12-12	137	184	743
13-0	140	188	758
13-4	142	192	772
13-8	145	195	787
13-12	148	199	801
14-0	150	202	816
14-4	153	206	830
14-8	156	210	845
14-12	158	213	860
15-0	161	217	874
15-4	164	220	889
15-8	167	224	903
15-12	169	228	918
16-0	172	231	932
16-4	175	235	947
16-8	177	239	962
16-12	180	242	976
17-0	183	246	991
17-4	185	249	1005
17-8	188	253	1020



# Nomenclature

**Table 2: Nomenclature**

Number	Category	Option	Description
1	Product type	C	Coil (indoor)
2	Coil type	T	A coil
		S	Slab coil
		X	Microchannel heat exchanger (MCHX) coil
3	Configuration	F	Full case upflow or downflow
		H	Horizontal cased
		U	Uncased upflow or downflow
		D	Horizontal duct
		M	Multi-position cased
4, 5	Nominal capacity	18	1.5 ton
		24	2 ton
		30	2.5 ton
		36	3 ton
		42	3.5 ton
		48	4 ton
		60	5 ton
6	Cabinet	A	14.5 in.
		B	17.5 in.
		C	21 in.
		D	24.5 in.
7	Refrigerant	5	R454B
8	Metering device	A-W	TXV
		1-9	EEV
		X	No valve
9	Slab size	A	2R-14-18
		B	2R-16-18
		C	2R-20-18
		D	3R-20-14
		E	3R-22-14
		F	3R-24-14
		G	3R-28-12
		H	3R-32-12
10	Accessories	S	A2L sensor
		N	None (no sensor)
11	Generation (major revision)	1	First generation
		2	Second generation
		3	Third generation
		4	Fourth generation
12	Style letter (minor revision) not used for ordering	A	Style A
		B	Style B
		C	Style C
		D	Style D

**Table 3: Model nomenclature example**

Number	1	2	3	4, 5	6	7	8	9	10	11	12
Option	C	T	F	18	A	5	A	A	S	1	A

**Example:** The CTF18A5AAS1A indoor coil is a fully cased A coil and configured for upflow or downflow. The nominal capacity is 1.5 ton. The cabinet size is 14.5 in., R-454B refrigerant is in use, and a TXV metering device is installed. The slab size is 2R-14-18. An A2L sensor is installed. CTF18A5AAS1A is a first generation, style-A model.

# Dimensions: CTF coils

Figure 1: Dimensions - CTF coils - upflow or downflow full cased coil

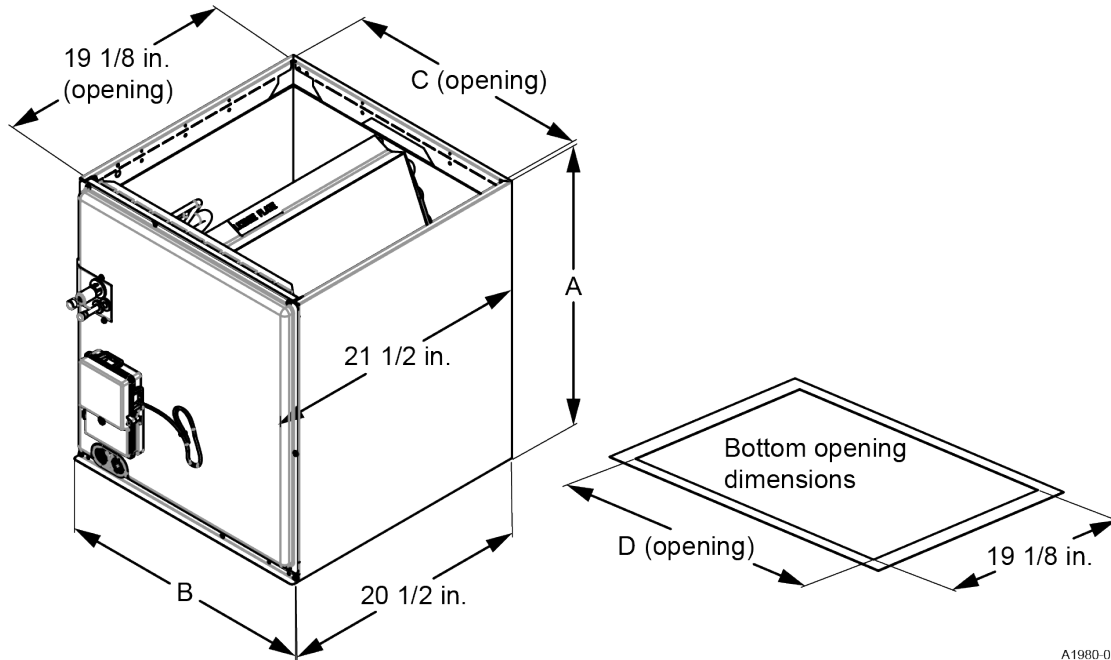

A1980-001

**Table 4: Dimensions - CTF coil - upflow or downflow full cased coil**

Model	Dimensions				Weight		Refrigerant connections line size		
	Height	Width	Opening widths		Shipping (lb)	Operating (lb)	Metering device	Liquid (in.)	Vapor (in.)
	A (in.)	B (in.)	C (in.)	D (in.)					
CTF18A5AAS1	19 1/2	14 1/2	13 1/2	13 1/2	32	31	TXV	3/8	3/4
CTF18A5AAN1	19 1/2	14 1/2	13 1/2	13 1/2	32	31	TXV		
CTF18B5AAS1	19	17 1/2	16 1/2	16 1/2	33	32	TXV		
CTF18B5AAN1	19	17 1/2	16 1/2	16 1/2	33	32	TXV		
CTF24A5ABS1	21 5/8	14 1/2	13 1/2	13 1/2	34	33	TXV		
CTF24A5ABN1	21 5/8	14 1/2	13 1/2	13 1/2	34	33	TXV		
CTF24B5ABS1	23	17 1/2	16 1/2	16 1/2	37	36	TXV		
CTF24B5ABN1	23	17 1/2	16 1/2	16 1/2	37	36	TXV		
CTF30B5ACS1	25 5/8	17 1/2	16 1/2	16 1/2	42	41	TXV		
CTF30B5ACN1	25 5/8	17 1/2	16 1/2	16 1/2	42	41	TXV		
CTF30C5ACS1	23	21	20	20	48	46	TXV		
CTF30C5ACN1	23	21	20	20	48	46	TXV		
CTF30A5ADS1	25 1/2	14 1/2	13 1/2	13 1/2	42	41	TXV		
CTF30A5ADN1	25 1/2	14 1/2	13 1/2	13 1/2	42	41	TXV		
CTF36B5ADS1	25 5/8	17 1/2	16 1/2	16 1/2	49	48	TXV		
CTF36B5ADN1	25 5/8	17 1/2	16 1/2	16 1/2	49	48	TXV		
CTF36B5CDS1	25 5/8	17 1/2	16 1/2	16 1/2	49	48	TXV		
CTF36B5CDN1	25 5/8	17 1/2	16 1/2	16 1/2	49	48	TXV		
CTF36C5CDS1	23	21	20	20	49	47	TXV		
CTF36C5CDN1	23	21	20	20	49	47	TXV		
CTF36B5CES1	25 5/8	17 1/2	16 1/2	16 1/2	51	50	TXV		
CTF36B5CEN1	25 5/8	17 1/2	16 1/2	16 1/2	51	50	TXV		
CTF42C5AES1	25	21	20	20	54	52	TXV		
CTF42C5CES1	25	21	20	20	54	52	TXV		
CTF48C5AFS1	27	21	20	20	57	55	TXV		
CTF48C5CFS1	27	21	20	20	57	55	TXV		
CTF48D5CFS1	27	24 1/2	23 1/2	23 1/2	60	58	TXV		
CTF60C5CGS1	33	21	20	20	66	64	TXV		
CTF60D5CGS1	32 3/4	24 1/2	23 1/2	23 1/2	68	66	TXV		
CTF60C5CHS1	37 1/4	21	20	20	72	70	TXV		
CTF60D5CHS1	37 1/4	24 1/2	23 1/2	23 1/2	76	74	TXV		
CTF60D5CJS1	32 3/4	24 1/2	23 1/2	23 1/2	75	73	TXV		

① **Note:** For refrigerant connections, note the following:

- Refrigerant line sizes may require larger lines for extended line lengths. Refer to *Application Data part number 247077*.
- A field-supplied adapter fitting must be field installed for any refrigeration piping sizes not shown in the table.
- Refer to the *Technical Guide* for the outdoor unit for the correct refrigeration piping size.

## Dimensions: CTM coils

Figure 2: Dimensions - CTM full-cased upflow, downflow, horizontal left, or horizontal right coil

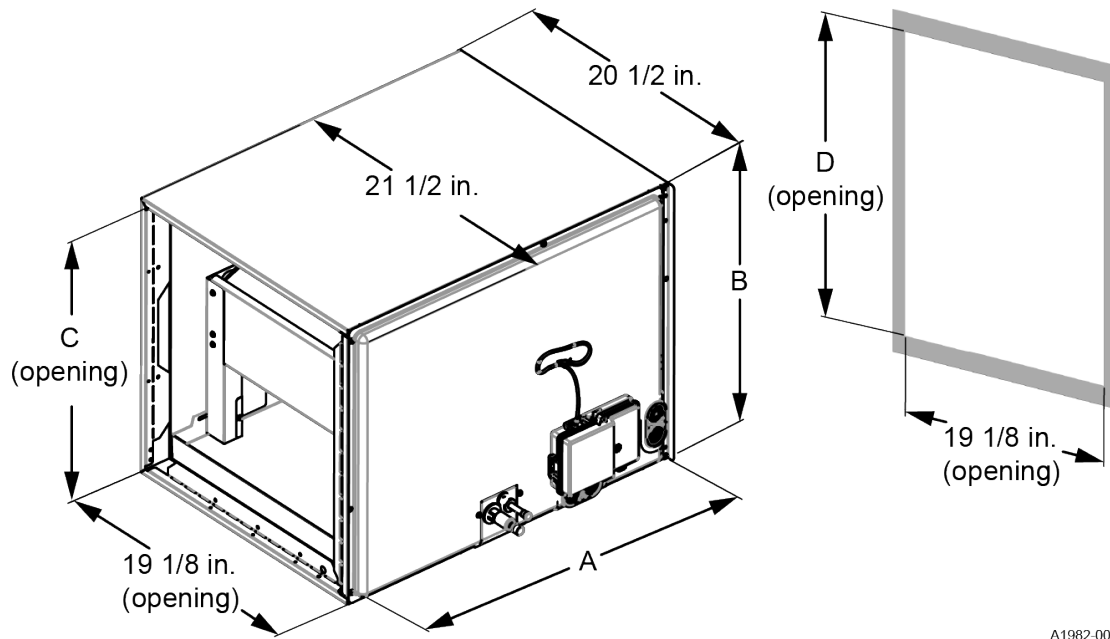

**Table 5: Dimensions - CTM full-cased upflow, downflow, horizontal left, or horizontal right coil**

Model	Dimensions				Weight		Metering device	Refrigerant connections line size	
	Height	Width	Opening widths		Shipping (lb)	Operating (lb)		Liquid	Vapor
	A (in.)	B (in.)	C (in.)	D (in.)					
CTM18A5AAS1	23	14 1/2	13 1/2	13 1/2	39	38	TXV	3/8	3/4
CTM18A5AAN1	23	14 1/2	13 1/2	13 1/2	39	38	TXV		
CTM24A5ABS1	23	14 1/2	13 1/2	13 1/2	41	40	TXV		
CTM24A5ABN1	23	14 1/2	13 1/2	13 1/2	41	40	TXV		
CTM24B5ABS1	23	17 1/2	16 1/2	16 1/2	39	38	TXV		
CTM24B5ABN1	23	17 1/2	16 1/2	16 1/2	39	38	TXV		
CTM30B5ACS1	25 5/8	17 1/2	16 1/2	16 1/2	45	44	TXV		
CTM30B5ACN1	25 5/8	17 1/2	16 1/2	16 1/2	45	44	TXV		
CTM30C5ACS1	27	21	20	20	54	53	TXV		
CTM30C5ACN1	27	21	20	20	54	53	TXV		
CTM36B5ADS1	25 5/8	17 1/2	16 1/2	16 1/2	52	50	TXV		
CTM36B5ADN1	25 5/8	17 1/2	16 1/2	16 1/2	52	50	TXV		
CTM36B5CDS1	25 5/8	17 1/2	16 1/2	16 1/2	52	50	TXV		
CTM36B5CDN1	25 5/8	17 1/2	16 1/2	16 1/2	52	50	TXV		
CTM36C5CDS1	27	21	20	20	60	58	TXV		
CTM36C5CDN1	27	21	20	20	60	58	TXV		
CTM42C5AES1	28 3/4	21	20	20	64	62	TXV		
CTM42C5CES1	28 3/4	21	20	20	64	62	TXV		
CTM48C5CFS1	33	21	20	20	75	73	TXV		
CTM48D5CFS1	32 3/4	24 1/2	23 1/2	23 1/2	82	80	TXV		
CTM60C5CGS1	37 1/4	21	20	20	70	68	TXV		
CTM60D5CGS1	37 1/4	24 1/2	23 1/2	23 1/2	74	72	TXV		
CTM60C5CHS1	39	21	20	20	80	78	TXV		
CTM60D5CHS1	39	24 1/2	23 1/2	23 1/2	86	84	TXV		
CTM60D5CJS1	37 1/4	24 1/2	23 1/2	23 1/2	85	83	TXV		

① **Note:** For refrigerant connections, note the following:

- Refrigerant line sizes may require larger lines for extended line lengths. Refer to *Application Data part number 247077*.
- A field-supplied adapter fitting must be field installed for any refrigeration piping sizes not shown in the table.
- Refer to the *Technical Guide* for the outdoor unit for the correct refrigeration piping size.

## Dimensions: CTU coils

Figure 3: Dimensions - CTU coil - uncased upflow or downflow coil

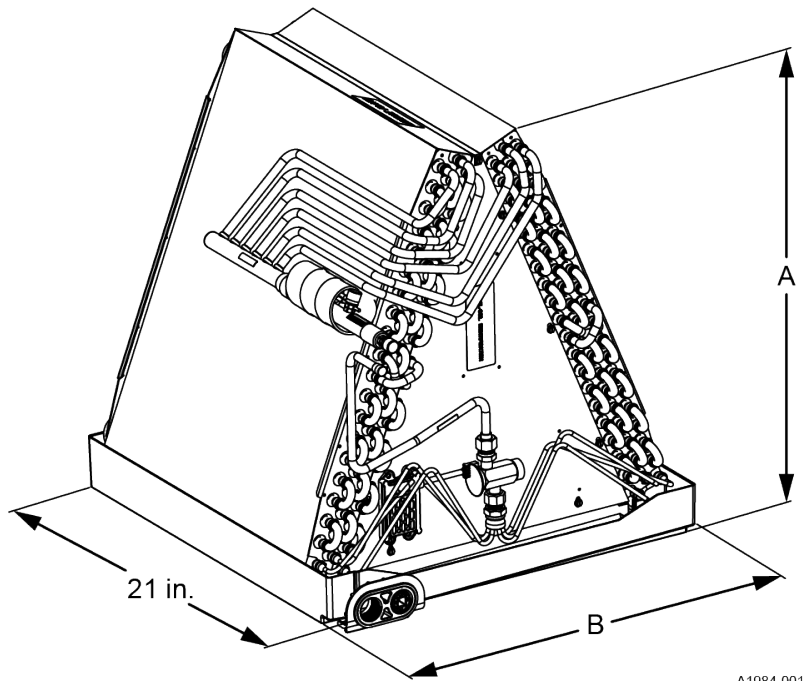

Table 6: Dimensions - CTU coil - uncased upflow or downflow coil

Model	Dimensions		Weight		Metering device	Refrigerant connections line size		
	Height	Width	Shipping (lb)	Operating (lb)		Liquid (in.)	Vapor (in.)	
	A (in.)	B (in.)						
CTU18A5XAS1	16 5/8	13	17	16	Flex	3/8	3/4	
CTU24A5XBS1	18 3/4	13	19	18	Flex			
CTU30B5XCS1	21 1/4	16	21	20	Flex			
CTU36B5XDS1	21 1/2	16	27	26	Flex			
CTU42C5XES1	23	19 1/2	30	28	Flex			7/8
CTU48C5XFS1	25	19 1/2	33	31	Flex			
CTU60C5XGS1	29 1/4	19 1/2	36	34	Flex			
CTU60D5XGS1	28 3/4	23	40	38	Flex			
CTU60D5XHS1	33	23	45	43	Flex			

- ① **Note:** For refrigerant connections, note the following:
- Refrigerant line sizes may require larger lines for extended line lengths. Refer to *Application Data part number 247077*.
  - A field-supplied adapter fitting must be field installed for any refrigeration piping sizes not shown in the table.
  - Refer to the *Technical Guide* for the outdoor unit for the correct refrigeration piping size.

## Cooling capacity: CTF coils

**Table 7: Cooling capacity - CTF (coil only)**

Model	Rated CFM	Entering air dry bulb/wet bulb (°F)	MBH at evaporation temperature and corresponding R-410A pressure (°F/psig)			
			35/107.9	40/118.9	45/130.7	50/143.3
CTF18A5*A	600	85/72	43.1	38.6	33.4	27.9
		80/67	35.0	30.3	25.2	19.6
		75/62	27.5	22.8	17.8	11.9
		70/57	20.8	16.1	11.0	8.5
CTF18B5*A	600	85/72	43.1	38.6	33.4	27.9
		80/67	35.0	30.3	25.2	19.6
		75/62	27.5	22.8	17.8	11.9
		70/57	20.8	16.1	11.0	8.5
CTF24A5*B	800	85/72	56.0	50.0	43.3	35.9
		80/67	45.5	39.5	32.6	25.2
		75/62	36.0	29.8	23.0	15.4
		70/57	27.3	21.0	14.8	11.4
CTF24B5*B	800	85/72	56.0	50.0	43.3	35.9
		80/67	45.5	39.5	32.6	25.2
		75/62	36.0	29.8	23.0	15.4
		70/57	27.3	21.0	14.8	11.4
CTF30B5*C	1000	85/72	66.1	60.1	52.9	44.6
		80/67	54.6	48.2	40.2	31.9
		75/62	43.9	36.9	29.1	19.0
		70/57	33.8	26.6	19.0	14.8
CTF30C5*C	1000	85/72	66.1	60.1	52.9	44.6
		80/67	54.6	48.2	40.2	31.9
		75/62	43.9	36.9	29.1	19.0
		70/57	33.8	26.6	19.0	14.8
CTF30A5*D	1000	85/72	72.4	65.0	56.6	47.2
		80/67	59.0	51.4	42.7	33.2
		75/62	46.8	39.0	30.2	19.9
		70/57	35.6	27.4	19.2	14.8
CTF36B5*D	1200	85/72	86.0	77.6	68.0	57.1
		80/67	70.6	61.7	52.0	40.7
		75/62	56.4	47.2	37.2	24.7
		70/57	43.1	33.8	23.9	18.6
CTF36C5*D	1200	85/72	86.0	77.6	68.0	57.1
		80/67	70.6	61.7	52.0	40.7
		75/62	56.4	47.2	37.2	24.7
		70/57	43.1	33.8	23.9	18.6
CTF36B5*E	1200	85/72	85.2	77.0	67.7	57.2
		80/67	70.2	61.5	51.9	41.1
		75/62	56.3	47.1	37.3	25.1
		70/57	43.2	34.0	24.0	18.9
CTF42C5*E	1400	85/72	93.5	84.6	74.6	62.9
		80/67	77.1	67.8	57.4	45.4
		75/62	62.0	52.2	41.5	27.3
		70/57	47.8	37.8	27.1	21.3
CTF48C5*F	1600	85/72	95.4	86.1	75.5	63.0
		80/67	78.5	68.7	57.7	45.0
		75/62	62.9	44.6	41.5	27.7
		70/57	48.4	38.1	27.5	21.0

**Table 7: Cooling capacity - CTF (coil only)**

Model	Rated CFM	Entering air dry bulb/wet bulb (°F)	MBH at evaporation temperature and corresponding R-410A pressure (°F/psig)			
			35/107.9	40/118.9	45/130.7	50/143.3
CTF48D5*F	1600	85/72	95.4	86.1	75.5	63.0
		80/67	78.5	68.7	57.7	45.0
		75/62	62.9	44.6	41.5	27.7
		70/57	48.4	38.1	27.5	21.0
CTF60C5*G	1600	85/72	115.6	104.2	91.0	76.2
		80/67	94.9	82.8	67.4	54.3
		75/62	75.6	63.1	49.4	33.6
		70/57	57.9	45.1	32.1	24.8
CTF60D5*G	1800	85/72	115.6	104.2	91.0	76.2
		80/67	94.9	82.8	67.4	54.3
		75/62	75.6	63.1	49.4	33.6
		70/57	57.9	45.1	32.1	24.8
CTF60C5*H	1800	85/72	113.0	102.6	90.1	75.7
		80/67	93.2	82.1	68.8	54.3
		75/62	74.7	62.9	49.4	33.4
		70/57	57.5	45.1	32.2	25.1
CTF60D5*H	1800	85/72	113.0	102.6	90.1	75.7
		80/67	93.2	82.1	68.8	54.3
		75/62	74.7	62.9	49.4	33.4
		70/57	57.5	45.1	32.2	25.1
CTF60D5*J	1800	85/72	111.3	100.0	87.1	72.3
		80/67	91.5	79.6	66.3	51.3
		75/62	73.1	60.9	46.9	32.6
		70/57	56.1	43.0	32.5	25.0

① **Note:** The table shows coil only data. Refer to the condensing unit or heat pump *Technical Guide* for the total cooling capacity and sensible capacity.



## Cooling capacity: CTM coils

**Table 8: Cooling capacity - CTM coil (coil only)**

Model	Rated CFM	Entering air dry bulb/wet bulb (°F)	MBH at evaporation temperature and corresponding R-410A pressure (°F/psig)			
			35/107.9	40/118.9	45/130.7	50/143.3
CTM18A5*A	600	85/72	43.1	38.6	33.4	27.9
		80/67	35.0	30.3	25.2	19.6
		75/62	27.5	22.8	17.8	11.9
		70/57	20.8	16.1	11.0	8.5
CTM24A5*B	800	85/72	56.0	50.0	43.3	35.9
		80/67	45.5	39.5	32.6	25.2
		75/62	36.0	29.8	23.0	15.4
		70/57	27.3	21.0	14.8	11.4
CTM24B5*B	800	85/72	56.0	50.0	43.3	35.9
		80/67	45.5	39.5	32.6	25.2
		75/62	36.0	29.8	23.0	15.4
		70/57	27.3	21.0	14.8	11.4
CTM30B5*C	1000	85/72	66.1	60.1	52.9	44.6
		80/67	54.6	48.2	40.2	31.9
		75/62	43.9	36.9	29.1	19.0
		70/57	33.8	26.6	19.0	14.8
CTM30C5*C	1000	85/72	66.1	60.1	52.9	44.6
		80/67	54.6	48.2	40.2	31.9
		75/62	43.9	36.9	29.1	19.0
		70/57	33.8	26.6	19.0	14.8
CTM36B5*D	1200	85/72	86.0	77.6	68.0	57.1
		80/67	70.6	61.7	52.0	40.7
		75/62	56.4	47.2	37.2	24.7
		70/57	43.1	33.8	23.9	18.6
CTM36C5*D	1200	85/72	86.0	77.6	68.0	57.1
		80/67	70.6	61.7	52.0	40.7
		75/62	56.4	47.2	37.2	24.7
		70/57	43.1	33.8	23.9	18.6
CTM42C5*E	1400	85/72	93.5	84.6	74.6	62.9
		80/67	77.1	67.8	57.4	45.4
		75/62	62.0	52.2	41.5	27.3
		70/57	47.8	37.8	27.1	21.3
CTM48C5*F	1600	85/72	95.4	86.1	75.5	63.0
		80/67	78.5	68.7	57.7	45.0
		75/62	62.9	44.6	41.5	27.7
		70/57	48.4	38.1	27.5	21.0
CTM48D5*F	1600	85/72	95.4	86.1	75.5	63.0
		80/67	78.5	68.7	57.7	45.0
		75/62	62.9	44.6	41.5	27.7
		70/57	48.4	38.1	27.5	21.0
CTM60C5*G	1800	85/72	115.6	104.2	91.0	76.2
		80/67	94.9	82.8	67.4	54.3
		75/62	75.6	63.1	49.4	33.6
		70/57	57.9	45.1	32.1	24.8
CTM60D5*G	1800	85/72	115.6	104.2	91.0	76.2
		80/67	94.9	82.8	67.4	54.3
		75/62	75.6	63.1	49.4	33.6
		70/57	57.9	45.1	32.1	24.8

**Table 8: Cooling capacity - CTM coil (coil only)**

Model	Rated CFM	Entering air dry bulb/wet bulb (°F)	MBH at evaporation temperature and corresponding R-410A pressure (°F/psig)			
			35/107.9	40/118.9	45/130.7	50/143.3
CTM60C5*H	1800	85/72	113.0	102.6	90.1	75.7
		80/67	93.2	82.1	68.8	54.3
		75/62	74.7	62.9	49.4	33.4
		70/57	57.5	45.1	32.2	25.1
CTM60D5*H	1800	85/72	113.0	102.6	90.1	75.7
		80/67	93.2	82.1	68.8	54.3
		75/62	74.7	62.9	49.4	33.4
		70/57	57.5	45.1	32.2	25.1
CTM60D5*j	1800	85/72	111.3	100.0	87.1	72.3
		80/67	91.5	79.6	66.3	51.3
		75/62	73.1	60.9	46.9	32.6
		70/57	56.1	43.0	32.5	25.0

ⓘ **Note:** The table shows coil only data. Refer to the condensing unit or heat pump *Technical Guide* for the total cooling capacity and sensible capacity.

## Cooling capacity: CTU coils

**Table 9: Cooling capacity - CTU coil (coil only)**

Model	Rated CFM	Entering air dry bulb/wet bulb (°F)	MBH at evaporation temperature and corresponding R-410A pressure (°F/psig)			
			35/107.9	40/118.9	45/130.7	50/143.3
CTU18A5*A	600	85/72	43.2	38.4	32.9	26.9
		80/67	34.8	29.9	24.4	18.9
		75/62	27.2	22.4	17.3	11.7
		70/57	20.6	15.8	10.7	8.1
CTU24A5*B	800	85/72	54.8	49.2	43.0	35.8
		80/67	44.7	39.0	32.3	25.2
		75/62	35.4	29.5	23.0	15.5
		70/57	27.0	20.9	14.2	10.9
CTU30B5*C	1000	85/72	62.3	56.9	49.8	42.3
		80/67	51.9	45.7	38.4	30.5
		75/62	41.7	34.6	27.9	18.4
		70/57	32.1	25.3	18.0	13.9
CTU36B5*D	1200	85/72	80.2	72.1	62.8	52.0
		80/67	65.5	57.2	47.4	36.5
		75/62	52.0	43.5	33.4	22.2
		70/57	39.9	30.9	22.1	16.8
CTU42C5*E	1400	85/72	78.3	72.1	64.7	56.0
		80/67	65.7	59.0	50.9	41.4
		75/62	53.8	46.4	37.8	26.4
		70/57	42.5	34.0	26.0	20.3
CTU48C5*F	1600	85/72	95.6	87.2	77.7	66.3
		80/67	79.5	70.6	60.5	48.4
		75/62	64.5	54.9	44.2	29.6
		70/57	50.2	40.1	29.4	22.9
CTU60C5*G	1600	85/72	102.4	91.9	79.8	66.3
		80/67	83.7	72.6	60.3	47.3
		75/62	66.4	54.9	43.1	29.0
		70/57	50.5	39.3	27.5	20.7
CTU60D5*G	1800	85/72	109.1	98.2	85.3	71.0
		80/67	89.0	77.6	64.7	50.6
		75/62	71.1	58.9	46.2	30.4
		70/57	54.1	42.2	29.8	22.5
CTU60D5*H	1800	85/72	107.0	97.1	85.4	72.2
		80/67	88.2	77.8	65.0	51.9
		75/62	70.9	59.4	47.1	31.8
		70/57	54.5	43.1	30.6	23.4

① **Note:** The table shows coil only data. Refer to the condensing unit or heat pump *Technical Guide* for the total cooling capacity and sensible capacity.

# Application factors

**Table 10: Application factors - rated CFM versus actual CFM - CTF, CTM, and CTU coils**

Percentage of rated airflow (CFM)	80%	90%	100%	110%	120%
Capacity factor	0.96	0.98	1	1.02	1.03

**Note:** Do not exceed the minimum and maximum CFM limits shown in [Airflow data: CTF coils](#), [Airflow data: CTM coils](#), and [Airflow data: CTU coils](#).

## Application limitations

Adhere to the following:

- These units must be installed in accordance with all national and local safety codes.
- Airflow must be within the minimum and maximum limits approved for electric heat, indoor coils, and outdoor units.

## Static pressure versus airflow based on wet coil: CTF coils

**Table 11: Static pressure versus airflow based on wet coil - CTF coil - upflow A type**

Model	Airflow	Static
<b>Upflow A type</b>		
CTF18A5A	525	0.13
	600	0.15
	675	0.18
CTF18B5A	525	0.11
	600	0.12
	675	0.14
CTF24A5*B	700	0.21
	800	0.25
	900	0.29
CTF24B5*B	700	0.15
	800	0.17
	900	0.19
CTF30B5*C	875	0.16
	1000	0.19
	1125	0.21
CTF30C5*C	875	0.16
	1000	0.18
	1125	0.20
CTF30A5*D	875	0.31
	1000	0.37
	1125	0.44
CTF36B5*D	1050	0.26
	1200	0.31
	1350	0.37
CTF36C5*D	1050	0.23
	1200	0.27
	1350	0.32

**Table 11: Static pressure versus airflow based on wet coil - CTF coil - upflow A type**

<b>Model</b>	<b>Airflow</b>	<b>Static</b>
<b>Upflow A type</b>		
CTF36B5*E	1050	0.28
	1200	0.33
	1350	0.39
CTF42C5*E	1225	0.27
	1400	0.31
	1575	0.36
CTF48C5*F	1400	0.28
	1600	0.33
	1800	0.39
CTF48D5*F	1400	0.24
	1600	0.27
	1800	0.32
CTF60C5*G	1550	0.25
	1800	0.32
	2050	0.40
CTF60D5*G	1550	0.23
	1800	0.28
	2050	0.33
CTF60C5*H	1550	0.24
	1800	0.30
	2050	0.37
CTF60D5*H	1550	0.25
	1800	0.31
	2050	0.39
CTF60D5*j	1550	0.36
	1800	0.46
	2050	0.58

# Static pressure versus airflow based on wet coil: CTM coils

**Table 12: Static pressure versus airflow based on wet coil - CTM coil - upflow A type**

Model	Airflow	Static
<b>Upflow A type</b>		
CTM18A5*A	525	0.15
	600	0.17
	675	0.20
CTM24A5*B	700	0.22
	800	0.27
	900	0.31
CTM24B5*B	700	0.17
	800	0.20
	900	0.23
CTM30B5*C	875	0.22
	1000	0.25
	1125	0.30
CTM30C5*C	875	0.18
	1000	0.21
	1125	0.24
CTM36B5*D	1050	0.36
	1200	0.45
	1350	0.54
CTM36C5*D	1050	0.26
	1200	0.31
	1350	0.37
CTM42C5*E	1225	0.32
	1400	0.39
	1575	0.46
CTM48C5*F	1400	0.34
	1600	0.41
	1800	0.49
CTM48D5*F	1400	0.25
	1600	0.29
	1800	0.34
CTM60C5*G	1550	0.24
	1800	0.33
	2050	0.43
CTM60D5*G	1550	0.29
	1800	0.35
	2050	0.42
CTM60C5*H	1550	0.22
	1800	0.31
	2050	0.41
CTM60D5*H	1550	0.29
	1800	0.37
	2050	0.48
CTM60D5*J	1550	0.37
	1800	0.50
	2050	0.64

## Static pressure versus airflow based on wet coil: CTU coils

**Table 13: Static pressure versus airflow based on wet coil - CTU coil - upflow A type**

Model	Airflow	Static
<b>Upflow A type</b>		
CTU18A5*A	700	0.13
	900	0.15
	675	0.18
CTU24A5*B	650	0.21
	800	0.25
	900	0.29
CTU30B5*C	875	0.16
	1000	0.19
	1125	0.21
CTU36B5*D	1050	0.26
	1200	0.31
	1350	0.37
CTU42C5*E	1225	0.27
	1400	0.31
	1575	0.36
CTU48C5*F	1400	0.28
	1600	0.33
	1800	0.39
CTU60C5*G	1550	0.25
	1800	0.32
	2050	0.40
CTU60D5*G	1550	0.23
	1800	0.28
	2050	0.33
CTU60D5*H	1550	0.36
	1800	0.46
	2050	0.58

# Coil technical data: CTF coils

**Table 14: Coil technical data - CTF coil**

Model	Application	Refrig. conn. types	Face area (sq. ft.)	Rows deep	Fins per in.	Coil size	Tube geometry	Tube diameter (in.)	Fin type	Shipping weight (lb)	Installed weight (lb)
CTF18A5AAS1	Cooling /Heat pump	Sweat	3.3	2	18	(2) 14 x 17	1 x 0.675	3/8	Lanced	32	31
CTF18A5AAN1	Cooling /Heat pump	Sweat	3.3	2	18	(2) 14 x 17	1 x 0.675	3/8	Lanced	32	31
CTF18B5AAS1	Cooling /Heat pump	Sweat	3.3	2	18	(2) 14 x 17	1 x 0.675	3/8	Lanced	33	32
CTF18B5AAN1	Cooling /Heat pump	Sweat	3.3	2	18	(2) 14 x 17	1 x 0.675	3/8	Lanced	33	32
CTF24A5ABS1	Cooling /Heat pump	Sweat	3.8	2	18	(2) 16 x 17	1 x 0.675	3/8	Lanced	34	33
CTF24A5ABN1	Cooling /Heat pump	Sweat	3.8	2	18	(2) 16 x 17	1 x 0.675	3/8	Lanced	34	33
CTF24B5ABS1	Cooling /Heat pump	Sweat	3.8	2	18	(2) 16 x 17	1 x 0.675	3/8	Lanced	37	36
CTF24B5ABN1	Cooling /Heat pump	Sweat	3.8	2	18	(2) 16 x 17	1 x 0.675	3/8	Lanced	37	36
CTF30B5ACS1	Cooling /Heat pump	Sweat	4.7	2	18	(2) 20 x 17	1 x 0.675	3/8	Lanced	42	41
CTF30B5ACN1	Cooling /Heat pump	Sweat	4.7	2	18	(2) 20 x 17	1 x 0.675	3/8	Lanced	42	41
CTF30C5ACS1	Cooling /Heat pump	Sweat	4.7	2	18	(2) 20 x 17	1 x 0.675	3/8	Lanced	48	46
CTF30C5ACN1	Cooling /Heat pump	Sweat	4.7	2	18	(2) 20 x 17	1 x 0.675	3/8	Lanced	48	46
CTF30A5ADS1	Cooling /Heat pump	Sweat	4.7	3	14	(2) 20 x 17	1 x 0.675	3/8	Lanced	42	41
CTF30A5ADN1	Cooling /Heat pump	Sweat	4.7	3	14	(2) 20 x 17	1 x 0.675	3/8	Lanced	42	41
CTF36B5ADS1	Cooling /Heat pump	Sweat	4.7	3	14	(2) 20 x 17	1 x 0.675	3/8	Lanced	49	48
CTF36B5ADN1	Cooling /Heat pump	Sweat	4.7	3	14	(2) 20 x 17	1 x 0.675	3/8	Lanced	49	48
CTF36B5CDS1	Cooling /Heat pump	Sweat	4.7	3	14	(2) 20 x 17	1 x 0.675	3/8	Lanced	49	48
CTF36B5CDN1	Cooling /Heat pump	Sweat	4.7	3	14	(2) 20 x 17	1 x 0.675	3/8	Lanced	49	48
CTF36C5CDS1	Cooling /Heat pump	Sweat	4.7	3	14	(2) 20 x 17	1 x 0.675	3/8	Lanced	49	47
CTF36C5CDN1	Cooling /Heat pump	Sweat	4.7	3	14	(2) 20 x 17	1 x 0.675	3/8	Lanced	49	47
CTF36B5CES1	Cooling /Heat pump	Sweat	5.2	3	14	(2) 22 x 17	1 x 0.675	3/8	Lanced	51	50
CTF36B5CEN1	Cooling /Heat pump	Sweat	5.2	3	14	(2) 22 x 17	1 x 0.675	3/8	Lanced	51	50
CTF42C5AES1	Cooling /Heat pump	Sweat	5.2	3	14	(2) 22 x 17	1 x 0.675	3/8	Lanced	54	52
CTF42C5CES1	Cooling /Heat pump	Sweat	5.2	3	14	(2) 22 x 17	1 x 0.675	3/8	Lanced	54	52
CTF48C5AFS1	Cooling /Heat pump	Sweat	5.7	3	12	(2) 24 x 17	1 x 0.675	3/8	Lanced	57	55
CTF48C5CFS1	Cooling /Heat pump	Sweat	5.7	3	12	(2) 24 x 17	1 x 0.675	3/8	Lanced	57	55
CTF48D5CFS1	Cooling /Heat pump	Sweat	5.7	3	12	(2) 24 x 17	1 x 0.675	3/8	Lanced	60	58
CTF60C5CGS1	Cooling /Heat pump	Sweat	6.6	3	12	(2) 28 x 17	1 x 0.675	3/8	Lanced	66	64
CTF60D5CGS1	Cooling /Heat pump	Sweat	6.6	3	12	(2) 28 x 17	1 x 0.675	3/8	Lanced	68	66
CTF60C5CHS1	Cooling /Heat pump	Sweat	7.6	3	12	(2) 32 x 17	1 x 0.675	3/8	Lanced	72	70



**Table 14: Coil technical data - CTF coil**

Model	Application	Refrig. conn. types	Face area (sq. ft.)	Rows deep	Fins per in.	Coil size	Tube geometry	Tube diameter (in.)	Fin type	Shipping weight (lb)	Installed weight (lb)
CTF60D5CHS1	Cooling /Heat pump	Sweat	7.6	3	12	(2) 32 x 17	1 x 0.675	3/8	Lanced	76	74
CTF60D5CJS1	Cooling /Heat pump	Sweat	6.6	4	12	(2) 28 x 17	1 x 0.675	3/8	Lanced	75	73

## Coil technical data: CTM coils

**Table 15: Coil technical data - CTM coil**

Model	Application	Refrig. conn. types	Face area (sq. ft.)	Rows deep	Fins per in.	Coil size	Tube geometry	Tube diameter (in.)	Fin type	Shipping weight (lb)	Installed weight (lb)
CTM18A5AAS1	Cooling /Heat pump	Sweat	3.3	2	18	(2) 14 x 17	1 x 0.675	3/8	Lanced	39	38
CTM18A5AAN1	Cooling /Heat pump	Sweat	3.3	2	18	(2) 14 x 17	1 x 0.675	3/8	Lanced	39	38
CTM24A5ABS1	Cooling /Heat pump	Sweat	3.8	2	18	(2) 16 x 17	1 x 0.675	3/8	Lanced	41	40
CTM24A5ABN1	Cooling /Heat pump	Sweat	3.8	2	18	(2) 16 x 17	1 x 0.675	3/8	Lanced	41	40
CTM24B5ABS1	Cooling /Heat pump	Sweat	3.8	2	18	(2) 16 x 17	1 x 0.675	3/8	Lanced	39	38
CTM24B5ABN1	Cooling /Heat pump	Sweat	3.8	2	18	(2) 16 x 17	1 x 0.675	3/8	Lanced	39	38
CTM30B5ACS1	Cooling /Heat pump	Sweat	4.7	2	18	(2) 20 x 17	1 x 0.675	3/8	Lanced	45	44
CTM30B5ACN1	Cooling /Heat pump	Sweat	4.7	2	18	(2) 20 x 17	1 x 0.675	3/8	Lanced	45	44
CTM30C5ACS1	Cooling /Heat pump	Sweat	4.7	2	18	(2) 20 x 17	1 x 0.675	3/8	Lanced	54	53
CTM30C5ACN1	Cooling /Heat pump	Sweat	4.7	2	18	(2) 20 x 17	1 x 0.675	3/8	Lanced	54	53
CTM36B5ADS1	Cooling /Heat pump	Sweat	4.7	3	14	(2) 20 x 17	1 x 0.675	3/8	Lanced	52	50
CTM36B5ADN1	Cooling /Heat pump	Sweat	4.7	3	14	(2) 20 x 17	1 x 0.675	3/8	Lanced	52	50
CTM36B5CDS1	Cooling /Heat pump	Sweat	4.7	3	14	(2) 20 x 17	1 x 0.675	3/8	Lanced	52	50
CTM36B5CDN1	Cooling /Heat pump	Sweat	4.7	3	14	(2) 20 x 17	1 x 0.675	3/8	Lanced	52	50
CTM36C5CDS1	Cooling /Heat pump	Sweat	4.7	3	14	(2) 20 x 17	1 x 0.675	3/8	Lanced	60	58
CTM36C5CDN1	Cooling /Heat pump	Sweat	4.7	3	14	(2) 20 x 17	1 x 0.675	3/8	Lanced	60	58
CTM42C5AES1	Cooling /Heat pump	Sweat	5.2	3	14	(2) 22 x 17	1 x 0.675	3/8	Lanced	64	62
CTM42C5CES1	Cooling /Heat pump	Sweat	5.2	3	14	(2) 22 x 17	1 x 0.675	3/8	Lanced	64	62
CTM48C5CFS1	Cooling /Heat pump	Sweat	5.7	3	12	(2) 24 x 17	1 x 0.675	3/8	Lanced	75	73
CTM48D5CFS1	Cooling /Heat pump	Sweat	5.7	3	12	(2) 24 x 17	1 x 0.675	3/8	Lanced	82	80
CTM60C5CGS1	Cooling /Heat pump	Sweat	6.6	3	12	(2) 28 x 17	1 x 0.675	3/8	Lanced	70	68
CTM60D5CGS1	Cooling /Heat pump	Sweat	6.6	3	12	(2) 28 x 17	1 x 0.675	3/8	Lanced	74	72
CTM60C5CHS1	Cooling /Heat pump	Sweat	7.6	3	12	(2) 32 x 17	1 x 0.675	3/8	Lanced	80	78
CTM60D5CHS1	Cooling /Heat pump	Sweat	7.6	3	12	(2) 32 x 17	1 x 0.675	3/8	Lanced	86	84
CTM60D5CJS1	Cooling /Heat pump	Sweat	6.6	4	12	(2) 28 x 17	1 x 0.675	3/8	Lanced	85	83

## Coil technical data: CTU coils

**Table 16: Coil technical data - CTU coil**

Model	Application	Refrig. conn. types	Face area (sq. ft.)	Rows deep	Fins per in.	Coil size	Tube geometry	Tube diameter (in.)	Fin type	Shipping weight (lb)	Installed weight (lb)
CTU18A5XAS1	Cooling /Heat pump	Sweat	3.3	2	18	(2) 14 x 17	1 x 0.675	3/8	Lanced	17	16
CTU24A5XBS1	Cooling /Heat pump	Sweat	3.8	2	18	(2) 16 x 17	1 x 0.675	3/8	Lanced	19	18
CTU30B5XCS1	Cooling /Heat pump	Sweat	4.7	2	18	(2) 20 x 17	1 x 0.675	3/8	Lanced	21	20
CTU36B5XDS1	Cooling /Heat pump	Sweat	4.7	3	14	(2) 20 x 17	1 x 0.675	3/8	Lanced	27	26
CTU42C5XES1	Cooling /Heat pump	Sweat	5.2	3	14	(2) 22 x 17	1 x 0.675	3/8	Lanced	30	28
CTU48C5XFS1	Cooling /Heat pump	Sweat	5.7	3	12	(2) 24 x 17	1 x 0.675	3/8	Lanced	33	31
CTU60C5XGS1	Cooling /Heat pump	Sweat	6.6	3	12	(2) 28 x 17	1 x 0.675	3/8	Lanced	36	34
CTU60D5XGS1	Cooling /Heat pump	Sweat	6.6	3	12	(2) 28 x 17	1 x 0.675	3/8	Lanced	40	38
CTU60D5XHS1	Cooling /Heat pump	Sweat	7.6	3	12	(2) 32 x 17	1 x 0.675	3/8	Lanced	45	43

## Airflow data: CTF coils

**Table 17: CTF airflow data (CFM) - upflow**

Model	CFM								
	400	600	800	1000	1200	1400	1600	1800	2000
	Coil pressure drop (in. W.C.)								
CTF18A5A	0.05	0.11	0.18	—	—	—	—	—	—
CTF18B5*A	0.04	0.07	0.13	—	—	—	—	—	—
CTF24A5*B	0.05	0.11	0.19	0.28	—	—	—	—	—
CTF24B5*B	0.03	0.07	0.11	0.16	—	—	—	—	—
CTF30B5*C	0.04	0.07	0.11	0.15	0.21	—	—	—	—
CTF30C5*C	0.03	0.06	0.08	0.12	0.16	—	—	—	—
CTF30A5*D	0.06	0.12	0.20	0.29	—	—	—	—	—
CTF36B5*D	0.03	0.06	0.11	0.16	0.23	0.30	—	—	—
CTF36C5*D	0.02	0.05	0.10	0.14	0.20	0.25	—	—	—
CTF36B5*E	0.03	0.07	0.11	0.16	0.23	—	—	—	—
CTF42C5*E	0.02	0.04	0.08	0.11	0.16	0.21	0.27	—	—
CTF48C5*F	0.01	0.04	0.07	0.10	0.14	0.19	0.24	0.30	—
CTF48D5*F	0.02	0.04	0.06	0.08	0.11	0.15	0.19	0.23	—
CTF60C5*G	0.01	0.03	0.05	0.08	0.12	0.16	0.22	0.27	0.33
CTF60D5*G	0.01	0.02	0.04	0.06	0.09	0.12	0.15	0.19	0.23
CTF60C5*H	0.02	0.04	0.06	0.09	0.12	0.16	0.21	0.26	0.31
CTF60D5*H	0.01	0.03	0.05	0.06	0.09	0.11	0.15	0.18	0.22
CTF60D5*J	0.01	0.03	0.06	0.08	0.12	0.18	0.22	0.26	0.31

① **Note:**

- Airflow data is for dry coil conditions only, tested without filters.
- For optimal performance, external static pressures of 0.2 in. W.C. to 0.6 in. W.C. are recommended. Applications above 0.6 in. W.C. are not recommended.

**Table 18: CTF airflow data (CFM) - downflow**

Model	CFM								
	400	600	800	1000	1200	1400	1600	1800	2000
	Coil pressure drop (in. W.C.)								
CTF18A5A	0.07	0.16	0.26	—	—	—	—	—	—
CTF18B5*A	0.05	0.11	0.19	—	—	—	—	—	—
CTF24A5*B	0.06	0.13	0.23	0.34	—	—	—	—	—
CTF24B5*B	0.05	0.09	0.16	0.24	—	—	—	—	—
CTF30B5*C	0.05	0.09	0.15	0.21	0.29	—	—	—	—
CTF30C5*C	0.04	0.07	0.11	0.16	0.22	—	—	—	—
CTF30A5*D	0.08	0.18	0.29	0.43	—	—	—	—	—
CTF36B5*D	0.04	0.09	0.16	0.24	0.33	0.45	—	—	—
CTF36C5*D	0.03	0.07	0.11	0.16	0.23	0.31	—	—	—
CTF36B5*E	0.05	0.10	0.16	0.24	0.34	—	—	—	—
CTF42C5*E	0.03	0.06	0.11	0.15	0.22	0.28	0.38	—	—
CTF48C5*F	0.02	0.05	0.09	0.13	0.19	0.27	0.34	0.43	—
CTF48D5*F	0.02	0.05	0.08	0.11	0.15	0.20	0.26	0.33	—
CTF60C5*G	0.02	0.04	0.08	0.12	0.17	0.23	0.30	0.38	0.47
CTF60D5*G	0.01	0.03	0.06	0.09	0.13	0.17	0.23	0.28	0.34
CTF60C5*H	0.03	0.05	0.09	0.13	0.18	0.24	0.32	0.40	0.49
CTF60D5*H	0.02	0.04	0.06	0.09	0.13	0.16	0.21	0.27	0.33
CTF60D5*J	0.02	0.04	0.07	0.11	0.16	0.22	0.28	0.34	0.42

① **Note:**

- Airflow data is for dry coil conditions only, tested without filters.
- For optimal performance, external static pressures of 0.2 in. W.C. to 0.6 in. W.C. are recommended. Applications above 0.6 in. W.C. are not recommended.

## Airflow data: CTM coils

**Table 19: CTM Airflow data (CFM) - horizontal left and upflow**

Model	CFM								
	400	600	800	1000	1200	1400	1600	1800	2000
	Coil pressure drop (in. W.C.)								
CTM18A5*A	0.07	0.14	0.21	—	—	—	—	—	—
CTM24A5*B	0.06	0.13	0.21	0.30	—	—	—	—	—
CTM24B5*B	0.05	0.09	0.14	0.20	—	—	—	—	—
CTM30B5*C	0.04	0.08	0.13	0.19	0.26	—	—	—	—
CTM30C5*C	0.04	0.07	0.11	0.14	0.20	—	—	—	—
CTM36B5*D	0.05	0.11	0.18	0.25	0.36	0.49	—	—	—
CTM36C5*D	0.04	0.07	0.12	0.16	0.23	0.31	—	—	—
CTM42C5*E	0.03	0.07	0.11	0.15	0.22	0.28	0.37	—	—
CTM48C5*F	0.03	0.06	0.09	0.13	0.19	0.25	0.32	0.40	—
CTM48D5*F	0.02	0.04	0.06	0.09	0.12	0.16	0.21	0.25	—
CTM60C5*G	0.02	0.05	0.08	0.12	0.17	0.23	0.30	0.37	0.45
CTM60D5*G	0.02	0.04	0.06	0.09	0.13	0.16	0.21	0.26	0.32
CTM60C5*H	0.02	0.05	0.08	0.12	0.17	0.23	0.30	0.37	0.46
CTM60D5*H	0.02	0.04	0.06	0.08	0.12	0.16	0.20	0.25	0.30
CTM60D5*J	0.03	0.06	0.09	0.13	0.17	0.22	0.29	0.35	0.43

**Note:**

- Airflow data is for dry coil conditions only, tested without filters.
- For optimal performance, external static pressures of 0.2 in. W.C. to 0.6 in. W.C. are recommended. Applications above 0.6 in. W.C. are not recommended.

**Table 20: CTM airflow data (CFM) - horizontal right and downflow**

Model	CFM								
	400	600	800	1000	1200	1400	1600	1800	2000
	Coil pressure drop (in. W.C.)								
CTM18A5*A	0.07	0.14	0.23	—	—	—	—	—	—
CTM24A5*B	0.06	0.13	0.21	0.31	—	—	—	—	—
CTM24B5*B	0.05	0.09	0.15	0.20	—	—	—	—	—
CTM30B5*C	0.04	0.08	0.13	0.18	0.25	—	—	—	—
CTM30C5*C	0.04	0.07	0.11	0.15	0.20	—	—	—	—
CTM36B5*D	0.05	0.11	0.17	0.25	0.35	0.48	—	—	—
CTM36C5*D	0.04	0.07	0.12	0.16	0.23	0.30	—	—	—
CTM42C5*E	0.03	0.07	0.11	0.15	0.21	0.28	0.37	—	—
CTM48C5*F	0.03	0.06	0.10	0.14	0.20	0.26	0.34	0.43	—
CTM48D5*F	0.00	0.04	0.06	0.09	0.13	0.17	0.22	0.27	—
CTM60C5*G	0.03	0.06	0.09	0.13	0.19	0.25	0.33	0.41	0.50
CTM60D5*G	0.02	0.04	0.07	0.09	0.13	0.18	0.23	0.28	0.34
CTM60C5*H	0.03	0.06	0.09	0.13	0.19	0.25	0.33	0.40	0.49
CTM60D5*H	0.02	0.04	0.06	0.09	0.13	0.17	0.22	0.27	0.33
CTM60D5*J	0.03	0.06	0.10	0.14	0.19	0.25	0.33	0.40	0.49

**Note:**

- Airflow data is for dry coil conditions only, tested without filters.
- For optimal performance, external static pressures of 0.2 in. W.C. to 0.6 in. W.C. are recommended. Applications above 0.6 in. W.C. are not recommended.

## Airflow data: CTU coils

**Table 21: CTU airflow data (CFM) - upflow**

Model	CFM								
	400	600	800	1000	1200	1400	1600	1800	2000
	Coil pressure drop (in. W.C.)								
CTU18A5*A	0.05	0.11	0.18	—	—	—	—	—	—
CTU24A5*B	0.05	0.11	0.19	0.28	—	—	—	—	—
CTU30B5*C	0.04	0.07	0.11	0.15	0.21	—	—	—	—
CTU36B5*D	0.03	0.06	0.11	0.16	0.23	0.30	—	—	—
CTU42C5*E	0.02	0.04	0.08	0.11	0.16	0.21	0.27	—	—
CTU48C5*F	0.01	0.04	0.07	0.10	0.14	0.19	0.24	0.30	—
CTU60C5*G	0.01	0.03	0.05	0.08	0.12	0.16	0.22	0.27	0.33
CTU60D5*G	0.01	0.02	0.04	0.06	0.09	0.12	0.15	0.19	0.23
CTU60D5*H	0.01	0.03	0.06	0.08	0.12	0.18	0.22	0.26	0.31

① **Note:**

- Airflow data is for dry coil conditions only, tested without filters.
- For optimal performance, external static pressures of 0.2 in. W.C. to 0.6 in. W.C. are recommended. Applications above 0.6 in. W.C. are not recommended.

**Table 22: CTU airflow data (CFM) - downflow**

Model	CFM								
	400	600	800	1000	1200	1400	1600	1800	2000
	Coil pressure drop (in. W.C.)								
CTU18A5*A	0.07	0.16	0.26	—	—	—	—	—	—
CTU24A5*B	0.06	0.13	0.23	0.34	—	—	—	—	—
CTU30B5*C	0.05	0.09	0.15	0.21	0.29	—	—	—	—
CTU36B5*D	0.04	0.09	0.16	0.24	0.33	0.45	—	—	—
CTU42C5*E	0.03	0.06	0.11	0.15	0.22	0.28	0.38	—	—
CTU48C5*F	0.02	0.05	0.09	0.13	0.19	0.27	0.34	0.43	—
CTU60C5*G	0.02	0.04	0.08	0.12	0.17	0.23	0.30	0.38	0.47
CTU60D5*G	0.01	0.03	0.06	0.09	0.13	0.17	0.23	0.28	0.34
CTU60D5*H	0.02	0.04	0.07	0.11	0.16	0.22	0.28	0.34	0.42

① **Note:**

- Airflow data is for dry coil conditions only, tested without filters.
- For optimal performance, external static pressures of 0.2 in. W.C. to 0.6 in. W.C. are recommended. Applications above 0.6 in. W.C. are not recommended.

**Third-Party Trademarks Notice:** For information about third-party trademarks, refer to the relevant company websites.

---

Subject to change without notice. Published in U.S.A. Copyright © 2024 by Johnson Controls. All rights reserved.