

Tabular Data Sheet

LX Series Split-System Heat Pumps

14.3 SEER2 – R-454B – Single-Phase – 2 nominal ton to 5 nominal ton
Models: XH424 to 60

Physical and electrical data

Unit model	XH424E2S11	XH436E2S11	XH448E2S11	XH460E2S11
Unit supply voltage	208-230 V, 1 Ph, 60 Hz			
Normal voltage range (V) ¹	187 to 252			
Minimum circuit ampacity (A)	14.7	20.1	30.5	37.4
Maximum overcurrent device (A) ²	25	35	50	60
Minimum overcurrent device (A) ³	15	25	35	40
Compressor	Type	Two-stage scroll	Two-stage scroll	Two-stage scroll
	Rated load (A)	11.2	15.5	23.3
	Locked rotor (A)	62.0	76.0	141.0
Crankcase heater	No	No	No	No
Factory external discharge muffler	Yes	Yes	Yes	Yes
Hard start kit required with TXV ⁴	No	No	No	No
Fan diameter (in.)	22	22	24	24
Fan motor	Type	PSC	PSC	PSC
	Rated HP	0.125	0.125	0.250
	Rated load (A)	0.70	0.70	1.30
	Nominal RPM	1075	1075	850
	Nominal CFM	3000	3200	4100
Coil	Face area (sq ft)	14.6	17.9	23.8
	Rows deep	1	1	1
	Fins per inch	22	22	22
Liquid refrigerant piping outdoor (field-installed)	3/8	3/8	3/8	3/8
Vapor refrigerant piping outdoor (field-installed) ⁵	3/4	3/4	7/8	1 1/8‡
Unit charge (lb - oz) ⁶	5 - 1	5	8 - 6	10 - 5
Charge (oz/ft)	0.57	0.57	0.60	0.67
Operating weight (lb)	143	165	221	239

1. Rated in accordance with AHRI Standard 110-2012, utilization range A.

2. Dual element fuses or HACR circuit breaker. Maximum allowable overcurrent protection.

3. Dual element fuses or HACR circuit breaker. Minimum recommended overcurrent protection.

4. Refer to the *Hard Start Kit Accessory Installation Manual* for the hard start kit part number for each model. The hard start kit is a field-installed accessory.

5. For applications with non-standard vapor line sizes, refer to the *Applications and Accessories* section in the *Technical Guide*.

6. The unit charge is correct for the outdoor unit, smallest matched indoor unit, and 15 ft of refrigerant tubing. For tubing lengths other than 15 ft, add or subtract the amount of refrigerant, using the difference in actual refrigerant piping length (not the equivalent length) multiplied by the per foot value.

‡ The adapter fitting must be field-installed for the required 1 1/8 in. refrigerant piping.

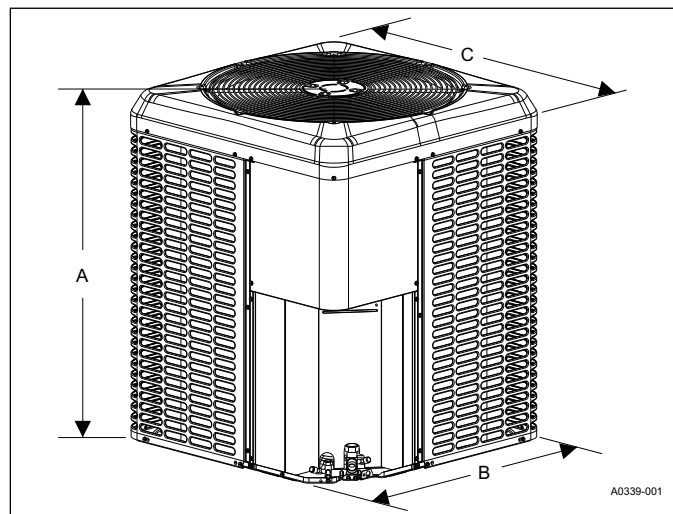

Dimensions

Unit model	Dimensions (in.)			Refrigerant connection service valve size (in.)	
	A	B	C	Liquid	Vapor
XH424E2S11	30	29 1/4	29 1/4	3/8	3/4
XH436E2S11	36 1/4	29 1/4	29 1/4		7/8
XH448E2S11	39 1/2	35 1/4	31 3/4		7/8
XH460E2S11	39 1/2	35 1/4	31 3/4		7/8‡

Notes:

All dimensions are in inches and are subject to change without notice.

The overall height is from the bottom of the base pan to the top of the fan guard.

The overall length and width include screw heads.

‡ The adapter fitting must be field-installed for the required 1 1/8 in. of refrigerant piping.

System charge for various matched systems

Charge adjustment	Upflow or horizontal left				Downflow or horizontal right ¹			
	24	36	48	60	24	36	48	60
Outdoor unit	24	36	48	60	24	36	48	60
Required indoor metering device ^{2,3}	5A1	5C1	5C1	5C1	5A1	5C1	5C1	5C1
Indoor unit ^{4,5,6}	Additional charge (oz)							
CT(F,M,U)30°C	0	—	—	—	1	—	—	—
CT(F,M,U)30°D	—	0	—	—	—	-28	—	—
CT(F,M,U)36°D	—	0	—	—	—	-28	—	—
CT(F,M,U)48°F	—	4	—	—	—	-28	—	—
CT(F,M,U)60°G	—	—	2	—	—	—	20	—
CT(F,M,U)60°H	—	—	0	0	—	—	17	-40
CT(F,M,U)60°J	—	—	—	0	—	—	—	-11
JHE24°C	0	—	—	—	1	—	—	—
JHE30°D	—	0	—	—	—	-28	—	—
JHE36°D	—	0	—	—	—	-28	—	—
JHE42°F	—	4	—	—	—	8	—	—
JHE48°G	—	—	2	—	—	—	20	—
JHE60°H	—	—	0	0	—	—	17	-40
JHE60°J	—	—	—	0	—	—	—	-11
JHC24°C	0	—	—	—	1	—	—	—
JHC36°D	—	0	—	—	—	-28	—	—
JHC42°F	—	4	—	—	—	8	—	—
JHC48°G	—	—	2	—	—	—	20	—
JHC60°H	—	—	0	0	—	—	17	-40
JHC60°J	—	—	—	0	—	—	—	-11

Note: Some of the combinations shown in this table require advanced main air circulating fan indoor product. For approved coil-only matches, refer to the System capacity tables in the *Technical Guide*.

1. A negative number indicates that you remove that charge.
2. For applications that require a TXV, use S1-1TVM*** series kit.
3. Use a TXV kit with these indoor units to obtain system performance.
4. Systems matched with furnaces or air handlers not equipped with blower-off delays may require blower time delay.
5. Do not use CTF or CTU coils in horizontal applications.
6. The charge adders shown above do not indicate that coils are rated for every application. Refer to the performance data tables in the *Technical Guide* for actual performance for specified system matches. Obtain certified system ratings from www.ahridirectory.org.

Charging

1. Check the factory unit charge listed on the unit nameplate to verify the refrigerant charge for the outdoor unit, the smallest matched indoor unit, and the 15 ft of interconnecting refrigeration piping.
2. Verify the indoor metering device and additional charge required for the specific matched indoor unit in the system using the table above.
3. Add additional charge for the amount of interconnecting refrigeration piping greater than 15 ft at the rate specified in the *Physical and electrical data* table.
4. For installations requiring additional charge, weigh in refrigerant for the specific matching indoor unit and actual refrigeration piping length.
5. After weighing in the charge adders for the matched indoor unit and refrigeration piping, verify the system operation against the temperatures and pressures in the charging chart for the outdoor unit. Locate the charging charts on the outdoor unit and also in the *Service Data Application Guide* on www.simplygettingthejobdone.com. Follow the subcool or superheat charging procedure in the *Installation Manual* according to the type of indoor metering device in the system, and allow 10 min after each charge adjustment for the system operation to stabilize. Record the charge adjustment made to match the charging chart.
6. Permanently stamp the unit nameplate with the total system charge defined as follows: total system charge = base charge (as shipped) + charge adder for matched indoor unit + charge adder for actual refrigeration piping length + charge adjustments to match the charging chart.