

# INSTALLATION MANUAL

**SINGLE PACKAGE  
AIR CONDITIONER/GAS HEAT  
MODELS: PCG6 SERIES  
2 TONS TO 5 TONS - 208/230 V - 1 PHASE**



## LIST OF SECTIONS

GENERAL INFORMATION . . . . .	1	AIRFLOW PERFORMANCE . . . . .	11
SAFETY . . . . .	1	OPERATION . . . . .	15
MODEL NUMBER NOMENCLATURE . . . . .	2	TYPICAL WIRING DIAGRAMS . . . . .	25
INSTALLATION . . . . .	2	START UP SHEET . . . . .	27

## LIST OF FIGURES

Component Location . . . . .	3	Control Board . . . . .	20
Center of Gravity Location . . . . .	5	Gas Valve . . . . .	21
Unit Dimensions . . . . .	5	Reading Gas Pressure . . . . .	22
Bottom Duct Dimensions (in.) . . . . .	6	Measuring External Static Pressure . . . . .	23
Rear Duct Dimensions (in.) . . . . .	6	R-410A Quick Reference Guide . . . . .	23
Typical Field Control Wiring Diagram for Gas Heat - AC Models . . . . .	7	Connection Wiring Diagram . . . . .	25
Typical Field Power Wiring Diagram . . . . .	7	Ladder Wiring Diagram . . . . .	26
Flue Vent Outlet Air Hood . . . . .	10		

## LIST OF TABLES

Unit Limitations - PCG6 . . . . .	3	Natural Gas Application Data - PCG6 . . . . .	10
Application Limitations . . . . .	3	Propane (LP) Gas Application Data - PCG6 . . . . .	11
Weights and Dimensions . . . . .	4	Airflow Performance - Side Duct Application . . . . .	11
Unit Dimensions . . . . .	5	Additional Static Resistance . . . . .	15
Unit Clearances . . . . .	5	Default Blower Speeds . . . . .	16
Electrical Data - PCG6 . . . . .	7	Delay Profile Descriptions . . . . .	19
Physical Data . . . . .	8	Inlet Gas Pressure Range . . . . .	21
Natural Gas Pipe Sizing Chart . . . . .	9	Nominal Manifold Pressure . . . . .	21
Propane (LP) Gas Pipe Sizing Chart . . . . .	9	Gas Rate (ft <sup>3</sup> /h) . . . . .	22
High Altitude Gas Orifice Sizing . . . . .	10		

## SECTION I: GENERAL INFORMATION

These are electric cooling/gas heating units designed for outdoor installation. Only gas piping, electric power, and duct connections are required for installation.

The gas-fired heaters have spark ignition.

The refrigerant system is fully charged with R-410A refrigerant. The system is tested and factory sealed.

## SECTION II: SAFETY

 This is a safety alert symbol. When you see this symbol on labels or in manuals, be alert to the potential for personal injury.

Understand and pay particular attention to the signal words **DANGER**, **WARNING**, or **CAUTION**.

**DANGER** indicates an **imminently** hazardous situation, which, if not avoided, **will result in death or serious injury**.

**WARNING** indicates a **potentially** hazardous situation, which, if not avoided, **could result in death or serious injury**.

**CAUTION** indicates a potentially hazardous situation, which, if not avoided **may result in minor or moderate injury**. It is also used to alert against unsafe practices and hazards involving only property damage.

## ⚠ WARNING

*Improper installation may create a condition where the operation of the product could cause personal injury or property damage. Improper installation, adjustment, alteration, service or maintenance can cause injury or property damage. **Failure to carefully read and follow all instructions in this manual can result in furnace malfunction, death, personal injury and/or property damage.** Only a qualified contractor, installer or service agency should install this product.*

## ⚠ CAUTION

*This product must be installed in strict compliance with the installation instructions and any applicable local, state, and national codes including, but not limited to building, electrical, and mechanical codes.*

**⚠ WARNING**

Before performing service or maintenance operations on unit, turn off main power switch to unit. Electrical shock could cause personal injury. Improper installation, adjustment, alteration, service or maintenance can cause injury or property damage. Refer to this manual for information. For additional assistance, consult a qualified installer, service agency or the gas supplier.

**⚠ CAUTION**

This system uses R-410A refrigerant which operates at higher pressures than R-22. No other refrigerant may be used in this system. Gage sets, hoses, refrigerant containers and recovery systems must be designed to handle R-410A. If you are unsure, consult the equipment manufacturer. Failure to use R-410A compatible servicing equipment may result in property damage or injury.

**⚠ WARNING**

If the information in this manual is not followed exactly, a fire or explosion may result causing property damage, personal injury or loss of life.

Do not store or use gasoline or other flammable vapors and liquids in the vicinity of this or any other appliance.

**WHAT TO DO IF YOU SMELL GAS:**

1. Do not try to light any appliance.
2. Do not touch any electrical switch; do not use any phone in your building.
3. Immediately call your gas supplier from a neighbor's phone. Follow the gas supplier's instructions.
4. If you cannot reach your gas supplier, call the fire department.

Installation and service must be performed by a qualified installer, service agency or the gas supplier.

Due to system pressure, moving parts, and electrical components, installation and servicing of air conditioning equipment can be hazardous. Only qualified, trained service personnel must install, repair, or service this equipment. Untrained personnel can perform the basic maintenance functions of cleaning coils and filters and replacing filters.

Observe all precautions in the literature, labels, and tags accompanying the equipment whenever working on air conditioning equipment. Ensure to follow all other applicable safety precautions and codes including ANSI Z223.1 or CSA-B149.1- latest edition.

Wear safety glasses and work gloves. Use quenching cloth and have a fire extinguisher available during brazing operations.

**SECTION III: MODEL NUMBER NOMENCLATURE**

PCG	6	A	24	050	2	X	4	A
1	2	3	4	5	6	7	8	9
<b>1. Model Family</b> PCG - packaged A/C with gas heat PHG - packaged heat pump with gas heat PCE - packaged A/C with electric heat PHE - packaged heat pump with electric heat <b>2. Nominal Cooling Efficiency</b> 4 = 14 SEER, 6 = 16 SEER <b>3. Cabinet Size</b> A = small 35.75 x 51.25, B = large 45.75 x 51.25 <b>4. Nominal Air Conditioning Cooling Capacity BTU/h x 1000</b> 24 = 24,000 BTU/h, 30 = 30,000 BTU/h <b>Example:</b> PCG6A240502X4A is a packaged A/C with gas heat, 16 SEER, small cabinet, 2 ton, two-stage heat, 50,000 BTU/h gas heat, 208/230 V, single-phase, Low NOx model, fourth generation, original release.					<b>5. Gas Heating Input BTU/h x 1000</b> 050 = 50,000 BTU/h input, blank = electric heat <b>6. Voltage-Phase-Frequency</b> 2 = 208/230-1-60, 3 = 208/230-3-60, 4 = 460-3-60 <b>7. NOx Approval</b> X = Low NOx, blank = not Low NOx <b>8. Generation Level</b> 1 = first generation, 2 = second generation <b>9. Revision Level</b> A = original release, B = second release			

**SECTION IV: INSTALLATION****INSTALLATION SAFETY INFORMATION**

Read these instructions before continuing this appliance installation. This is an outdoor combination heating and cooling unit. The installer must ensure that these instructions are made available to the consumer with instructions to retain them for future reference.

- Refer to the unit rating plate for the approved type of gas for this product.
- Install this unit only in a location and position as specified on Page 4 of these instructions.
- Never test for gas leaks with an open flame. Use commercially available soap solution made specifically for the detection of leaks when checking all connections, as specified on Page 10 of these instructions.

- Always install the unit to operate within the unit's intended temperature rise range with the duct system and within the allowable external static pressure range, as specified on the unit name/rating plate and in Table 7 of these instructions.
- This equipment is not to be used for temporary heating of buildings or structures under construction.

**⚠ WARNING****FIRE OR EXPLOSION HAZARD**

Failure to follow the safety warning exactly could result in serious injury, death or property damage.

Never test for gas leaks with an open flame. Use a commercially available soap solution made specifically for the detection of leaks to check all connections. A fire or explosion may result causing property damage, personal injury or loss of life.

**LIMITATIONS**

These units must be installed in accordance with the following:

**In U.S.A:**

- National Electrical Code, ANSI/NFPA No. 70 - Latest Edition
- National Fuel Gas Code, ANSI Z223.1 - Latest Edition
- Gas-Fired Central Furnace Standard, ANSI Z21.47a. - Latest Edition
- Local building codes
- Local gas utility requirements

**In Canada:**

- Canadian Electrical Code, CSA C22.1
- Installation Codes, CSA - B149.1
- Local plumbing and waste water codes
- Other applicable local codes

See the unit application data in this document.

After installation, gas fired units must be adjusted to obtain a temperature rise within the range specified on the unit rating plate.

If it is necessary to add components to a unit to meet local codes, installation is done at the dealer's and/or customer's expense.

The size of the unit for proposed installation must be based on heat loss/heat gain calculation made according to the methods of Air Conditioning Contractors of America (ACCA).

This furnace is not to be used for temporary heating of buildings or structures under construction.

**Table 1:** Unit Limitations - PCG6

Model	Unit Voltage	Unit Limitations		
		Applied Voltage		Outdoor DB Temperature
		Minimum	Maximum	Maximum (°F)
All Models	208/230-1-60	187	252	125

**Table 2:** Application Limitations

Packaged Equipment Series	Air Temperature at Outdoor Coil (°F)		Air Temperature at Indoor Coil (°F)	
	Minimum	Maximum	Minimum	Maximum
	DB Cool	DB Cool	WB Cool	WB Cool
16 SEER AC	55	125	57	72

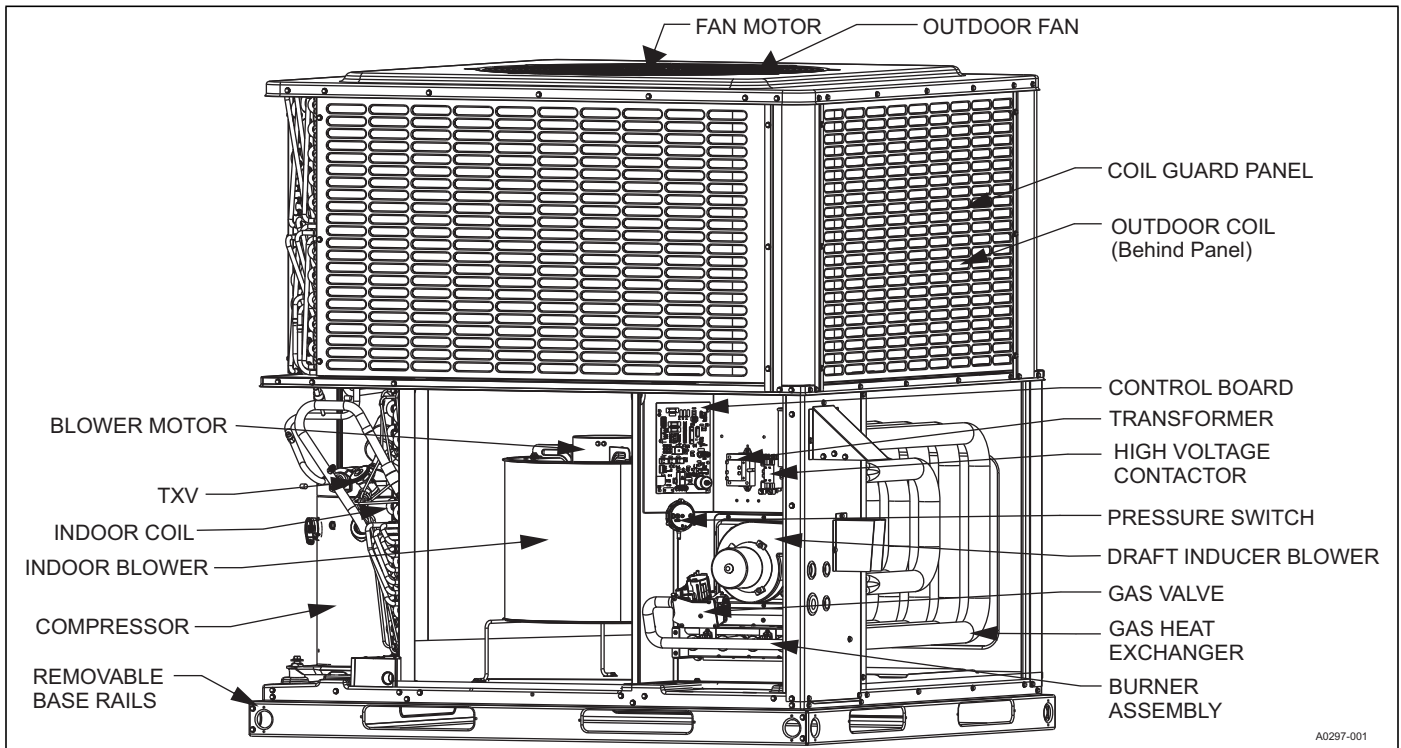

**Figure 1:** Component Location

## LOCATION

**⚠ WARNING**

*Excessive exposure of this unit to contaminated combustion air may result in equipment damage or personal injury. Typical contaminants include: permanent wave solution, chlorinated waxes and cleaners, chlorine based swimming pool chemicals, water softening chemicals, carbon tetrachloride, Halogen type refrigerants, cleaning solvents (e.g. perchloroethylene), printing inks, paint removers, varnishes, hydrochloric acid, cements and glues, anti-static fabric softeners for clothes dryers, masonry acid washing materials.*

Use the following guidelines to select a suitable location for these units:

**⚠ WARNING**

*Do not attach supply and return duct work to the bottom of the unit base pan as the drain pan could be compromised.*

- Unit is designed for **outdoor installation** only.
- Outdoor coils must have an unlimited supply of air. Where a choice of location is possible, position the unit on either north or east side of building.
- Suitable for mounting on roof curb.
- For ground level installation, use a level pad or slab. The thickness and size of the pad or slab used must meet local codes and requirements of unit weight. Do not tie the slab to the building foundation.
- Roof structures must be able to support the weight of the unit and its options/accessories. Unit must be installed on a solid, level roof curb or appropriate angle iron frame.
- Maintain level tolerance to 1/8 in. across the entire width and length of unit.

## CLEARANCES

**⚠ WARNING**

*Do not permit overhanging structures or shrubs to obstruct outdoor air discharge outlet, combustion air inlet or vent outlets.*

All units require particular clearances for proper operation and service. Installer must make provisions for adequate combustion and ventilation air in accordance with section 5.3 of Air for Combustion and Ventilation of the National Fuel Gas Code, ANSI Z223.1 – Latest Edition (in U.S.A.), or Sections 7.2, 7.3, or 7.4 of Gas Installation Codes, CSA-B149.1 (in Canada) - Latest Edition, and/or applicable provisions of the local building codes. See Table 5 for clearances required for combustible construction, servicing, and proper unit operation.

## RIGGING AND HANDLING

**⚠ CAUTION**

*If a unit is to be installed on a roof curb other than a Ducted Systems roof curb, gasket or sealant must be applied to all surfaces that come in contact with the unit underside.*

**⚠ CAUTION**

*All panels must be secured in place when the unit is lifted. The outdoor coils should be protected from rigging cable damage with plywood or other suitable material.*

Exercise care when moving the unit. Do not remove any packaging until the unit is near the place of installation. Rig the unit by attaching chain or cable slings to the lifting holes provided in the base rails. **ENSURE** to use the spreader bars across the top of the unit if the length of the spreader bars exceeds the largest dimension across the unit.

**⚠ CAUTION**

*Before lifting, make sure the unit weight is distributed equally on the rigging cables so it will lift evenly.*

Units can be moved or lifted with a forklift. Slotted openings in the base rails are provided for this purpose.

**Table 3:** Weights and Dimensions

Model	Weight (lb)		Center of Gravity		4-Point Load Location (lb)			
	Shipping	Operating	X	Y	A	B	C	D
PCG6A24050	372	367	28	15	120	95	81	71
PCG6A24075	382	377	28	15	124	96	81	76
PCG6A36075	466	461	28	15	161	113	96	91
PCG6A36100	473	468	28	15	163	114	101	90
PCG6B48065	520	515	28	15	189	116	93	117
PCG6B48100	528	523	28	15	169	139	115	100
PCG6B48125	533	528	28	15	164	145	124	95
PCG6B60065	537	532	29	15	174	142	124	92
PCG6B60100	541	536	28	15	177	140	117	102
PCG6B60125	548	543	27	15	151	167	141	84

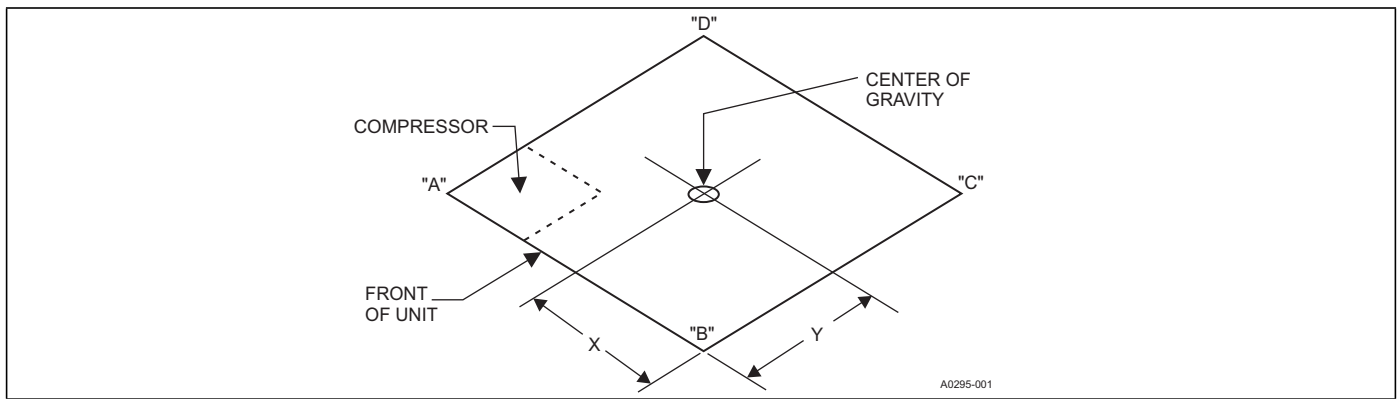

Figure 2: Center of Gravity Location

Table 4: Unit Dimensions

Model	Dimensions (in.)		
	A	B	C
PCG6A24	51 1/4	35 3/4	45
PCG6A36	51 1/4	35 3/4	47
PCG6B48	51 1/4	45 3/4	47
PCG6B60	51 1/4	45 3/4	50

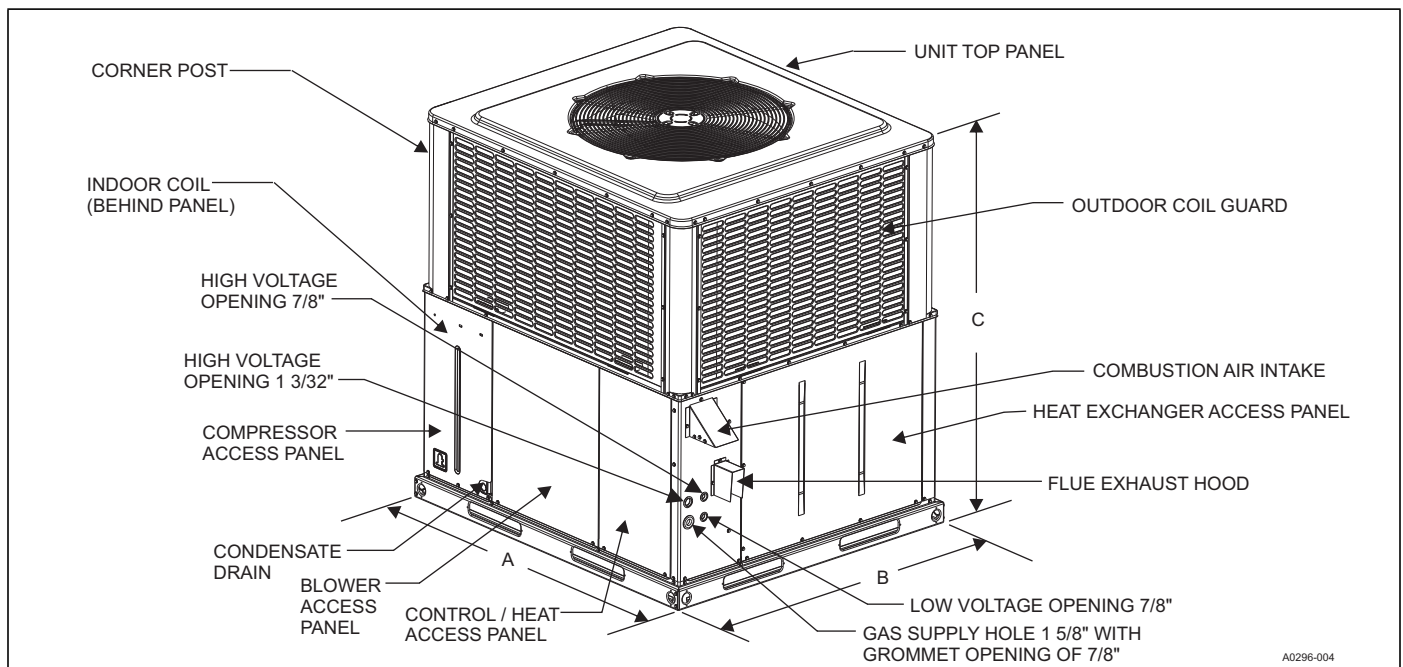

Figure 3: Unit Dimensions

Table 5: Unit Clearances<sup>1,2</sup>

Direction	Distance (in.)	Direction	Distance (in.)
Top <sup>3</sup>	36	Power Entry (Right Side)	36
Side Opposite Ducts	36	Left Side	24
Duct Panel	0	Bottom <sup>4</sup>	1

1. A 1 in. clearance must be provided between any combustible material and the supply air duct work.
2. The products of combustion must not be allowed to accumulate within a confined space and recirculate.
3. Units must be installed outdoors. Overhanging structures or shrubs must not obstruct outdoor air discharge outlet.
4. Units can be installed on combustible materials made from wood or class A, B, or C roof covering materials if factory base rails are left in place as shipped.

DUCTWORK

**NOTICE**

*All units are shipped in the horizontal supply/return configuration. It is important to reduce the possibility of any air leakage through the bottom duct covers (resulting from cut, torn, or rolled gasket) due to improper handling or shipping processes. To ensure a good tight seal, it is recommended that silicone caulk and/or foil tape be applied along the cover edges.*

These units are adaptable to downflow use. To convert to downflow, use the following steps:

1. Remove the duct covers found in the bottom return and supply air duct openings.
2. Install the duct covers removed in step one to the rear supply and return air duct openings.
3. Seal duct covers with silicone caulk.

Duct work must be designed and sized according to the methods of the Air Conditioning Contractors of America (ACCA) as set forth in their Manual D.

Use a closed return duct system. This does not preclude use of economizers or ventilation air intake. It is best practice to use flexible joints in the supply and return duct work to minimize the transmission of vibration and noise.

**NOTICE**

*Be sure to note supply and return openings.*

See Figures 4 and 5 for information concerning rear and bottom supply and return air duct openings.

FILTERS

Proper filter size is very important. Filter size, type, and pressure drop must always be considered during duct system design.

Single phase units are shipped without a filter or filter racks. It is the responsibility of the installer to secure a filter in the return air ductwork or install a Filter/Frame Kit.

Always use filters and keep filters clean. When filters become dirt laden:

- Insufficient air is delivered by the blower
- The unit efficiency is decreased
- Operating costs are increased
- Wear-and-tear is increased on the unit and controls

Check filters monthly. This is especially important because the unit can be used for both heating and cooling.

CONDENSATE DRAIN

A condensate trap must be installed in the condensate drain. The plumbing must conform to local codes.

**CAUTION**

*Hand tighten only.*

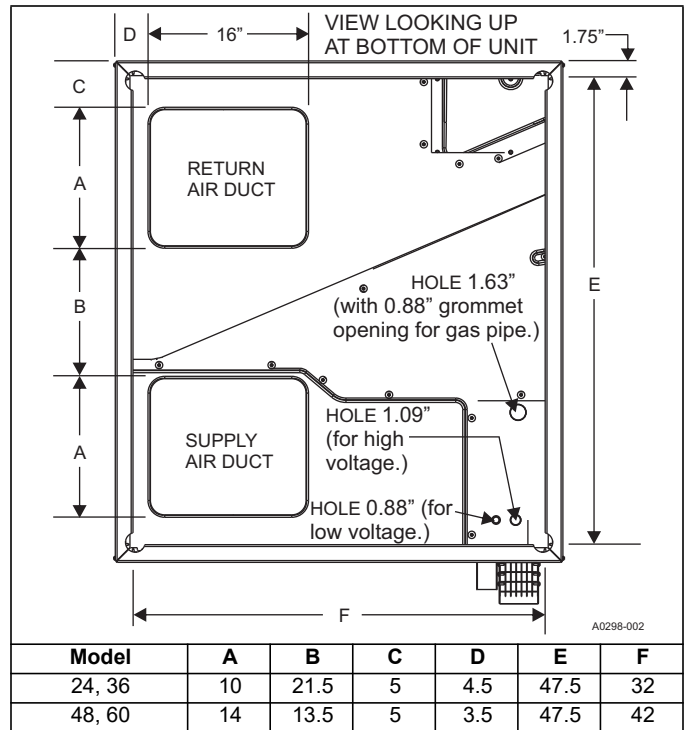

Figure 4: Bottom Duct Dimensions (in.)

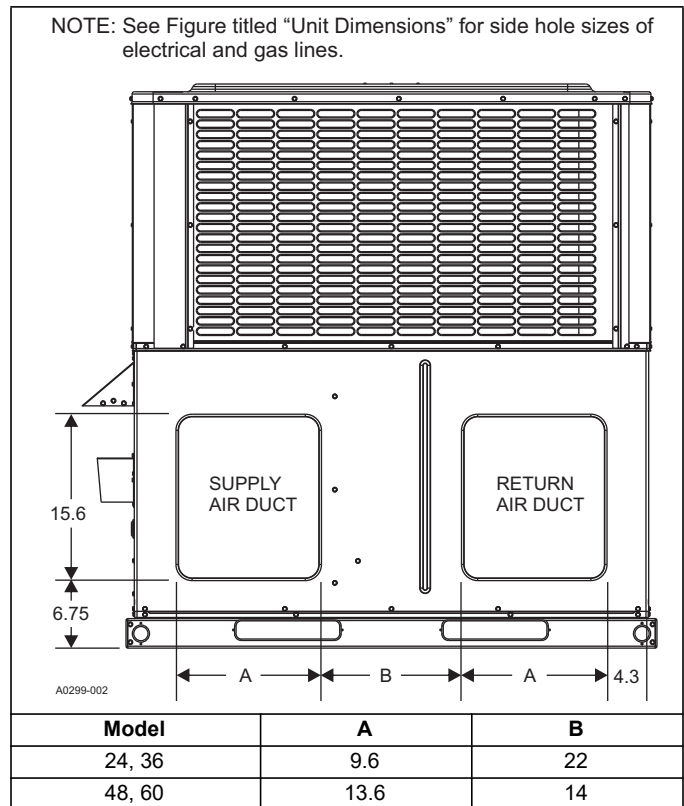

Figure 5: Rear Duct Dimensions (in.)

**SERVICE ACCESS**

Access to all serviceable components is provided at the following locations:

- Coil guards
- Unit top panel
- Corner posts
- Blower access panel
- Control access panel
- Indoor coil access panel
- Compressor access panel
- Heat exchanger access panel

See Figure 3 for the location of these access locations and see Table 5 for minimum clearances.

**⚠ CAUTION**

*This system uses R-410A refrigerant which operates at higher pressures than some alternative refrigerants. Only R-410A refrigerant may be used in this system. Gauge sets, hoses, refrigerant containers and recovery systems must be designed to handle R-410A. If unsure, the equipment manufacturer should be consulted. Failure to use R-410A compatible servicing equipment may result in property damage or injury.*

**⚠ WARNING**

*Wear safety glasses and gloves when handling refrigerants. Failure to follow this warning can cause serious personal injury.*

See Figure 13 for the R-410A Quick Reference Guide.

**THERMOSTAT**

Locate the room thermostat on an inside wall approximately 60 in. above the floor where it is not subject to drafts, sun exposure, or heat from electrical fixtures or appliances. Use sealant behind the thermostat to prevent air infiltration. Follow manufacturer instructions enclosed with the thermostat for general installation procedures. Use color coded insulated wires (minimum 18 AWG) to connect the thermostat to the unit. See Figure 6.

This unit contains a multistage cooling compressor. Use a two heat/two cool (2H/2C) conventional thermostat. If a single stage thermostat is used, the high/low gas heat input staging can be controlled by a built-in staging function on the unit control board. Do not use power stealing thermostats.

**POWER AND CONTROL WIRING**

Field wiring to the unit must conform to provisions of the current NEC ANSI/NFPA No. 70 or CEC and/or local ordinances. The unit must be electrically grounded in accordance with local codes or, in their absence, with the NEC/CEC. The correct voltage must be maintained at the compressor terminals during starting and running conditions. See Table 1 for voltage tolerances.

**Table 6:** Electrical Data - PCG6

Model	Voltage	Compressor			Outdoor Fan Motor	Indoor Blower Motor	MCA <sup>1</sup> (A)	Max Fuse <sup>2</sup> / Breaker <sup>3</sup> Size (A)
		RLA	LRA	MCC	FLA	FLA		
24050	208/230-1-60	10.2	55.2	15.9	0.8	2.6	16.1	25
24075	208/230-1-60	10.2	55.2	15.9	0.8	3.8	17.3	25
36075	208/230-1-60	14.2	78.1	22.1	1.7	3.8	23.2	35
36100	208/230-1-60	14.2	78.1	22.1	1.7	5.4	24.8	35
48065, 48100, 48125	208/230-1-60	17.1	109.0	26.6	1.7	5.4	28.4	45
60065, 60100, 60125	208/230-1-60	23.5	118.0	36.6	1.7	7.0	38.0	60

1. Minimum Circuit Ampacity.  
 2. Maximum Over Current Protection per standard UL 1995.  
 3. Fuse or HACR circuit breaker is field installed.

The wiring entering the cabinet must be provided with mechanical strain relief. A fused disconnect switch must be field provided for the unit. If any of the wire supplied with the unit must be replaced, replacement wire must be of the type shown on the wiring diagram.

Electrical service must be sized properly to carry the load. Each unit must be wired with a separate branch circuit fed directly from the main distribution panel and properly fused.

See Figures 6 and 7 for typical field wiring and for the appropriate unit wiring diagram of the control circuit and power wiring information.

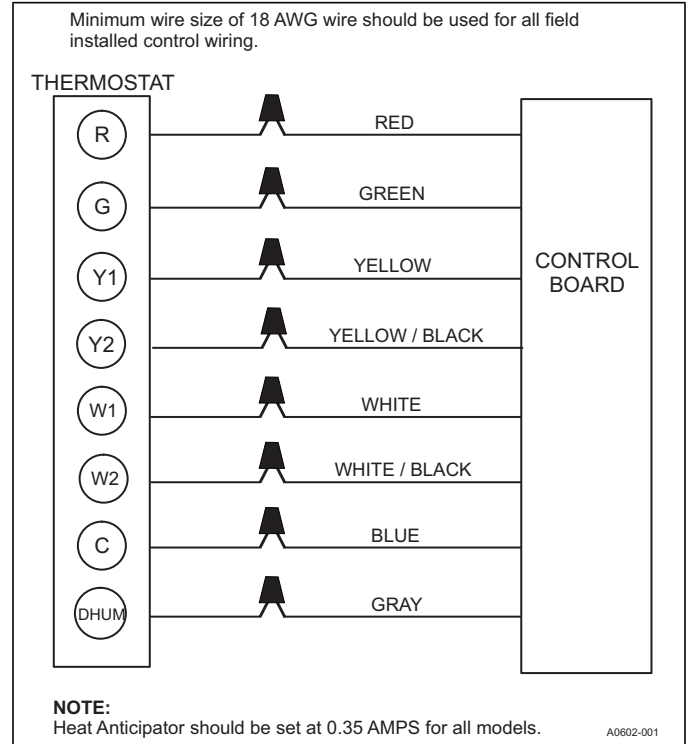

**Figure 6:** Typical Field Control Wiring Diagram for Gas Heat - AC Models

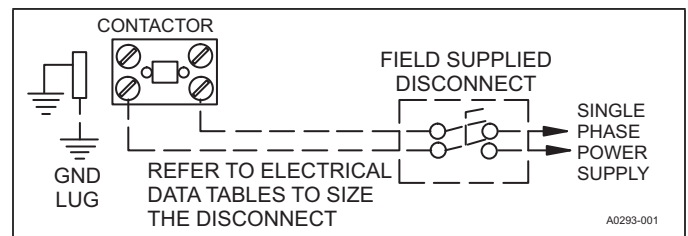

**Figure 7:** Typical Field Power Wiring Diagram

Table 7: Physical Data

MODELS:	PCG6A24		PCG6A36		PCG6B48			PCG6B60		
NOMINAL TONNAGE:	2.0		3.0		4.0			5.0		
<b>Refrigerant Information</b>										
Refrigerant type	R-410A		R-410A		R-410A			R-410A		
Refrigerant charge (lb-oz)	4-3		7-2		7-14			10-2		
<b>AHRI Gas Heat Performance</b>										
Heating model	50	75	75	100	65	100	125	65	100	125
Heat input - High Fire (KBTU)	50	75	75	100	65	100	125	65	100	125
Heat output - High Fire (KBTU)	40	60	60	80	52	80	101	52	80	101
Heat input - Low Fire (KBTU)	33	49	49	65	43	65	82	43	65	82
Heat output - Low Fire (KBTU)	26	39	39	53	34	53	66	34	53	66
AFUE %	81.0	81.0	81.0	81.0	81.0	81.0	81.0	81.0	81.0	81.0
No. of burners	2	3	3	4	2	3	4	2	3	4
No. of stages	2	2	2	2	2	2	2	2	2	2
Temperature rise range - High Fire (°F)	40-70		40-70		40-70			40-70		
Temperature rise range - Low Fire (°F)	20-50		20-50	25-55	25-55			25-55		
Maximum static pressure W.C.	0.5		0.5		0.5			0.5		
Maximum outlet air temperature (°F)	180		180		180			180		
Gas piping connection (in.)	1/2		1/2		1/2			1/2		
<b>Dimensions (in.)</b>										
Length	51 1/4		51 1/4		51 1/4			51 1/4		
Width	35 3/4		35 3/4		45 3/4			45 3/4		
Height	44		47		47			50		
<b>Compressor</b>										
Type	Scroll		Scroll		Scroll			Scroll		
Stages	2		2		2			2		
<b>Outdoor Coil Data</b>										
Face area (ft <sup>2</sup> )	12.3		15.3		17.5			21.1		
Rows	1		2		2			2		
Fins per inch	22		22		22			22		
Tube diameter (mm)	7		7		7			7		
Circuitry type	Straight		Interlaced		Interlaced			Interlaced		
<b>Indoor Coil Data</b>										
Face area (ft <sup>2</sup> )	4.6		4.6		6.2			6.2		
Rows	2		3		3			4		
Fins per inch	16		16		16			16		
Tube diameter (in.)	3/8		3/8		3/8			3/8		
Circuitry type	Interlaced		Interlaced		Interlaced			Interlaced		
Refrigerant control	TXV		TXV		TXV			TXV		
<b>Outdoor Fan Data</b>										
Fan diameter (in.)	24		24		26			26		
Type	Prop		Prop		Prop			Prop		
Drive type	Direct		Direct		Direct			Direct		
No. of speeds	1		1		1			1		
Motor HP each	1/8		1/3		1/3			1/3		
RPM	790		850		850			850		
Nominal total CFM	2400		2400		3200			3200		
<b>Direct Drive Indoor Blower Data</b>										
Blower size (in.)	11 x 8		11 x 10		11 x 10			11 x 10		
Type	Centrifugal		Centrifugal		Centrifugal			Centrifugal		
Motor HP each	1/3	1/2	1/2	3/4	3/4			1		
RPM	1400 Maximum		1400 Maximum		1400 Maximum			1400 Maximum		
Frame size	48		48		48			48		
<b>Filters</b>										
Filter size	A		A		B			B		
Quantity - size	Field-supplied external filters must be sized so as not to exceed 300 fpm air velocity through disposable filters. For internal filter use, a filter rack kit is available. Consult the instructions supplied with the kit for replacement filter sizes. Filter sizes: A = 20 in. x 20 in., B = 20 in. x 30 in.									



## COMPRESSORS

**⚠ CAUTION**

*This system uses R-410A refrigerant which operates at higher pressures than R-22. No other refrigerant may be used in this system.*

The compressor used in this product is specifically designed to operate with R-410A refrigerant and cannot be interchanged. Compressors used in PCG6 models contain two internal bypass ports that enable the compressor to operate at 67% part load capacity.

The compressor uses polyolester (POE) oil, Mobil 3MA POE. This oil is extremely hygroscopic, meaning it absorbs water readily. POE oil can absorb 15 times as much water as other oils designed for HCFC and CFC refrigerants. If refrigerant circuit is opened, take all necessary precautions to avoid exposure of the oil to the atmosphere.

**⚠ CAUTION**

*Do not leave the system open to the atmosphere. Unit damage could occur due to moisture being absorbed by the **POE oil** in the system. This type of oil is highly susceptible to moisture absorption.*

POE compressor lubricants are known to cause long-term damage to some synthetic roofing materials.

**⚠ CAUTION**

*Exposure, even if immediately cleaned up, may cause embrittlement (leading to cracking) to occur in one year or more. When performing any service that may risk exposure of compressor oil to the roof, take precautions to protect roofing.*

Procedures that risk oil leakage include, but are not limited to, replacing compressor, repairing refrigerant leaks, and replacing refrigerant components such as filter drier, pressure switch, metering device, or coil.

**⚠ CAUTION**

*Do not loosen compressor mounting bolts.*

Units are shipped with compressor mountings that are factory-adjusted and ready for operation.

## GAS HEAT

These two stage gas-fired heat sections have direct spark ignition.

## GAS PIPING

Proper sizing of gas piping depends on the cubic feet per hour of gas flow required, specific gravity of the gas, and the length of run. National Fuel Gas Code Z223.1 or CSA B149.1 must be followed in all cases unless superseded by local codes or gas company requirements. See Tables 8 and 9.

The BTU content of the gas may differ with locality. Check the value with the local gas utility.

**NOTICE**

*There may be a local gas utility requirement specifying a minimum diameter for gas piping. All units require a 1/2 in. pipe connection at the gas valve.*

## GAS CONNECTION

The gas supply line must be routed through the 1-5/8 in. hole located on the right side of the unit. See Figure 3 for the location. The unit is supplied with a rubber grommet that fits in this hole and is used to seal around the gas pipe. **THIS GROMMET MUST BE INSTALLED TO PREVENT LEAKAGE OF AIR AND WATER INTO THE HEATING/CONTROLS COMPARTMENT.**

**Gas piping requirements:**

- Install a drip leg and a ground joint union in the gas piping.
- Install a manual shut-off valve outside of the unit if required by local codes.

**⚠ CAUTION**

*If flexible stainless steel tubing is allowed by the authority having jurisdiction, wrought iron or steel pipe must be installed at the gas valve and extend a minimum of two (2) inches outside of the unit casing.*

- Use wrought iron or steel pipe for all gas lines. Apply pipe thread sealant sparingly to male threads only.

**Table 8:** Natural Gas Pipe Sizing Chart<sup>1</sup>

Length (ft)	Nominal Inches Iron Pipe Size			
	1/2 in.	3/4 in.	1 in.	1 1/4 in.
10	132	278	520	1,050
20	92	190	350	730
30	73	152	285	590
40	63	130	245	500
50	56	115	215	440
60	50	105	195	400
70	46	96	180	370
80	43	90	170	350
90	40	84	160	320
100	38	79	150	305

1. Maximum capacity of pipe in cubic feet of gas per hour (based upon a pressure drop of 0.3 in. W.C. and 0.6 specific gravity gas).

**Table 9:** Propane (LP) Gas Pipe Sizing Chart<sup>1</sup>

Length (ft)	Nominal Inches Iron Pipe Size			
	1/2 in.	3/4 in.	1 in.	1 1/4 in.
10	275	567	1071	2,205
20	189	393	732	1496
30	152	315	590	1212
40	129	267	504	1039
50	114	237	448	913
60	103	217	409	834
70	96	196	378	771
80	89	185	346	724
90	83	173	322	677
100	78	162	307	630

1. Maximum capacity of pipe in thousands of BTU per hour (based upon a pressure drop of 0.5 in. W.C.).

**⚠ WARNING**

*Natural gas may contain some propane. Propane being an excellent solvent, will quickly dissolve white lead or most standard commercial compounds. Therefore, a special pipe thread sealant must be applied when wrought iron or steel pipe is used. Compounds such as RectorSeal No. 5 or equivalent compounds may be used.*

- Clean all piping of dirt and scale by hammering on the outside of the pipe and blowing out the loose dirt and scale. Before initial start-up, ensure that all of the gas lines external to the unit have been purged of air.
- Ensure that the gas supply is a separate line and is installed in accordance with all applicable safety codes. After the gas connections have been completed, open the main shut-off valve admitting normal gas pressure to the gas valve. Check all joints for leaks with soap solution or other material suitable for the purpose. **NEVER USE AN OPEN FLAME** to check for leaks.

## ⚠ WARNING

### **FIRE OR EXPLOSION HAZARD**

Failure to follow the safety warning exactly could result in serious injury, death or property damage.

Never test for gas leaks with an open flame. Use a commercially available soap solution made specifically for the detection of leaks to check all connections. A fire or explosion may result causing property damage, personal injury or loss of life.

- Pressure tests in excess of 1/2 psig (3.48 kPa): During the gas supply piping system pressure test, ensure that the unit and its equipment shutoff valve is disconnected from the gas supply system.
- Pressure tests equal to or less than 1/2 psig (3.48 kPa): During the gas supply piping system pressure test, verify that the unit is isolated from the gas supply piping system by closing its individual manual shut-off valve.

**Table 10:** High Altitude Gas Orifice Sizing

Gas Type	Cabinet Size	Elevation Above Sea Level (ft)								
		0–2000 (Factory)	2001– 3000	3001– 4000	4001– 5000	5001– 6000	6001– 7000	7001– 8000	8001– 9000	9001– 10000
Natural Gas Orifice Sizes	B	36	37	38	38	39	40	41	41	42
	A	42	42	43	43	43	44	44	45	46
LP Gas Orifice Sizes	B	51	51	52	52	52	52	53	53	53
	A	54	54	55	55	55	55	55	56	56

### FLUE VENT AND AIR INTAKE HOOD

The flue vent hood and air intake hoods are shipped loose. These hoods must be installed to ensure proper unit operation. The hoods must be fastened to the outside of the side gas control/electrical compartment with the screws provided. See Figure 8.

## ⚠ WARNING

Flue hood surfaces may be hot.

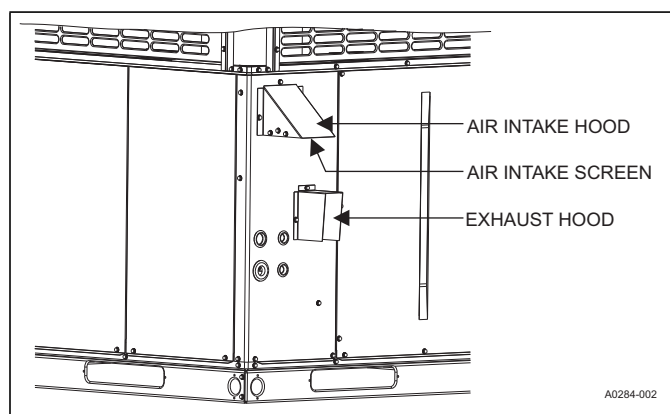

**Figure 8:** Flue Vent Outlet Air Hood

## ⚠ CAUTION

The flue exhaust hood must be properly installed within the recommended clearances. Further communications and action must be given to the home or building owner(s) to eliminate any unauthorized human contact around this area during the heating cycle. Flue hood surfaces and the immediate area reach high temperatures during the heating cycle.

**Table 11:** Natural Gas Application Data - PCG6

Available on Models	Input (MBH) <sup>1</sup> High Fire/Low Fire	Output (MBH) High Fire/Low Fire	Gas Rate <sup>2</sup> ft <sup>3</sup> /h High Fire/Low Fire	Number of Burners	Temperature Rise °F	
					Minimum	Maximum
2 Ton	50/33	40/26	46.5/29.8	2	40	70
4, 5 Ton	65/43	52/34	60.5/40.0	2	40	70
2, 3 Ton	75/49	60/39	69.8/45.6	3	40	70
4, 5 Ton	100/65	80/53	93.0/60.5	3	40	70
3 Ton	100/65	80/53	93.0/60.5	4	40	70
4, 5 Ton	125/82	101/66	116.3/75.3	4	40	70

1. Input rate valid for elevations up to 2,000 ft above sea level. For elevations above 2,000 ft, gas input rate must be reduced by 4% for each 1,000 ft above sea level.

2. Based on 1075 BTU/ft<sup>3</sup>.

3. The airflow must be adequate to obtain a temperature rise within the range shown. Continuous return air temperature should not be below 55°F.

**Table 12:** Propane<sup>1</sup> (LP) Gas Application Data - PCG6

Available on Models	Input (MBH) <sup>2</sup> High Fire/Low Fire	Output (MBH) High Fire/Low Fire	Gas Rate <sup>3</sup> ft <sup>3</sup> /h High Fire/Low Fire	Number of Burners	Temperature Rise °F <sup>4</sup>		Propane Conversion Accessory Kit
					Minimum	Maximum	
2 Ton	50/33	40/26	20.0/12.8	2	40	70	S1-1NP0703
4, 5 Ton	65/43	52/34	26.0/16.8	2	40	70	S1-1NP0704
2, 3 Ton	75/49	60/39	30.0/19.6	3	40	70	S1-1NP0703
4, 5 Ton	100/65	80/53	40.0/26.0	3	40	70	S1-1NP0704
3 Ton	100/65	80/53	40.0/26.0	4	40	70	S1-1NP0703
4, 5 Ton	125/82	101/66	50.0/32.4	4	40	70	S1-1NP0704

1. Propane applications are accomplished by field installation of a Propane Conversion Accessory Kit. For more information, refer to the APPLICATIONS AND ACCESSORIES section in the Technical Guide.

2. Input rate valid for elevations up to 2,000 ft above sea level. For elevations above 2,000 ft, gas input rate must be reduced by 4% for each 1,000 ft above sea level.

3. Based on 2500 BTU/ft<sup>3</sup>.

4. The airflow must be adequate to obtain a temperature rise within the range shown. Continuous return air temperature should not be below 55°F.

## SECTION V: AIRFLOW PERFORMANCE

**Table 13:** Airflow Performance - Side Duct Application

Model	Jumper Position		External Static Pressure (in. W.C.)									
			0.1	0.2	0.3	0.4	0.5	0.6	0.7	0.8	0.9	1.0
			SCFM	SCFM	SCFM	SCFM	SCFM	SCFM	SCFM	SCFM	SCFM	SCFM
PCG6A24050	High Cool	A	900	870	830	800	750	690	660	610	570	530
		B	850	810	770	730	680	630	590	550	500	460
		C	760	730	690	640	580	540	490	450	400	350
		D	680	640	600	550	490	440	390	350	300	250
	Low Cool	A	710	670	620	570	510	470	420	380	330	280
		B	590	560	510	450	400	350	300	250	190	150
		C	550	510	470	410	370	310	270	210	160	120
		D	490	460	420	360	330	280	240	190	140	100
	High Heat	A	890	860	820	790	740	680	650	600	560	520
		B	800	760	720	680	620	580	530	490	440	400
		C	720	680	640	590	530	480	430	390	340	290
		D	690	650	610	560	500	450	400	360	310	260
	Low Heat	A	890	860	820	790	740	680	650	600	560	520
		B	790	750	710	660	600	570	520	480	430	380
		C	670	630	590	530	480	430	380	330	280	230
		D	640	610	560	500	450	400	350	310	250	210
PCG6A24075	High Cool	A	840	800	770	730	680	630	590	530	490	450
		B	770	730	700	650	600	530	490	440	400	360
		C	640	600	560	500	450	400	350	300	240	200
		D	580	550	500	440	390	350	290	240	180	130
	Low Cool	A	580	550	500	440	390	350	290	240	180	130
		B	290	270	250	220	200	170	150	120	90	60
		C	290	270	250	220	200	170	150	120	90	60
		D	290	270	250	220	200	170	150	120	90	60
	High Heat	A	1170	1140	1110	1080	1050	1030	990	960	920	890
		B	1060	1030	1000	970	940	900	870	830	790	730
		C	960	930	900	860	830	790	750	690	650	600
		D	870	830	800	760	720	670	620	570	520	490
	Low Heat	A	1180	1160	1130	1100	1070	1050	1010	980	940	910
		B	1060	1030	1000	970	940	900	870	830	790	730
		C	960	930	900	860	830	790	750	690	650	600
		D	820	790	750	710	670	610	570	510	470	430

Continued on following pages. See Notes at end of table.

**Table 13: Airflow Performance - Side Duct Application (Continued)**

Model	Jumper Position		External Static Pressure (in. W.C.)									
			0.1	0.2	0.3	0.4	0.5	0.6	0.7	0.8	0.9	1.0
			SCFM	SCFM	SCFM	SCFM	SCFM	SCFM	SCFM	SCFM	SCFM	SCFM
PCG6A36075	High Cool	A	1280	1240	1200	1160	1120	1070	1020	970	920	870
		B	1180	1140	1090	1050	1000	940	890	850	800	750
		C	1010	970	920	860	800	750	700	660	610	570
		D	940	890	840	770	720	670	620	570	530	480
	Low Cool	A	940	890	840	770	720	670	620	570	530	480
		B	860	810	730	680	630	580	530	470	420	370
		C	800	740	650	600	550	500	450	390	330	280
		D	710	640	560	510	450	390	340	260	190	130
	High Heat	A	1040	1000	950	890	840	780	730	690	640	600
		B	930	870	810	750	700	650	600	550	510	460
		C	860	810	730	680	630	580	530	470	420	370
		D	810	760	670	620	570	520	470	410	360	300
	Low Heat	A	880	820	750	700	640	590	550	490	440	390
		B	690	620	550	490	430	370	320	230	160	100
		C	490	440	390	350	310	270	230	160	110	70
		D	350	310	270	250	220	190	160	110	80	50
PCG6A36100	High Cool	A	1340	1300	1260	1220	1170	1120	1070	1020	960	920
		B	1210	1170	1120	1070	1020	960	910	860	810	770
		C	1010	950	890	830	760	710	660	620	570	500
		D	920	860	790	720	670	610	560	510	450	330
	Low Cool	A	940	880	810	750	690	640	580	540	480	370
		B	800	740	660	590	540	490	440	370	310	100
		C	480	440	390	350	330	290	260	220	180	60
		D	400	370	330	290	270	240	220	190	150	50
	High Heat	A	1670	1640	1600	1570	1530	1490	1450	1410	1360	1330
		B	1530	1490	1450	1410	1370	1330	1280	1230	1170	1120
		C	1340	1300	1260	1220	1170	1120	1070	1020	960	920
		D	1270	1230	1180	1140	1090	1030	980	930	880	840
	Low Heat	A	1410	1370	1340	1300	1250	1210	1160	1110	1050	1000
		B	1270	1230	1180	1140	1090	1030	980	930	880	840
		C	1150	1100	1050	1000	950	890	830	790	740	700
		D	980	930	870	810	740	690	630	590	540	460
PCG6B48065	High Cool	A	1760	1720	1680	1640	1610	1570	1520	1480	1440	1390
		B	1660	1620	1570	1540	1500	1460	1420	1370	1330	1280
		C	1480	1440	1390	1350	1300	1260	1210	1170	1110	1050
		D	1330	1280	1240	1190	1140	1090	1030	980	920	850
	Low Cool	A	1390	1340	1300	1250	1200	1150	1100	1050	990	920
		B	1330	1280	1240	1190	1140	1090	1030	980	920	850
		C	1080	1020	970	910	850	780	700	650	580	520
		D	880	820	740	670	590	530	470	380	190	230
	High Heat	A	1190	1130	1080	1030	970	910	840	790	730	660
		B	1120	1070	1020	960	900	830	760	700	640	580
		C	1010	940	880	820	750	680	610	550	440	410
		D	910	840	770	700	620	560	500	420	240	270
	Low Heat	A	1160	1110	1060	1000	950	880	810	760	700	630
		B	960	890	830	760	690	620	550	480	340	340
		C	830	760	690	610	520	470	410	320	100	160
		D	500	460	410	360	310	280	240	190	60	100

Continued on following pages. See Notes at end of table.

Table 13: Airflow Performance - Side Duct Application (Continued)

Model	Jumper Position		External Static Pressure (in. W.C.)									
			0.1	0.2	0.3	0.4	0.5	0.6	0.7	0.8	0.9	1.0
			SCFM	SCFM	SCFM	SCFM	SCFM	SCFM	SCFM	SCFM	SCFM	SCFM
PCG6B48100	High Cool	A	1760	1720	1680	1640	1610	1570	1520	1480	1440	1390
		B	1660	1620	1570	1540	1500	1460	1420	1370	1330	1280
		C	1480	1440	1390	1350	1300	1260	1210	1170	1110	1050
		D	1330	1280	1240	1190	1140	1090	1030	980	920	850
	Low Cool	A	1390	1340	1300	1250	1200	1150	1100	1050	990	920
		B	1330	1280	1240	1190	1140	1090	1030	980	920	850
		C	1080	1020	970	910	850	780	700	650	580	520
		D	880	820	740	670	590	530	470	380	190	230
	High Heat	A	1790	1750	1710	1670	1640	1600	1550	1510	1470	1430
		B	1600	1550	1510	1470	1430	1380	1340	1300	1250	1200
		C	1410	1360	1320	1270	1220	1170	1120	1070	1020	950
		D	1330	1280	1240	1190	1140	1090	1030	980	920	850
	Low Heat	A	1480	1440	1390	1350	1300	1260	1210	1170	1110	1050
		B	1330	1280	1240	1190	1140	1090	1030	980	920	850
		C	1210	1160	1110	1050	1000	940	870	820	760	690
		D	1030	970	910	850	790	720	640	580	480	450
PCG6B48125	High Cool	A	1760	1720	1680	1640	1610	1570	1520	1480	1440	1390
		B	1660	1620	1570	1540	1500	1460	1420	1370	1330	1280
		C	1480	1440	1390	1350	1300	1260	1210	1170	1110	1050
		D	1330	1280	1240	1190	1140	1090	1030	980	920	850
	Low Cool	A	1390	1340	1300	1250	1200	1150	1100	1050	990	920
		B	1330	1280	1240	1190	1140	1090	1030	980	920	850
		C	1080	1020	970	910	850	780	700	650	580	520
		D	880	820	740	670	590	530	470	380	190	230
	High Heat	A	2080	2020	1980	1930	1880	1830	1800	1740	1660	1580
		B	2040	2000	1960	1920	1880	1840	1800	1760	1710	1670
		C	1870	1830	1790	1750	1720	1680	1630	1590	1550	1520
		D	1700	1660	1620	1580	1540	1500	1460	1420	1380	1330
	Low Heat	A	2080	2020	1980	1930	1880	1830	1800	1740	1660	1580
		B	2040	2000	1960	1920	1880	1840	1800	1760	1710	1670
		C	1580	1540	1490	1450	1410	1370	1320	1280	1230	1180
		D	1440	1400	1350	1310	1260	1210	1170	1120	1070	1000
PCG6B60065	High Cool	A	1960	1930	1890	1850	1820	1790	1740	1700	1660	1630
		B	1880	1850	1810	1770	1740	1700	1660	1630	1590	1550
		C	1650	1610	1570	1530	1490	1460	1420	1380	1340	1300
		D	1470	1420	1380	1340	1290	1260	1210	1160	1110	1060
	Low Cool	A	1450	1400	1360	1310	1270	1230	1180	1130	1080	1030
		B	1410	1360	1320	1270	1220	1190	1130	1080	1030	970
		C	1130	1070	1020	960	900	820	760	710	650	610
		D	1030	970	900	840	760	690	620	570	490	450
	High Heat	A	1280	1220	1180	1130	1070	1030	970	910	850	790
		B	1130	1070	1020	960	900	820	760	710	650	610
		C	1030	970	900	840	760	690	620	570	490	450
		D	870	800	710	620	550	480	400	360	230	140
	Low Heat	A	1230	1170	1120	1070	1010	960	900	840	780	730
		B	1090	1020	960	910	840	750	690	640	580	550
		C	870	800	710	620	550	480	400	360	230	140
		D	650	590	520	440	380	330	260	230	110	30

See Notes at end of table on next page.

**Table 13: Airflow Performance - Side Duct Application (Continued)**

Model	Jumper Position		External Static Pressure (in. W.C.)									
			0.1 SCFM	0.2 SCFM	0.3 SCFM	0.4 SCFM	0.5 SCFM	0.6 SCFM	0.7 SCFM	0.8 SCFM	0.9 SCFM	1.0 SCFM
PCG6B60100	High Cool	A	1960	1930	1890	1850	1820	1790	1740	1700	1660	1630
		B	1880	1850	1810	1770	1740	1700	1660	1630	1590	1550
		C	1650	1610	1570	1530	1490	1460	1420	1380	1340	1300
		D	1470	1420	1380	1340	1290	1260	1210	1160	1110	1060
	Low Cool	A	1450	1400	1360	1310	1270	1230	1180	1130	1080	1030
		B	1410	1360	1320	1270	1220	1190	1130	1080	1030	970
		C	1130	1070	1020	960	900	820	760	710	650	610
		D	1030	970	900	840	760	690	620	570	490	450
	High Heat	A	1730	1690	1660	1620	1580	1540	1510	1470	1440	1400
		B	1540	1500	1460	1420	1380	1340	1300	1260	1220	1170
		C	1410	1360	1320	1270	1220	1190	1130	1080	1030	970
		D	1330	1270	1230	1180	1130	1100	1040	980	910	850
	Low Heat	A	1580	1540	1500	1460	1420	1380	1340	1300	1260	1210
		B	1330	1270	1230	1180	1130	1100	1040	980	910	850
		C	1180	1120	1070	1020	950	890	830	770	710	670
		D	1030	970	900	840	760	690	620	570	490	450
PCG6B60125	High Cool	A	1960	1930	1890	1850	1820	1790	1740	1700	1660	1630
		B	1880	1850	1810	1770	1740	1700	1660	1630	1590	1550
		C	1650	1610	1570	1530	1490	1460	1420	1380	1340	1300
		D	1470	1420	1380	1340	1290	1260	1210	1160	1110	1060
	Low Cool	A	1450	1400	1360	1310	1270	1230	1180	1130	1080	1030
		B	1410	1360	1320	1270	1220	1190	1130	1080	1030	970
		C	1130	1070	1020	960	900	820	760	710	650	610
		D	1030	970	900	840	760	690	620	570	490	450
	High Heat	A	2200	2160	2130	2090	2060	2020	1980	1980	1940	1910
		B	2060	2020	1990	1960	1920	1880	1840	1800	1770	1730
		C	1920	1890	1850	1810	1780	1740	1700	1660	1630	1590
		D	1760	1720	1690	1650	1610	1570	1530	1500	1460	1430
	Low Heat	A	2200	2160	2130	2090	2060	2020	1980	1980	1940	1910
		B	1970	1940	1910	1870	1830	1800	1750	1720	1680	1640
		C	1680	1650	1610	1570	1530	1500	1460	1420	1390	1350
		D	1670	1630	1590	1550	1510	1480	1440	1400	1360	1320

**Notes:**

Airflow tested with dry coil conditions, without air filters, at 230 V.

Applications above 0.8 in. W.C. external static pressure are not recommended.

Brushless DC high efficiency enhanced ECM blower motor used for all indoor blower assemblies.

Minimal variations in airflow performance data result from operating at 208 V. The data in the table can be used in those cases.

The differences between side duct airflows and bottom duct airflows are insignificant.

Heating applications are tested at 0.50 in. W.C. external static pressure. Cooling applications are tested per AHRI Standard 210/240.

**Table 14:** Additional Static Resistance

Size (Tons)	CFM	Wet Indoor Coil	Economizer <sup>1</sup>	Filter/Frame Kit
024 (2.0)	500	0.01	0.00	0.01
	600	0.01	0.00	0.02
	700	0.01	0.00	0.04
	800	0.02	0.01	0.06
	900	0.03	0.01	0.08
	1000	0.04	0.01	0.10
	1100	0.05	0.01	0.13
036 (3.0)	1200	0.06	0.02	0.16
	700	0.01	0.00	0.04
	800	0.02	0.01	0.06
	900	0.03	0.01	0.08
	1000	0.04	0.01	0.10
	1100	0.05	0.01	0.13
	1200	0.06	0.02	0.16
048 (4.0)	1300	0.07	0.03	0.17
	1400	0.08	0.04	0.18
	1100	0.02	0.02	0.04
	1200	0.03	0.02	0.04
	1300	0.04	0.02	0.05
	1400	0.05	0.03	0.05
	1500	0.06	0.04	0.06
	1600	0.07	0.04	0.07
	1700	0.07	0.04	0.08
060 (5.0)	1800	0.08	0.04	0.09
	1900	0.09	0.05	0.10
	2000	0.09	0.05	0.11
	1100	0.02	0.02	0.04
	1200	0.03	0.02	0.04
	1300	0.04	0.02	0.05
	1400	0.05	0.03	0.05
	1500	0.06	0.04	0.06
	1600	0.07	0.04	0.07
1700	0.07	0.04	0.08	
1800	0.08	0.04	0.09	
1900	0.09	0.05	0.10	
2000	0.09	0.05	0.11	

1. The pressure drop through the economizer is greater for 100% outdoor air than for 100% return air. If the resistance of the return air duct is less than 0.25 IWG, the unit delivers less CFM during full economizer operation.

**Note:** Filter pressure drop based on standard filter media tested at velocities not to exceed 300 ft/min.

## SECTION VI: OPERATION

The unit is controlled by a conventional heating/cooling thermostat.

If an electronic thermostat is used, make sure it has a common connection. DO NOT use a power stealing thermostat.

The unit has two stages of gas heat, and two stages of electric cooling. The unit can be controlled using a single stage heat/single stage cool (1H/1C) thermostat, but the second stage cooling is not available unless the unit control is physically wired for full capacity cooling operation. For optimum performance, it is best practice to use a two stage heat/two stage cool (2H/2C) thermostat.

### HEATING SEQUENCE OF OPERATION

#### Heating

The control board begins a call for heat when W1 is energized (connected to R).

The control checks if the pressure switch is open. If the pressure switch is closed, the control board flashes "2" on the LED and waits indefinitely for it to open. When the pressure switch is sensed as open, the control begins pressure switch proving period. If the call for heat is removed, the control goes back to standby.

The unit control contains a built-in second stage heating HI HEAT DELAY jumper that can automatically stage up to full capacity heating operation based on first stage heating call timing. Built-in heating stage up selection is an OFF, 10-minute, 15-minute, or 20-minute timer. Based on HI HEAT DELAY jumper selection, the control is automatically staged up to high heat during a call for low heat on the W1 input terminal. This timing starts over with each new call for heat. Regardless of the HI HEAT DELAY jumper setting, if the control is operating in low heat (W1) and a 24 VAC signal is received on the high heat input (W2), the control is staged up to full capacity heating operation. When using the built-in HI HEAT DELAY feature and the control has staged up to full capacity heating, the unit remains in full capacity heating until the call for heat on the W1 input is terminated. If using a two stage heating thermostat, set the HI HEAT DELAY jumper to the OFF position.

#### Pressure Switch Proving

The control board energizes the induced draft motor and waits for the pressure switch to close. When the pressure switch closes, the control begins pre-purge period. If the call for heat is removed, the control de-energizes the inducer without post-purge and returns to standby.

If the pressure switch does not close within 5 seconds of inducer energizing, the control board flashes "3" on the LED. If the pressure switch does not close within 60 seconds of inducer energizing, the control shuts off the inducer for 60 seconds, then energizes the inducer for another 60 seconds in an attempt to close the pressure switch. This cycle continues indefinitely until the pressure switch is proved closed or the call for heat ends.

#### Pre-Purge

The control board monitors the pressure switch and ensures it remains closed during pre-purge. If the pressure switch opens, the control goes back to pressure switch proving mode. The control waits for a 15-second pre-purge period, then begins the ignition trial.

#### Ignition Trial Period

The control board energizes the gas valve and spark outputs for a 5-second ignition trial. The control de-energizes the spark when flame is sensed and enters a flame stabilization period.

The unit control establishes flame in HI HEAT mode. If a call for heating is only present on the first stage heating (W1) input, the control switches to first stage heat after 10 seconds of flame. If there is a heat call on the first and second stage input (W1 + W2), the control remains in high heat mode.

If flame is not established within the ignition trial period, the control de-energizes the spark and gas valve and begins an inter-purge period before attempting another ignition trial.

If the call for heat is removed during an ignition trial period, the control immediately de-energizes spark and gas. The control runs the inducer motor through a post purge period before de-energizing.

If the pressure switch opens during an ignition trial period, the control immediately de-energizes spark and gas. The control begins pressure switch proving before an inter-purge and reignition attempt.

### Heat Blower On Delay

The control board waits for 30 seconds and then energizes the indoor blower heat speed. The indoor blower heat speed is based on the HEAT airflow selection jumper, and the low heating (W1) or the high heating (W1+W2) input.

Blower on delay time begins at the start of flame proving period in the trial for ignition.

If the thermostat demand for heat is removed, the control de-energizes the gas valve, energizes the blower on heat speed, and initiates a post purge and heat blower off delay.

### Main Burner Operation

The control board keeps the main gas valve and induced draft motor energized while continuously monitoring the call for heat, pressure switch, and flame status.

If the call for heat (W1) is removed, the control de-energizes the gas valve and begins the post purge and heat blower off delay.

If a call for low fire heat (W1) is present and a call for high stage heat (W2) is removed, the control is staged down to low fire heat. The control is staged back up to high fire heat if the high stage heat (W2) call is re-applied to the control. During normal operation, if the control is operating the unit in low stage heat, the control is switched to high fire heat any time a call for high stage heat (W2) is applied to the control, regardless of the setting on the HI HEAT DELAY jumper.

If the pressure switch opens, the control de-energizes the gas valve and begins pressure switch proving mode.

If flame is removed, the control de-energizes the gas valve within 2.0 seconds and counts the flame loss. If flame has been lost less than 5 times, the control attempts reignition after a 15-second inter-purge period. If flame has been lost 5 times within the same call for heat, the control board locks out, and flashes a sequence of "8" times on the LED.

### Post Purge

The control board runs the induced draft motor for a 15-second post purge period and then de-energizes the inducer. If a call for heat occurs during post purge, the control finishes the post purge and immediately begins the next ignition sequence.

### Heat Blower Off Delay

After a heating sequence, the control board de-energizes the indoor blower motor after a delay time as selected by a movable shunt (60, 90, 120, or 180 seconds). Blower off timing begins when the thermostat is satisfied and removes the (W1) call for heat. The control returns to standby when the blower off delay is complete.

If the thermostat call for heat returns before the blower off delay is complete, the control begins an ignition sequence with pre-purge while the blower off delay continues.

### Lockout

While in lockout, the control board keeps the main gas valve and induced draft motor de-energized.

Lockouts due to failed ignition or flame losses can be reset by removing the call for heat (W1) for more than 1 second or removing power from the control for over 0.25 second. The control automatically resets from lockout after 60 minutes.

Lockouts due to detected internal control faults reset after 60 minutes or power interruption. Cooling operations are available during a heating lockout.

### High Temperature Limit Switch

Any time the high temperature limit switch is open for less than 5 minutes, the control board runs the indoor blower motor on high heat speed, runs the inducer, de-energizes the gas valve, and flashes a sequence of "4" times on the LED. When the high temperature switch closes, the control restarts the ignition sequence, beginning with pre-purge.

If the limit switch has been open for more than 5 minutes, the control de-energizes the inducer, continues to operate the indoor blower motor on heat speed, and flashes a sequence of "11" times on the LED.

### Rollout Switch

If the limit circuit is open for more than 15 minutes, the control board flashes a sequence of "5" times on the LED. The blower output energizes on high heat speed during an open rollout condition.

If the rollout switch is reset, the control remains locked out until power is removed or a call for heat (W) is removed.

Rollout switch lockout does not reset automatically.

### Power Interruptions

Power interruptions of any duration do not cause lockout or any operation requiring manual intervention.

### Flame Present with Gas Off

If flame is sensed for longer than 4.0 seconds during a period when the gas valve should be closed, the control enters a lockout, flashing "1" time on the LED. The control energizes the inducer blower while the flame is sensed.

## AIRFLOW SETTINGS

### Cooling Airflow Settings

The unit is equipped with an electronically commutated (ECM) blower motor. The motor and blower can deliver airflow over a wide range of operating conditions.

Select the required cooling airflow by placing the Cool jumper on the control board in the required position: A, B, C, or D. The A position gives the highest airflow and the D position gives the lowest airflow. See Table 13 for the expected airflow at each speed setting. Select the speed to deliver approximately 350 CFM to 400 CFM per ton of A/C cooling capacity. Use of airflow outside this range may cause diminished air conditioning performance, lower overall energy efficiency, and higher electric utility bills. See Table 15 for default cooling blower settings.

**Table 15:** Default Blower Speeds

Model Number	Default Blower Speeds	
	Heat Jumper	Cool Jumper
PCG6A24050	B	A
PCG6A24075	B	A
PCG6A36075	B	A
PCG6A36100	C	A
PCG6B48065	B	A
PCG6B48100	B	A
PCG6B48125	C	A
PCG6B60065	A	A
PCG6B60100	B	A
PCG6B60125	C	A



## Continuous Fan Airflow Settings

To operate the furnace in continuous fan mode, set the wall thermostat Fan switch to On. The default continuous fan setting is with the Cool jumper in the D position. During continuous fan operation, the blower delivers approximately 67% of the high stage cooling airflow.

## Gas Heating Airflow Settings

See Table 15 for the default heating blower speed. The unit is equipped with an electronically commutated (ECM) blower motor. The motor and blower can deliver airflow over a wide range of operating conditions.

Select the required heating airflow by placing the Heat jumper on the control board in the required position: A, B, C, or D. The A position gives the highest airflow and the D position gives the lowest airflow. See Table 13 for the expected airflow at each speed setting. See Table 15 for the default heating blower speed for each model.

In certain circumstances, it may be necessary to move the heating blower speed to a different motor speed tap. Not all of the motor heating speeds are appropriate for gas heating operation for all models and applications. Use of heating airflow at a speed other than the default speed causes diminished heating performance and may cause the furnace temperature limit controls to shut down the furnace.

## Measurement of Temperature Rise

### DANGER

*The temperature rise, or temperature difference between the return air and the supply (heated) air from the furnace, must be within the range shown on the furnace rating plate and within the application limitations shown in Table 7 "Physical Data".*

*The supply air temperature cannot exceed the "Maximum Supply Air Temperature" specified in these instructions and on the furnace rating plate. Under NO circumstances can the furnace be allowed to operate above the Maximum Supply Air Temperature. Operating the furnace above the Maximum Supply Air Temperature will cause premature heat exchanger failure, high levels of Carbon Monoxide, a fire hazard, personal injury, property damage, and/or death.*

After about 5 minutes of operation, determine the furnace temperature rise. Measure the temperature of the return air and the heated air in the ducts about 6 ft (1.83 m) from the furnace, where they are not affected by radiant heat. Increase the blower speed to decrease the temperature rise. Decrease the blower speed to increase the temperature rise.

## GAS VALVE FAULT

If the main valve output is sensed to be energized for more than 1 second when commanded to be off, the control de-energizes the induced draft motor (if flame is not present) to attempt to open the pressure switch to de-energize the gas valve. If the main gas valve still senses being energized after the inducer has been off for 10 seconds, the control re-energizes the inducer to vent the unburned gas. The control enters a hard lockout, flashing a sequence of "10" times on the LED.

The only way to recover from a hard lockout is to remove and reapply 24 VAC power to the control board.

## Safety Controls

The control circuit includes the following safety controls:

- **Limit Switch (LS)** - This control is located inside the blower compartment and protrudes into the heat exchanger compartment. The limit switch is set to open at a temperature selected to prevent the outlet air temperature from exceeding the maximum shown on the unit rating plate. It resets automatically. The limit switch operates when a high temperature condition occurs. The limit switch shuts down the ignition control, closes the main gas valve, and energizes the blower.
- **Pressure Switch (PS)** - If the draft motor fails, the pressure switch prevents the ignition control and gas valve from being energized.
- **Flame Sensor** - The flame sensor is located on the left-most burner. If an ignition control fails to detect a signal from the flame sensor indicating the flame is properly ignited, the main gas valve closes.
- **Rollout Switch (RS)** - This switch is located on the burner assembly. In the event of a sustained main burner flame rollout, the control closes the main gas valve. This is a manual reset type switch.

## NOTICE

*The manual reset Rollout Switch (RS) must be reset before allowing furnace operation.*

## GAS HEATING FAULT CODES

The gas heating section has built-in self-diagnostic capability. A blinking LED light on the control board can flash red, green, or amber to indicate various conditions. The control continuously monitors its own operation and the operation of the system. If a fault occurs, the LED light indicates the fault code.

The slow flash speed is 2 seconds on and 2 seconds off. The other flash codes listed below have the following timing: The LED light turns on for 1/3 second and off for 1/3 second. This pattern is repeated the number of times equal to the code. There is a two-second pause between codes. For example, the 6 Red Flashes fault code means the LED light flashes on and off six times and then remains off for 2 seconds. This pattern repeats as long as the fault condition remains. The continuous flash codes listed below mean the LED light flashes on and off continuously with no breaks or longer pauses.

**Slow Green Flash:** Indicates normal operation with no thermostat calls. Standby mode.

**Slow Amber Flash:** Indicates normal operation with a call for heat.

**LED Steady Off:** If the LED light does not flash at all, check for power to the control board and check for an open fuse on the control board. If the control board is properly powered and the fuse is not open, the control board may need to be replaced.

**Steady On Any Color:** Indicates a possible control failure. Turn the power to the furnace off and back on. If the fault code recurs, the control board must be replaced. The control board is not field-repairable.

**Rapid Amber Flash:** Indicates the flame sense current is below 1.5 VDC. Check and clean the flame sensor. Check for proper gas flow. Verify that the current is greater than 1.5 VDC at the flame current test pad.

**4 Amber Flashes:** Indicates the control is receiving a Y signal from the thermostat without a G signal. The furnace operates normally during heating and cooling, but this fault code is displayed to alert the user that there is a wiring problem. Verify that the G wire from the thermostat is connected properly.

**1 Red Flash:** Indicates flame was sensed when there was no call for heat. The control turns on both the inducer motor and supply air blower. Check for a leaking or slow-closing gas valve.

**2 Red Flashes:** Indicates the pressure switch is closed when it should be open. The control confirms the pressure switch contacts are open at the beginning of each heat cycle. The control prevents the ignition sequence from continuing if the pressure switch contacts are closed when they should be open. Check for a faulty pressure switch or miswiring.

**3 Red Flashes:** Indicates the pressure switch contacts are open when they should be closed. Check for the following:

- Faulty inducer
- Blocked vent
- Broken pressure switch hose
- Disconnected pressure switch or inducer wires
- Faulty pressure switch

**4 Red Flashes:** Indicates the main limit or rollout switch has opened its contacts, which are normally closed. The control turns on the supply air blower and inducer. Check for the following:

- Dirty filter
- Improperly sized duct system
- Incorrect blower speed setting
- Incorrect firing rate
- Loose limit switch or rollout switch wiring
- Faulty blower motor

If the limit switch does not close within 5 minutes, the control operates as if the blower is not functioning. The control starts a hard lockout and flashes the 11 Red Flashes fault code. If the limit switch does not close after 15 minutes, the control operates as if a manual-reset rollout switch has opened, and flashes the 5 Red Flashes fault code. See the 5 Red Flashes and 11 Red Flashes descriptions below. If the main limit switch opens five times within a single call for heat, the control flashes the 4 Red Flashes fault code and enters a one-hour soft lockout.

**5 Red Flashes:** Indicates the limit circuit has been open for more than 15 minutes, usually meaning that a manual-reset rollout switch has opened. Check for proper combustion air, proper inducer operation, primary heat exchanger failure, or a burner problem. The control enters a hard lockout. After the problem is corrected, you must turn the power off and back on to reset the control.

**6 Red Flashes:** Indicates that while the unit was operating, the pressure switch opened four times during the call for heat. Check for a faulty inducer, blocked vent, or faulty pressure switch. The furnace locks out for 1 hour and then restarts.

**7 Red Flashes:** Indicates the flame could not be established during three attempts for ignition. Check that the gas valve switch is in the On position. Check for the following:

- Low gas pressure or no gas pressure
- Faulty gas valve
- Dirty or faulty flame sensor
- Faulty hot surface ignitor
- Loose wires
- Burner problem

The furnace locks out for 1 hour and then restarts.

**8 Red Flashes:** Indicates the flame has been lost five times (four recycles) during the heating cycle. Check for low gas pressure, a dirty or faulty flame sensor, or a faulty gas valve. The furnace locks out for 1 hour and then restarts.

**9 Red Flashes:** Indicates reversed line voltage polarity, a grounding problem, or reversed low voltage transformer wires. Check the polarity at the furnace and branch. Check the furnace grounding. Check that the flame probe is not shorted to chassis. The furnace does not start the ignition sequence until this problem is corrected.

**10 Red Flashes:** Indicates the gas valve is energized with no call for heat. The main blower and inducer blower run and no ignition sequence starts as long as this condition exists. Check the gas valve and gas valve wiring.

**11 Red Flashes:** Indicates the limit circuit has remained open for more than 5 minutes and less than 15 minutes. This condition is usually caused by a failed blower motor or blower wheel. The control enters a hard lockout. After the problem is corrected, you must turn the power off and back on to reset the control.

**12 Red Flashes:** Indicates the ID plug is not present or not connected properly. Check for a loose plug or loose wires in the plug.

**Soft Lockout:** The control includes a soft lockout that resets automatically after 1 hour. This provides protection for an unoccupied structure if a temporary condition causes a furnace malfunction, for example, if a temporary interruption in gas supply prevents the furnace from lighting. In this case, the control keeps trying to light each hour and resumes normal operation if the gas supply is restored.

**Hard Lockout:** Some fault conditions cause a hard lockout, and you must turn the power to the control off and back on to reset the control. The control does not automatically restart.

## COOLING SEQUENCE OF OPERATIONS

When the thermostat calls for COOL, the thermostat terminals G and Y1 are energized, which signals the compressor, outdoor fan, and indoor blower to run on first stage cooling.

With a call for Y1, the indoor circulating blower is energized at LOW COOL speed.

The control cycles the compressor and indoor blower to second stage cooling speed anytime a second stage cooling (Y2) call is received during a first stage cooling (Y1) call. The control does not operate on second stage cooling without a call on the Y2 thermostat input.

When the thermostat is satisfied, terminals G and Y are de-energized, de-energizing the compressor and outdoor fan.

After a cool fan off delay timing of 30 seconds, the indoor circulating blower is de-energized.

## Dehumidification/Humidity Switch Input

This model unit features a built-in dehumidification feature for advanced dehumidification during cooling operation. The unit indoor blower control is designed to work with a humidity control that closes when the humidity is below the setpoint. The control is open when the humidity is above the setpoint. This humidity control may be referred to as a humidistat or dehumidistat.

To use this feature, the control HUM STAT jumper must be set to YES, the AC/HP jumper must be set to A/C, and a humidistat must be connected from the low voltage R and HUM color coded leads. During cooling operation, if the humidity level is above the humidistat setpoint, the indoor blower speed is reduced by approximately 15%.

## Safety Controls

### WARNING

*The ability to properly perform maintenance on this equipment requires certain expertise, mechanical skills, tools and equipment. If you do not possess these, do not attempt to perform any maintenance other than those procedures recommended in this Installation Manual. Failure to heed this warning could result in serious injury and possible damage to this equipment.*

The control circuit includes the following safety controls:

**High Pressure Switch (HPS)** - This switch protects against excessive discharge pressures due to a blocked outdoor coil or an outdoor motor failure (switch opens at 650 ± 25 psig and closes at 450 ± 25 psig).

**Loss of Charge Switch (LCS)** - This switch protects against loss of charge due to a leak in the system.

The above pressure switches are specifically designed to operate with R-410A systems. R-22 pressure switches must not be used as replacements for R-410A pressure switches.

## INDOOR CIRCULATING BLOWER

When the thermostat calls for FAN, the thermostat terminal G is energized, signaling the indoor blower control board to operate the circulating blower to run continuously. The circulating blower airflow is approximately 63% of the HIGH COOL airflow selected on the indoor blower control board.

If a call for COOL occurs on Y1, the indoor blower runs at the LOW COOL speed based on the COOL jumper setting. If a call for cool is present on Y1+Y2, the indoor blower runs at the HIGH COOL speed based on the COOL jumper setting.

If a call for HEAT occurs on W1 or W1+W2, the circulating blower runs at the heat speed based on the HEAT jumper setting.

When the thermostat ends the call for FAN, the thermostat terminal G is de-energized, and the indoor blower control board stops the circulating blower operation.

### Delay Profiles

The Delay Profiles are shown in Table 16 for each Delay jumper setting.

The levels shown in the Pre-Run, Short-Run, and Run periods are a percentage of the blower speed corresponding to the thermostat call.

The Post-Run and Off Delay levels are derived from the level of the previous state, not the blower speed corresponding to the thermostat call.

If in Delay Profile B and in the Short-Run period (82% of capacity) and the thermostat call is removed, this causes the control to enter the Post-Run state. The Post-Run state level for Delay Profile B is 100% of the previous level, so the level during the Post-Run state is 82%.

**Table 16:** Delay Profile Descriptions

Delay Profile	Period	Cooling	
		Level%	Time in State (Minutes)
A	Pre-Run	Bypass	Bypass
	Short-Run	Bypass	Bypass
	Run	100	No Limit
	Post-Run*	100	1
	Off Delay*	Bypass	Bypass
B	Pre-Run	50	2
	Short-Run	82	5
	Run	100	No Limit
	Post-Run*	100	1
	Off Delay*	Bypass	Bypass
C	Pre-Run	Bypass	Bypass
	Short-Run	Bypass	Bypass
	Run	100	No Limit
	Post-Run*	100	1
	Off Delay*	50	1
D	Pre-Run	Bypass	Bypass
	Short-Run	63	1.55
	Run	100	No Limit
	Post-Run*	100	1
	Off Delay*	63	0.5

## CHARGING

To check or adjust unit charge:

1. Connect a temperature probe to the compressor discharge line approximately 6 in. away from the compressor shell.
2. Connect a high side refrigerant pressure gauge to the unit discharge pressure port.
3. Record discharge line temperature and discharge pressure. Using an R410A temperature pressure chart, convert gauge pressure to saturation temperature. The difference between discharge saturation temperature and discharge line temperature is discharge superheat.
4. Obtain an entering indoor wet bulb temperature reading.

5. Compare readings taken to the unit charging chart.

## START-UP

### Prestart Check List

Complete the following checks before starting the unit.

- Check the type of gas being supplied. Ensure that it is the same as listed on the unit nameplate.
- Ensure that the vent outlet air hood and air intake hood have been properly installed.
- Set the airflow selection jumpers to the appropriate settings based on external static pressures and heating temperature rise. See Figure 9.

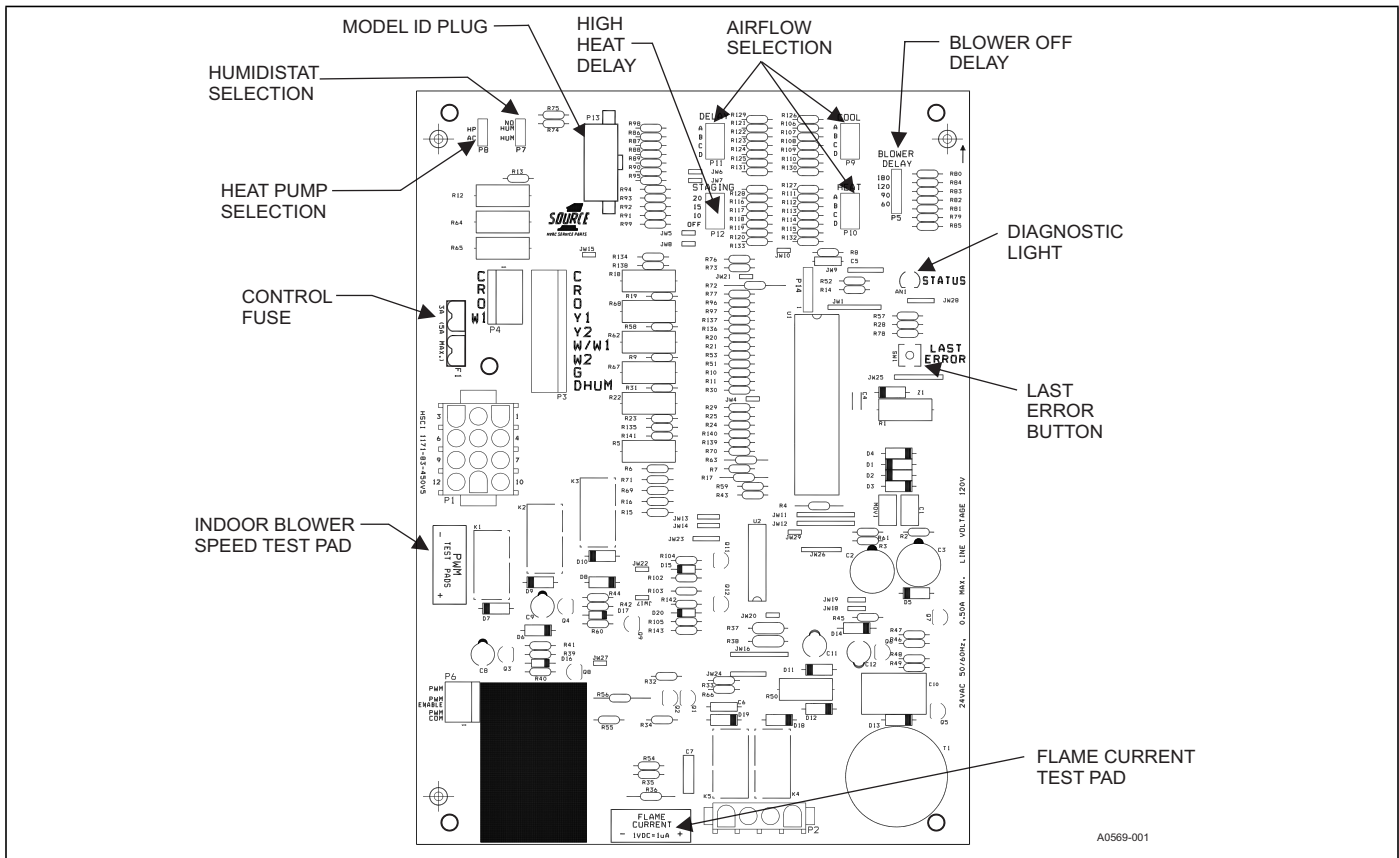

Figure 9: Control Board

## Operating Instructions

1. STOP! Read the safety information on the unit label.
2. Set the thermostat to the OFF position.
3. Turn off all electrical power to the unit.
4. DO NOT try to light the burners by hand. This appliance is equipped with an ignition device that automatically lights the burners.
5. Remove the control access panel.
6. Turn the gas valve switch to the OFF position.
7. Wait 5 minutes to clear out any gas. If you then smell gas, STOP! Follow B in the safety information on the unit label. If you don't smell gas, go to the next step.
8. Turn the gas valve switch to the ON position.
9. Replace the control access panel.
10. Turn on all electric power to the unit.
11. Set the thermostat to the required setting.
12. If the unit still does not operate, follow the instructions in the Turning Off Gas to Unit section, and call service technician or gas supplier.

## Turning Off Gas to Unit

1. Set the thermostat to the OFF position.
2. Turn off all electric power to the appliance if service is to be performed.
3. Remove the control access panel.
4. Turn the gas valve switch to the OFF position. DO NOT FORCE.
5. Replace the control access panel.

## Post Start Check List

After the entire control circuit has been energized and the heating section is operating, make the following checks:

- Check for gas leaks in the unit piping as well as the supply piping.
- Check for correct manifold gas pressures. See the CHECKING GAS HEAT INPUT section.
- Check the supply gas pressure. It must be within the limits shown on rating nameplate. Supply pressure must be checked with all gas appliances in the building at full fire. At no time must the standby gas line pressure exceed 13.5 in. W.C., nor the operating pressure drop below 4.5 in. W.C. for natural gas units. If gas pressure is outside these limits, contact the local gas utility for corrective action.

## ADJUSTMENT OF MANIFOLD GAS PRESSURE AND INPUT RATE

Inlet and manifold gas pressure can be measured by connecting the U tube manometer to the gas valve with a piece of tubing. Follow the appropriate section in the instructions below. See Figure 10 for the locations of the pressure ports on the gas valve.

**Turn off gas at the ball valve or gas cock on the gas supply line before the gas valve, and turn off the electrical supply. Find the pressure ports on the gas valve marked Out P and In P.**

1. Take the manifold pressure at the port marked OUT P.
2. Take the gas line pressure at the port marked IN P.
3. Using a 3/32 in. (2.4 mm) hex head wrench, loosen the set screw by turning it one turn counter clockwise. **DO NOT REMOVE THE SET SCREW FROM THE PRESSURE PORT.**

### Read the inlet gas pressure

Connect the positive side of the manometer to the port marked IN P on the gas valve. Do not connect any tubing to the negative side of the manometer to prevent atmospheric pressure from being referenced by the manometer. See Figure 11 for connection details.

1. Turn gas and electrical supplies on and follow the operating instructions to place the unit back in operation.

**Table 17:** Inlet Gas Pressure Range

INLET GAS PRESSURE RANGE		
	Natural Gas	Propane (LP)
Minimum	4.5 in. W.C. (1.12 kPa)	8.0 in. W.C. (1.99 kPa)
Maximum	10.5 in. W.C. (2.61 kPa)	13.0 in. W.C. (3.24 kPa)

**IMPORTANT:** The inlet gas pressure operating range table specifies what the minimum and maximum gas line pressures must be for the furnace to operate correctly. The gas line pressure **MUST BE** a minimum of:

- 7 in. W.C. (1.74 kPa) for Natural Gas
- 11 in. W.C. (2.74 kPa) for Propane (LP) Gas

This is in order to obtain the BTU input specified on the rating plate and/or the nominal manifold pressure specified in these instructions and on the rating plate.

2. Establish the correct gas inlet pressure in accordance with Table 17. Turn the gas valve to OFF, and turn the electrical supply switch to OFF. Remove the flexible tubing from the gas valve pressure port, and tighten the pressure port plug using the 3/32 in. (2.4 mm) hex head wrench.
3. Turn the electrical and gas supplies back on. With the burners in operation, check for gas leakage around the gas valve pressure port. Use an approved non-corrosive gas leak detection fluid or other non-flammable leak detection methods to do the leak check.

### Read the manifold gas pressure

Connect the positive side of the manometer to the port marked OUT P on the gas valve. Do not connect any tubing to the negative side of the manometer to prevent atmospheric pressure from being referenced by the manometer. See Figures 10 and 11 for connection details.

**IMPORTANT:** The cap for the pressure regulator must be removed entirely to gain access to the adjustment screw. Loosening or tightening the cap does not adjust the flow of gas.

## NOTICE

*The regulated outlet pressure has been calibrated at the factory. Additional pressure adjustment should not be necessary. If adjustment is necessary, set to the following specifications. After adjustment, check for gas leakage.*

This gas valve has separate regulator adjustment screws for high fire and low fire as shown in Figure 10. The procedure below is used to adjust either the high fire manifold pressure or the low fire manifold pressure.

## NOTICE

*Gas manifold pressure must be set on high fire before adjusting low fire pressure.*

1. See Figure 10 for location of pressure regulator adjustment cap and adjustment screws on main gas valve.
2. Turn on gas and electrical supplies, and follow the operating instructions to place the unit back in operation.
3. Connect unit control wiring leads W1, W2, and R together so the equipment operates on high fire. Once correct manifold pressure is set (HI), remove control wire lead W2 so the equipment operates on low fire. Set the manifold pressure (LO) to correct manifold pressure.

**Table 18:** Nominal Manifold Pressure

NOMINAL MANIFOLD PRESSURE	
Natural Gas (High Fire)	3.5 in. W.C. (0.87 kPa)
Natural Gas (Low Fire)	1.6 in. W.C. (0.40 kPa)
Propane (LP) Gas (High Fire)	9.8 in. W.C. (2.488 kPa)
Propane (LP) Gas (Low Fire)	4.0 in. W.C. (0.99 kPa)

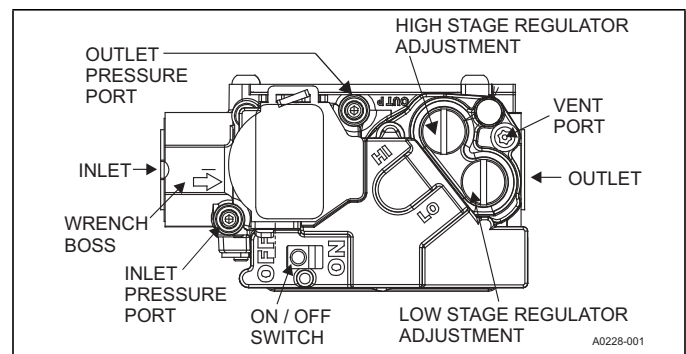

**Figure 10:** Gas Valve

**IMPORTANT:** If gas valve regulator screw is turned in (clockwise), manifold pressure is increased. If screw is turned out (counterclockwise), manifold pressure is decreased.

4. After the manifold pressure has been adjusted, re-calculate the furnace input to make sure you have not exceeded the specified input on the rating plate. See Natural Gas in the CHECKING GAS HEAT INPUT section.
5. Once the correct BTU (kW) input has been established, turn the gas valve to OFF, and turn the electrical supply switch to OFF. Remove the flexible tubing from the gas valve pressure port, and tighten the pressure port plug using the 3/32 in. (2.4 mm) hex head wrench.
6. Turn on electrical and gas supplies. With the burners in operation, check for gas leakage around the gas valve pressure port. Use an approved non-corrosive gas leak detection fluid or other non-flammable leak detection methods to do the leak check.

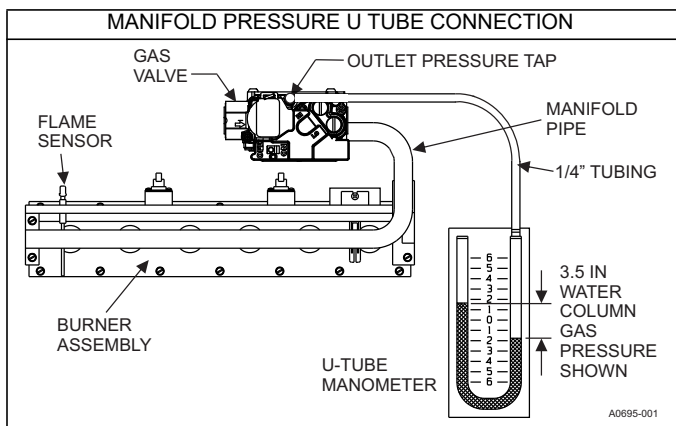

**Figure 11:** Reading Gas Pressure

## CHECKING GAS HEAT INPUT

### Natural Gas

1. Turn off all other gas appliances connected to the gas meter.
2. With the unit turned on, measure the time needed for one revolution of the hand on the smallest dial on the meter (a typical gas meter usually has a 1/2 ft<sup>3</sup> or a 1 ft<sup>3</sup> test dial).
3. Using the number of seconds for each revolution and the size of the test dial increment, find the cubic feet of gas consumed per hour from Table 19.

If the actual input is not within 5% of the unit input rating with allowance being made for the permissible range of the regulator setting, replace the orifice spuds with spuds of the proper size.

## NOTICE

*To find the BTU input, multiply the number of cubic feet of gas consumed per hour by the BTU content of the gas in your particular locality. Contact your gas company for this information since it varies widely from city to city.*

**Table 19:** Gas Rate (ft<sup>3</sup>/h)<sup>1</sup>

Seconds for One Revolution	Size of Test Dial	
	1/2 ft <sup>3</sup>	1 ft <sup>3</sup>
10	180	360
12	150	300
14	129	257
16	113	225
18	100	200
20	90	180
22	82	164
24	75	150
26	69	138
28	64	129
30	60	120
32	56	113
34	53	106
36	50	100
38	47	95
40	45	90
42	43	86
44	41	82
46	39	78
48	37	75
50	36	72
52	35	69
54	34	67
56	32	64
58	31	62
60	30	60

1. **Example:** By actual measurement, it takes 38 seconds for the hand on the 1 ft<sup>3</sup> dial to make a revolution with just a 100,000 BTUH furnace running. Using this information, locate 38 seconds in the first column of Table 19.

Read across to the 1 ft<sup>3</sup> column, and see that 95 ft<sup>3</sup>/h of gas are consumed by the furnace at that rate. Multiply 95 x 1050 (or the BTU rating of the gas obtained from the local gas company). The result is 99,750 BTUH, which is close to the 100,000 BTUH rating of the unit.

## MEASURING EXTERNAL STATIC PRESSURE

1. Measure the supply air static pressure and record this positive number.
2. Measure the return air static pressure and record this negative number.
3. Treat the negative number as a positive and add the two numbers together. This is the total external static pressure.

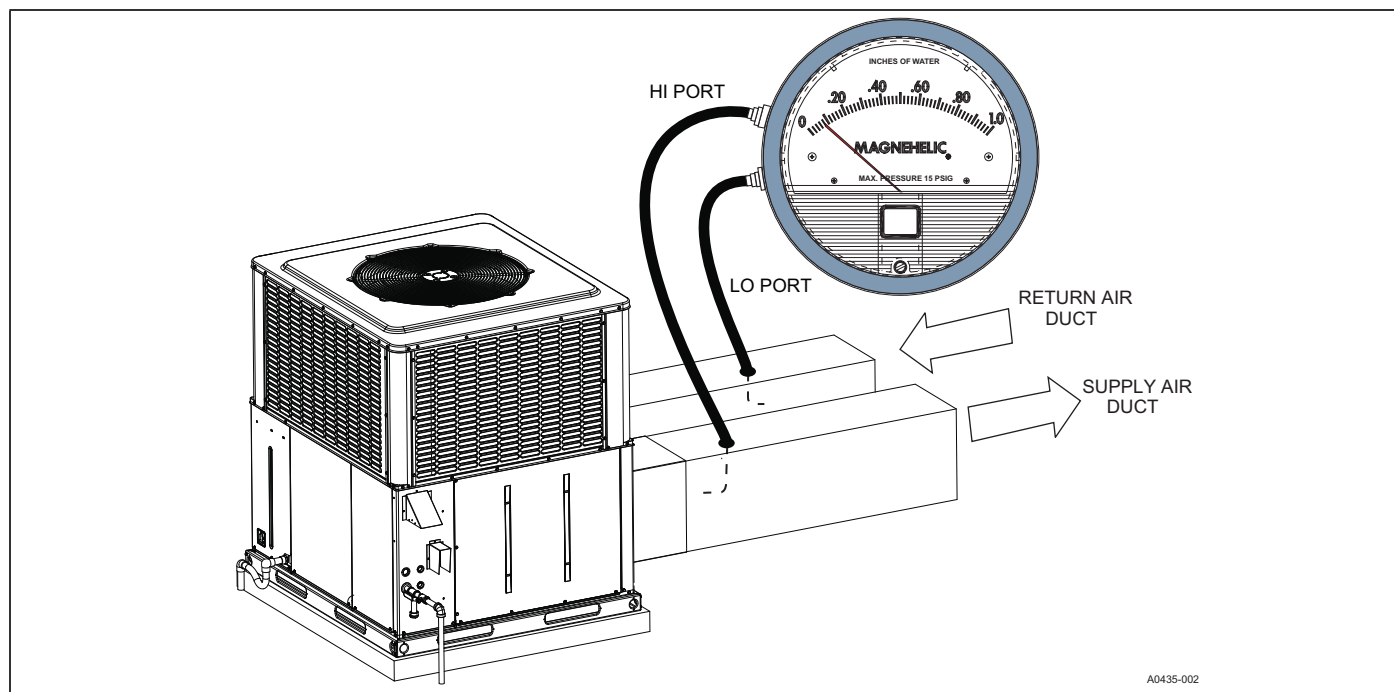

Figure 12: Measuring External Static Pressure

## R-410A QUICK REFERENCE GUIDE

### Refer to Installation Instructions for specific installation requirements

- R-410A refrigerant operates at 50 - 70 percent higher pressures than R-22. Be sure that servicing equipment and replacement components are designed to operate with R-410A.
- R-410A refrigerant cylinders are rose colored.
- Recovery cylinder service pressure rating must be 400 psig, DOT 4BA400, or DOT BW400.
- Recovery equipment must be rated for R-410A.
- **DO NOT** use R-410A service equipment on R-22 systems. All hoses, gages, recovery cylinders, charging cylinders and recovery equipment must be dedicated for use on R-410A systems only.
- Manifold sets must be at least 700 psig high side, and 180 psig low side, with 550 psig retard.
- All hoses must have a service pressure rating of 800 psig.
- Leak detectors must be designed to detect HFC refrigerants.
- Systems must be charged with liquid refrigerant. Use a commercial type metering device in the manifold hose.
- R-410A can only be used with POE type oils.
- POE type oils rapidly absorb moisture from the atmosphere.
- Vacuum pumps will **not** remove moisture from R-410A refrigerant oils.
- **Do not use** liquid line driers with a rated working pressure rating less than 600 psig.
- **Do not** install suction line driers in the liquid line.
- A liquid line drier is required on every unit.
- **Do not use** a R-22 TXV. If a TXV is to be used, it must be a R-410A TXV.
- Never open system to atmosphere when under a vacuum.
- If system must be opened for service, evacuate system then break the vacuum with dry nitrogen and replace all filter driers.

Figure 13: R-410A Quick Reference Guide

## NOTES



SECTION VII: TYPICAL WIRING DIAGRAMS

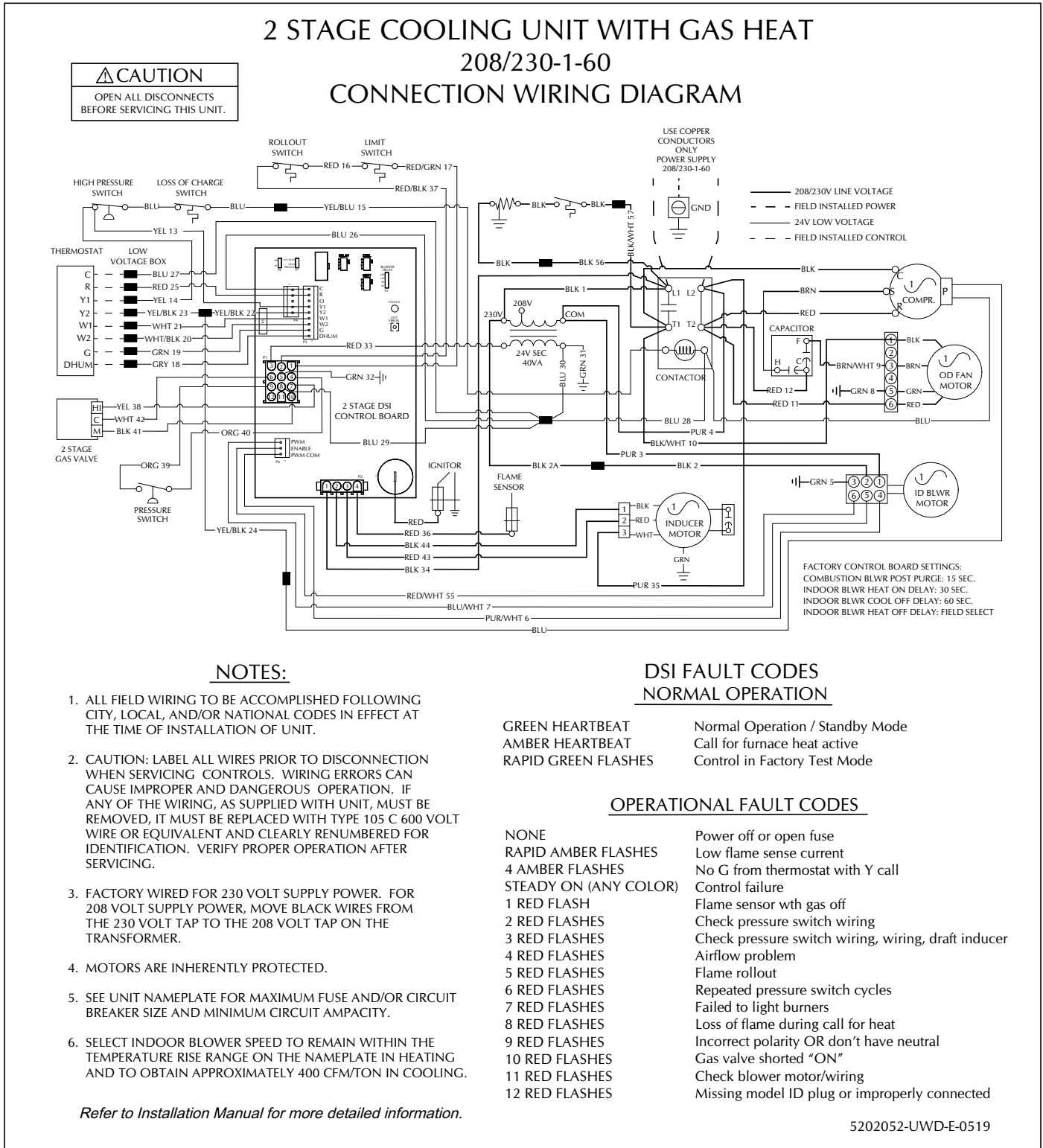

Figure 14: Connection Wiring Diagram

## 2 STAGE COOLING UNIT WITH GAS HEAT

### 208/230-1-60

### LADDER WIRING DIAGRAM

**CAUTION**

OPEN ALL DISCONNECTS  
BEFORE SERVICING THIS UNIT.

#### DSI FAULT CODES NORMAL OPERATION

<p>GREEN HEARTBEAT</p> <p>AMBER HEARTBEAT</p> <p>RAPID GREEN FLASHES</p>	<p>Normal Operation / Standby Mode</p> <p>Call for furnace heat active</p> <p>Control in Factory Test Mode</p>
--	--

#### OPERATIONAL FAULT CODES

<p>NONE</p> <p>RAPID AMBER FLASHES</p> <p>4 AMBER FLASHES</p> <p>STEADY ON (ANY COLOR)</p> <p>1 RED FLASH</p> <p>2 RED FLASHES</p> <p>3 RED FLASHES</p> <p>4 RED FLASHES</p> <p>5 RED FLASHES</p> <p>6 RED FLASHES</p> <p>7 RED FLASHES</p> <p>8 RED FLASHES</p> <p>9 RED FLASHES</p> <p>10 RED FLASHES</p> <p>11 RED FLASHES</p> <p>12 RED FLASHES</p>	<p>Power off or open fuse</p> <p>Low flame sense current</p> <p>No G from thermostat with Y call</p> <p>Control failure</p> <p>Flame sensor with gas off</p> <p>Check pressure switch wiring</p> <p>Check pressure switch wiring, wiring, draft inducer</p> <p>Airflow problem</p> <p>Flame rollout</p> <p>Repeated pressure switch cycles</p> <p>Failed to light burners</p> <p>Loss of flame during call for heat</p> <p>Incorrect polarity OR don't have neutral</p> <p>Gas valve shorted "ON"</p> <p>Check blower motor/wiring</p> <p>Missing model ID plug or improperly connected</p>
---	---

*Refer to Installation Manual for more detailed information.*

#### NOTES:

1. ALL FIELD WIRING TO BE ACCOMPLISHED FOLLOWING CITY, LOCAL, AND/OR NATIONAL CODES IN EFFECT AT THE TIME OF INSTALLATION OF UNIT.
2. CAUTION: LABEL ALL WIRES PRIOR TO DISCONNECTION WHEN SERVICING CONTROLS. WIRING ERRORS CAN CAUSE IMPROPER AND DANGEROUS OPERATION. IF ANY OF THE WIRING, AS SUPPLIED WITH UNIT, MUST BE REMOVED, IT MUST BE REPLACED WITH TYPE 105 C 600 VOLT WIRE OR EQUIVALENT AND CLEARLY RENUMBERED FOR IDENTIFICATION. VERIFY PROPER OPERATION AFTER SERVICING.
3. FACTORY WIRED FOR 230 VOLT SUPPLY POWER. FOR 208 VOLT SUPPLY POWER, MOVE BLACK WIRES FROM THE 230 VOLT TAP TO THE 208 VOLT TAP ON THE TRANSFORMER.
4. MOTORS ARE INHERENTLY PROTECTED.
5. SEE UNIT NAMEPLATE FOR MAXIMUM FUSE AND/OR CIRCUIT BREAKER SIZE AND MINIMUM CIRCUIT AMPACITY.
6. SELECT INDOOR BLOWER SPEED TO REMAIN WITHIN THE TEMPERATURE RISE RANGE ON THE NAMEPLATE IN HEATING AND TO OBTAIN APPROXIMATELY 400 CFM/TON IN COOLING.

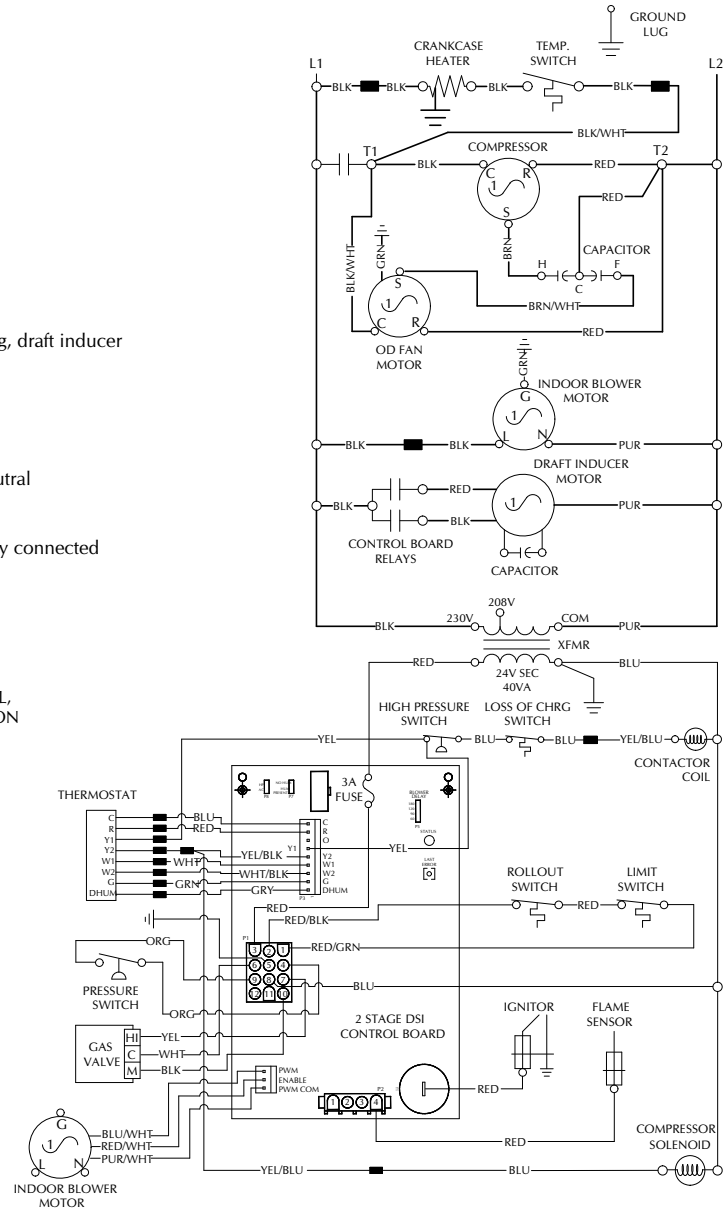

5202052-UWD-E-0519

**Figure 15:** Ladder Wiring Diagram

SECTION VIII: START UP SHEET

Residential Package Unit Cooling / Gas Heat Start-Up Sheet

Proper start-up is critical to customer comfort and equipment longevity

Start-Up Date <input style="width:80%;" type="text"/>	Company Name <input style="width:80%;" type="text"/>	Start-Up Technician <input style="width:80%;" type="text"/>
---	--	---

**Owner Information**

Name <input style="width:80%;" type="text"/>	Address <input style="width:80%;" type="text"/>	Daytime Phone <input style="width:80%;" type="text"/>
City <input style="width:80%;" type="text"/>	State or Province <input style="width:80%;" type="text"/>	Zip or Postal Code <input style="width:80%;" type="text"/>

**Equipment Data**

Unit Model # <input style="width:80%;" type="text"/>	Unit Serial # <input style="width:80%;" type="text"/>
--	---

**General Information** (Check all that apply)

<input type="radio"/> Residential	<input type="radio"/> New Construction	<input type="radio"/> Roof level	<input type="radio"/> Down flow
<input type="radio"/> Commercial	<input type="radio"/> Retrofit	<input type="radio"/> Grade level	<input type="radio"/> Side flow

**Unit Location and Connections** (Check all that apply)

<input type="checkbox"/> Unit is level and installed on:	<input type="checkbox"/> Slab	<input type="checkbox"/> Roof curb	<input type="checkbox"/> Duct connections are complete:	<input type="checkbox"/> Supply	<input type="checkbox"/> Return
<input type="checkbox"/> Condensate drain properly connected per the installation instructions		<input type="checkbox"/> Condensate trap has been primed with water			

**Filters**

<input type="checkbox"/> Filters installed	Number of filters <input style="width:40px;" type="text"/>	Filter size <input style="width:40px;" type="text"/>	<input type="radio"/> Filter located inside	<input type="radio"/> Filter located outside
--	--	--	---	--

**Additional Kits & Accessories Installed** (Check all that apply)

<input type="checkbox"/> Refrigerant safety kit	<input type="checkbox"/> Low ambient kit	<input type="checkbox"/> Anti-recycle timer	<input type="checkbox"/> Crank case heater	<input type="checkbox"/> Filter frame kit
<input type="checkbox"/> Transformer kit	<input type="checkbox"/> Economizer	<input type="checkbox"/> Roof curb kit	<input type="checkbox"/> Burglar bar kit	<input type="checkbox"/> Hail guard kit
<input type="checkbox"/> Manual fresh air damper kit		<input type="checkbox"/> Motorized fresh air damper kit		

**Electrical Connections & Inspection** (Check all that apply)

<input type="radio"/> Single phase	<input type="radio"/> Three phase	<input type="radio"/> 208 volts AC	<input type="radio"/> 230 volt AC	<input type="radio"/> 460 volts AC	<input type="radio"/> 575 volts AC
<input type="checkbox"/> Inspect wires and electrical connections		<input type="checkbox"/> Transformer wired properly for primary supply voltage		<input type="checkbox"/> Ground connected	
<input type="checkbox"/> Low voltage present at control board "R & C"		Measured voltage "R" and "C" outdoor unit control board		<input style="width:40px;" type="text"/>	
<input type="checkbox"/> Line voltage present at disconnect		Measured voltage "L1 to L2"	<input style="width:40px;" type="text"/>	"L2 to L3"	<input style="width:40px;" type="text"/>
Compressor amperes "L1"		<input style="width:40px;" type="text"/>	"L2"	<input style="width:40px;" type="text"/>	"L3"
Total amperes "L1"		<input style="width:40px;" type="text"/>	"L2"	<input style="width:40px;" type="text"/>	"L3"
<input type="radio"/> Single stage compressor		<input type="radio"/> Two stage compressor			

**Air Flow Setup / Cooling**

<b>Blower Type &amp; Set-Up</b>	<input type="radio"/> ECM	COOL	<input type="radio"/> A	<input type="radio"/> B	<input type="radio"/> C	<input type="radio"/> D
		ADJUST	<input type="radio"/> A	<input type="radio"/> B	<input type="radio"/> C	<input type="radio"/> D
		DELAY	<input type="radio"/> A	<input type="radio"/> B	<input type="radio"/> C	<input type="radio"/> D
	<input type="radio"/> X-13	<input type="radio"/> 1	<input type="radio"/> 2	<input type="radio"/> 3	<input type="radio"/> 4	<input type="radio"/> 5
	<input type="radio"/> PSC	<input type="radio"/> Low	<input type="radio"/> Medium Low	<input type="radio"/> Medium	<input type="radio"/> Medium High	<input type="radio"/> High

Supply static (inches of water column)	<input style="width:40px;" type="text"/>	Supply air dry bulb temperature	<input style="width:40px;" type="text"/>	Outside air dry bulb temperature	<input style="width:40px;" type="text"/>
Return static (inches of water column)	<input style="width:40px;" type="text"/>	Return air dry bulb temperature	<input style="width:40px;" type="text"/>	Return air wet bulb temperature	<input style="width:40px;" type="text"/>
Total external static pressure	<input style="width:40px;" type="text"/>	Temperature drop	<input style="width:40px;" type="text"/>	Supply air wet bulb temperature	<input style="width:40px;" type="text"/>

### Refrigerant Charge and Metering Device

<input type="radio"/> R-410A <input type="radio"/> R-22	Data plate - lbs / Oz <input type="text"/>	Suction line temperature <input type="text"/>	Discharge pressure <input type="text"/>
<input type="radio"/> TXV <input type="radio"/> Fixed Orifice	Discharge line temperature <input type="text"/>	Suction pressure <input type="text"/>	Liquid line temperature <input type="text"/>
TXV# / Orifice size <input type="text"/>		Superheat <input type="text"/>	Subcooling <input type="text"/>

### Gas Heat

<input type="radio"/> Single Stage <input type="radio"/> Two Stage	<input type="radio"/> Natural Gas <input type="radio"/> Propane LP (Requires LP Conversion Kit)
LP Gas Conversion Kit # <input type="text"/>	LP Conversion Kit Installed By <input type="text"/>
Inlet Gas Pressure (w.c.) <input type="text"/>	
Manifold Pressure at 100% Firing Rate (w.c.) <input type="text"/>	Measured BTU/H (Clock Gas Meter Nat Gas) <input type="text"/>
Rated BTU/H <input type="text"/>	
Manifold Pressure / Low Fire Rate (w.c.) <input type="text"/>	Return Air Dry Bulb Temp <input type="text"/>
Supply Air Dry Bulb Temp <input type="text"/>	Temp Rise <input type="text"/>
<input type="checkbox"/> Burner Flame Inspection - Blue flames extending directly into the primary heat exchanger cells	

### Clean Up Job Site

<input type="checkbox"/> Job site has been cleaned, indoor and outdoor debris removed from job site
<input type="checkbox"/> Tools have been removed from unit
<input type="checkbox"/> All panels have been installed

### Unit Operation and Cycle Test

<input type="checkbox"/> Operate the unit through continuous fan cycles from the thermostat, noting and correcting any problems
<input type="checkbox"/> Operate the unit through cooling cycles from the thermostat, noting and correcting any problems

### Owner Education

<input type="checkbox"/> Provide owner with the owner's manual
<input type="checkbox"/> Explain operation of system to equipment owner
<input type="checkbox"/> Explain thermostat use and programming (if applicable) to owner
<input type="checkbox"/> Explain the importance of regular filter replacement and equipment maintenance

### Comments and Additional Job Details