

# INSTALLATION MANUAL

**TWO STAGE STANDARD ECM  
RESIDENTIAL GAS FURNACE**  
**MODELS: TM8Y**  
**80% AFUE Multi-position / Low NOx**



## LIST OF SECTIONS

<b>SAFETY</b> .....	<b>1</b>	<b>START-UP AND ADJUSTMENTS</b> .....	<b>16</b>
<b>DUCTWORK</b> .....	<b>4</b>	<b>SAFETY CONTROLS</b> .....	<b>22</b>
<b>FILTERS</b> .....	<b>8</b>	<b>REPLACEMENT PARTS LIST</b> .....	<b>24</b>
<b>GAS PIPING</b> .....	<b>9</b>	<b>REPLACEMENT PART CONTACT INFORMATION</b> .....	<b>24</b>
<b>ELECTRICAL POWER</b> .....	<b>10</b>	<b>WIRING DIAGRAM</b> .....	<b>25</b>
<b>TWINNING</b> .....	<b>13</b>	<b>START UP SHEET</b> .....	<b>27</b>
<b>VENTING</b> .....	<b>13</b>		

## LIST OF FIGURES

Duct Attachment .....	5	Thermostat Chart - Two Stage HP with Two Stage Standard ECM Furnace .....	12
Combustible Floor Base Accessory .....	5	Combustion Air Inducer .....	13
Furnace and Coil Attachment .....	6	Combustion Airflow Path Through The Furnace Casing to the Burner Compartment .....	14
Horizontal Application .....	6	Ambient Combustion Air .....	15
Typical Attic Installation .....	7	Gas Valve .....	19
Typical Suspended Furnace / Crawl Space Installation .....	7	Reading Gas Pressure .....	19
Dimensions .....	8	Furnace Control Board .....	20
Side Return Cutout Markings .....	8	Measuring External Duct Static .....	21
Gas Valve .....	9	Wiring Diagram .....	25
Gas Piping .....	9		
Electrical Wiring .....	11		
Thermostat Chart - Two Stage AC with Two Stage Standard ECM Furnaces .....	12		

## LIST OF TABLES

Unit Clearances to Combustibles (All Dimensions in Inches, and All Surfaces Identified with the Unit in an Upflow Configuration) . . .	4	Unconfined Space Minimum Area .....	14
Cabinet and Duct Dimensions .....	8	Free Area .....	14
Recommended Filter Sizes (High Velocity 600 FPM) .....	8	Gas Rate (CU FT/HR) .....	18
Nominal Manifold Pressure - High Fire .....	10	Inlet Gas Pressure Range .....	18
Nominal Manifold Pressure - Low Fire .....	10	Nominal Manifold Pressure .....	19
Ratings & Physical / Electrical Data .....	11	Default Blower Speeds .....	20
Estimated Free Area .....	14	Blower Performance CFM - Any Position (without filter) .....	21

These high efficiency, compact units employ induced combustion, reliable hot surface ignition and high heat transfer aluminized tubular heat exchangers. The units are factory shipped for installation in upflow or horizontal applications and may be converted for downflow applications.

These furnaces are designed for residential installation in a basement, closet, alcove, attic, recreation room or garage and are also ideal for commercial applications. All units are factory assembled, wired and tested to assure safe dependable and economical installation and operation.

These units are Category I listed and may be common vented with another gas appliance as allowed by the National Fuel Gas Code.

## SECTION I: SAFETY



This is a safety alert symbol. When you see this symbol on labels or in manuals, be alert to the potential for personal injury.

Understand and pay particular attention to the signal words **DANGER**, **WARNING**, or **CAUTION**.

**DANGER** indicates an **imminently** hazardous situation, which, if not avoided, **will result in death or serious injury**.

**WARNING** indicates a **potentially** hazardous situation, which, if not avoided, **could result in death or serious injury**.

**CAUTION** indicates a **potentially** hazardous situation, which, if not avoided **may result in minor or moderate injury**. It is also used to alert against unsafe practices and hazards involving only property damage.

**▲ WARNING**

Improper installation may create a condition where the operation of the product could cause personal injury or property damage. Improper installation, adjustment, alteration, service or maintenance can cause injury or property damage. **Failure to carefully read and follow all instructions in this manual can result in furnace malfunction, death, personal injury and/or property damage.** Only a qualified contractor, installer or service agency should install this product.

## SPECIFIC SAFETY RULES AND PRECAUTIONS

1. Only Natural gas or Propane (LP) gas are approved for use with this furnace.
2. Install this furnace only in a location and position as specified in these instructions.
3. A gas-fired furnace for installation in a residential garage must be installed as specified in these instructions.
4. Provide adequate combustion and ventilation air to the furnace space as specified in these instructions.
5. Combustion products must be discharged outdoors. Connect this furnace to an approved vent system only, as specified in SECTION VII of these instructions.
6. Test for gas leaks as specified in these instructions.

## ⚠ WARNING

### FIRE OR EXPLOSION HAZARD

Failure to follow the safety warnings exactly could result in serious injury, death or property damage.

Never test for gas leaks with an open flame. Use a commercially available soap solution made specifically for detection of leaks to check all connections. A fire or explosion may result causing property damage, personal injury or loss of life.

7. Always install the furnace to operate within the furnace's intended temperature rise range. Only connect the furnace to a duct system which has an external static pressure within the allowable range, as specified on the furnace rating plate.
8. When a furnace is installed so that supply ducts carry air circulated by the furnace to areas outside the space containing the furnace, the return air shall also be handled by duct(s) sealed to the furnace casing and terminating outside the space containing the furnace.
9. It is permitted to use the furnace for heating of buildings or structures under construction where the application and use must comply with all manufacturer's installation instructions including:
  - Proper vent installation;
  - Furnace operating under thermostatic control;
  - Return air duct sealed to the furnace;
  - Air filters in place;
  - Set furnace input rate and temperature rise per rating plate marking;
  - Means for providing outdoor air required for combustion;
  - Return air temperature maintained between 55° F (13° C) and 80° F (27° C);
  - The **air filter must be replaced** upon substantial completion of the construction process;
  - Clean furnace, duct work and components upon substantial completion of the construction process, and verify furnace-operating conditions including ignition, input rate, temperature rise and venting, according to the manufacturer's instructions.
10. When installed in a Non-HUD-Approved Modular Home or building constructed on-site, combustion air shall not be supplied from occupied spaces.
11. The size of the unit should be based on an acceptable heat loss calculation for the structure. ACCA, Manual J or other approved methods may be used.
12. When moving or handling this furnace prior to installation it is recommended to leave the doors on the furnace to provide support and to prevent damage or warping of the cabinet. When lifting the furnace by the cabinet, support the ends of the furnace rather than lifting by the cabinet flanges at the return air openings (bottom or sides) or supply air opening.
13. When lifting the furnace, it is acceptable to use the primary heat exchanger tubes as a lifting point provided that the tubes are lifted at the front of the heat exchangers where attached to the vestibule panel. Do not use the top return bend of the heat exchangers as lifting points as the tubes may shift out of position or their location brackets/baffles.

**IMPORTANT: During installation, doors should remain on the furnace when moving or lifting.**

## SAFETY REQUIREMENTS

## ⚠ CAUTION

This product must be installed in strict compliance with the installation instructions and any applicable local, state, and national codes including, but not limited to building, electrical, and mechanical codes.

- Refer to the unit rating plate for the furnace model number, and then see the dimensions page of this instruction for return air plenum dimensions in Figure 6. The plenum must be installed according to the instructions.
- Provide clearances from combustible materials as listed under Clearances to Combustibles.
- Provide clearances for servicing ensuring that service access is allowed for both the burners and blower.
- These models **ARE NOT** CSA listed or approved for installation into a **HUD Approved Modular Home** or a **Manufactured (Mobile) Home**.
- This furnace is not approved for installation in trailers or recreational vehicles.
- Furnaces for installation on combustible flooring shall not be installed directly on carpeting, tile or other combustible material other than wood flooring.
- Check the rating plate and power supply to be sure that the electrical characteristics match. All models use nominal 115 VAC, 1 Phase, 60-Hertz power supply. **DO NOT CONNECT THIS APPLIANCE TO A 50 HZ POWER SUPPLY OR A VOLTAGE ABOVE 130 VOLTS.**
- Furnace shall be installed so the electrical components are protected from water.
- Installing and servicing heating equipment can be hazardous due to the electrical components and the gas fired components. Only trained and licensed personnel should install, repair, or service gas heating equipment. Unlicensed service personnel can perform basic maintenance functions such as cleaning and replacing the air filters. When working on heating equipment, observe precautions in the manuals and on the labels attached to the unit and other safety precautions that may apply.

### COMBUSTION AIR QUALITY (LIST OF CONTAMINANTS)

## ⚠ WARNING

The furnace area must not be used as a broom closet or for any other storage purposes, as a fire hazard may be created. Never store items such as the following on, near or in contact with the furnace.

1. Spray or aerosol cans, rags, brooms, dust mops, vacuum cleaners or other cleaning tools.
2. Soap powders, bleaches, waxes or other cleaning compounds; plastic items or containers; gasoline, kerosene, cigarette lighter fluid, dry cleaning fluids or other volatile fluid.
3. Paint thinners and other painting compounds.
4. Paper bags, boxes or other paper products

**Never operate the furnace with the blower door removed. To do so could result in serious personal injury and/or equipment damage.**

The furnace requires **OUTDOOR AIR** for combustion when the furnace is located in any of the following environments.

- Restricted Environments
- Commercial buildings
- Buildings with indoor pools
- Furnaces installed in laundry rooms
- Furnaces installed in hobby or craft rooms
- Furnaces installed near chemical storage areas
- Chemical exposure

The furnace requires **OUTDOOR AIR** for combustion when the furnace is located in an area where the furnace is being exposed to the following substances and / or chemicals.

- Permanent wave solutions
- Chlorinated waxes and cleaners
- Chlorine based swimming pool chemicals
- Water softening chemicals
- De-icing salts or chemicals
- Carbon tetrachloride
- Halogen type refrigerants
- Cleaning solvents (such as perchloroethylene)
- Printing inks, paint removers, varnishes, etc.
- Hydrochloric acid
- Cements and glues
- Antistatic fabric softeners for clothes dryers
- Masonry acid washing materials

When outdoor air is used for combustion, the combustion air intake duct system termination must be located external to the building and in an area where there will be no exposure to the substances listed above.

## CODES AND STANDARDS

Follow all national, local codes and standards in addition to this installation manual. The installation must comply with regulations of the serving gas supplier, local building, heating, plumbing, and other codes. In absence of local codes, the installation must comply with the national codes listed below and all authorities having jurisdiction.

In the United States and Canada, follow all codes and standards for the following, using the latest edition available:

### STEP 1 -Safety

- US: National Fuel Gas Code (NFGC) NFPA 54/ANSI Z223.1 and the Installation Standards, Warm Air Heating and Air Conditioning Systems ANSI/NFPA 90B
- CANADA: CAN/CGA-B149.1 National Standard of Canada. Natural Gas and Propane Installation Codes (NSCNGPIC)

### STEP 2 -General Installation

- US: Current edition of the NFGC and NFPA 90B. For copies, contact the  
National Fire Protection Association Inc.  
Batterymarch Park  
Quincy, MA 02269
- or for only the NFGC, contact the  
American Gas Association,  
400 N. Capital, N.W.  
Washington DC 20001
- or www.NFPA.org
- CANADA: NSCNGPIC. For a copy contact:  
Standard Sales, CSA International  
178 Rexdale Boulevard  
Etobicoke, (Toronto) Ontario Canada M9W 1R5

### STEP 3 -Combustion and Ventilation Air

- US: Section 5.3 of the NFGC, air for Combustion and Ventilation
- CANADA: Part 7 of NSCNGPIC, Venting Systems and Air Supply for Appliances

### STEP 4 -Duct Systems

- US and CANADA: Air Conditioning Contractors Association (ACCA) Manual D, Sheet Metal and Air Conditioning Contractors Association National Association (SMACNA), or American Society of Heating, Refrigeration, and Air Conditioning Engineers (ASHRAE) 1997 Fundamentals Handbook Chapter 32.

### STEP 5 -Acoustical Lining and Fibrous Glass Duct

- US and CANADA: Current edition of SMACNA and NFPA 90B as tested by UL Standard 181 for Class I Rigid Air Ducts

### STEP 6 -Gas Piping and Gas Pipe Pressure Testing

- US: NFGC; chapters 2, 3, 4, & 9 and National Plumbing Codes
- CANADA: NSCNGPIC Part 5

### STEP 7 -Electrical Connections

- US: National Electrical Code (NEC) ANSI/NFPA 70
- CANADA: Canadian Electrical Code CSA C22.1

These instructions cover minimum requirements and conform to existing national standards and safety codes. In some instances these instructions exceed certain local codes and ordinances, especially those who have not kept up with changing residential and non-HUD modular home construction practices. These instructions are required as a minimum for a safe installation.

## FOR FURNACES INSTALLED IN THE COMMON-WEALTH OF MASSACHUSETTS ONLY

For all side wall horizontally vented gas fueled equipment installed in every dwelling, building or structure used in whole or in part for residential purposes, including those owned or operated by the Commonwealth and where the side wall exhaust vent termination is less than seven (7) feet above finished grade in the area of the venting, including but not limited to decks and porches, the following requirements shall be satisfied:

1. **INSTALLATION OF CARBON MONOXIDE DETECTORS.** At the time of installation of the side wall horizontal vented gas fueled equipment, the installing plumber or gasfitter shall observe that a hard wired carbon monoxide detector with an alarm and battery back-up is installed on the floor level where the gas equipment is to be installed. In addition, the installing plumber or gasfitter shall observe that a battery operated or hard wired carbon monoxide detector with an alarm is installed on each additional level of the dwelling, building or structure served by the side wall horizontal vented gas fueled equipment. It shall be the responsibility of the property owner to secure the services of qualified licensed professionals for the installation of hard wired carbon monoxide detectors.
  - a. In the event that the side wall horizontally vented gas fueled equipment is installed in a crawl space or an attic, the hard wired carbon monoxide detector with alarm and battery back-up may be installed on the next adjacent floor level.
  - b. In the event that the requirements of this subdivision can not be met at the time of completion of installation, the owner shall have a period of thirty (30) days to comply with the above requirements; provided, however, that during said thirty (30) day period, a battery operated carbon monoxide detector with an alarm shall be installed.
2. **APPROVED CARBON MONOXIDE DETECTORS.** Each carbon monoxide detector as required in accordance with the above provisions shall comply with NFPA 720 and be ANSI/UL 2034 listed and IAS certified.
3. **SIGNAGE.** A metal or plastic identification plate shall be permanently mounted to the exterior of the building at a minimum height of eight (8) feet above grade directly in line with the exhaust vent terminal for the horizontally vented gas fueled heating appliance or equipment. The sign shall read, in print size no less than one-half (1/2) inch in size, "**GAS VENT DIRECTLY BELOW. KEEP CLEAR OF ALL OBSTRUCTIONS**".
4. **INSPECTION.** The state or local gas inspector of the side wall horizontally vented gas fueled equipment shall not approve the installation unless, upon inspection, the inspector observes carbon monoxide detectors and signage installed in accordance with the provisions of 248 CMR 5.08(2)(a)1 through 4.

## INSPECTION

As soon as a unit is received, it should be inspected for possible damage during transit. If damage is evident, the extent of the damage should be noted on the carrier's freight bill. A separate request for inspection by the carrier's agent should be made in writing. Before installation, the unit should be checked for screws or bolts which may have loosened in transit. There are no shipping or spacer brackets which need to be removed from the interior of this unit.

## FURNACE LOCATION AND CLEARANCES

### The furnace shall be located using the following guidelines:

1. Where a minimum amount of air intake/vent piping and elbows will be required.
2. As centralized with the air distribution as possible.
3. Where adequate combustion air will be available (particularly when the appliance is not using outdoor combustion air).
4. Where it will not interfere with proper air circulation in the confined space.

### Installation in freezing temperatures:

1. Furnace shall be installed in an area where ventilation facilities provide for safe limits of ambient temperature under normal operating conditions.

## ⚠ WARNING

Improper installation in an ambient below 32° F (0° C) could create a hazard, resulting in damage, injury or death.

2. Do not allow return air temperature to be below 55° F (13° C) for extended periods. To do so may cause condensation to occur in the main heat exchanger, leading to premature heat exchanger failure.

### Clearances for access/service:

Ample clearances should be provided to permit easy access to the unit. The following minimum clearances are recommended:

1. Twenty-four (24) inches (61 cm) between the front of the furnace and an adjacent wall or another appliance, when access is required for servicing and cleaning.
2. Eighteen (18) inches (46 cm) at the side where access is required for passage to the front when servicing or for inspection or replacement of flue/vent connections.

In all cases, accessibility clearances shall take precedence over clearances for combustible materials where accessibility clearances are greater.

### Installation in a residential garage:

A gas-fired furnace for installation in a residential garage must be installed so the burner(s) and the ignition source are located not less than 18 inches (46 cm) above the floor, and the furnace must be located or protected to avoid physical damage by vehicles.

**Table 1:** Unit Clearances to Combustibles (All Dimensions in Inches, and All Surfaces Identified with the Unit in an Upflow Configuration)

Application	Top	Front	Rear	Left Side	Right Side	Flue	Floor/ Bottom	Closet	Alcove	Attic	Line Contact
	In. (cm)	In. (cm)	In. (cm)	In. (cm)	In. (cm)	In. (cm)					
Upflow	1 (2.5)	1 (2.5)	0 (0.0)	0 (0.0)	0 (0.0)	6 (15.2)	Combustible	Yes	Yes	Yes	No
Upflow B-Vent	1 (2.5)	1 (2.5)	0 (0.0)	0 (0.0)	0 (0.0)	1 (2.5)	Combustible	Yes	Yes	Yes	No
Downflow	1 (2.5)	1 (2.5)	0 (0.0)	0 (0.0)	0 (0.0)	6 (15.2)	1 (25.4) <sup>1</sup>	Yes	Yes	Yes	No
Downflow B-Vent	1 (2.5)	1 (2.5)	0 (0.0)	0 (0.0)	0 (0.0)	1 (2.5)	1 (25.4) <sup>1</sup>	Yes	Yes	Yes	No
Horizontal	1 (2.5)	1 (2.5)	0 (0.0)	0 (0.0)	0 (0.0)	6 (15.2)	Combustible	No	Yes	Yes	Yes <sup>2</sup>
Horizontal B-Vent	1 (2.5)	1 (2.5)	0 (0.0)	0 (0.0)	0 (0.0)	1 (2.5)	Combustible	No	Yes	Yes	Yes <sup>2</sup>

1. Combustion floor base accessory or air conditioning coil required for use on combustible floor.

2. Line contact only permitted between lines formed by the intersection of the rear panel and side panel (top in horizontal position) of the furnace jacket and building joists, studs or framing.

## SECTION II: DUCTWORK

### DUCTWORK GENERAL INFORMATION

#### **The duct system's design and installation must:**

1. Handle an air volume appropriate for the served space and within the operating parameters of the furnace specifications.
2. Be installed in accordance of National Fire Protection Association as outlined in NFPA standard 90B (latest editions) or applicable national, provincial, state, and local fire and safety codes.
3. Create a closed duct system. For residential and Non-HUD Modular Home installations, when a furnace is installed so that the supply ducts carry air circulated by the furnace to areas outside the space containing the furnace, the return air shall also be handled by a duct(s) sealed to the furnace casing and terminating outside the space containing the furnace.
4. Complete a path for heated or cooled air to circulate through the air conditioning and heating equipment and to and from the conditioned space.

## ⚠ CAUTION

The indoor coil must be installed in the supply air duct, downstream of the furnace. Cooled air may not be passed over the heat exchanger.

When the furnace is used with an indoor coil, the coil must be installed parallel with, or in the supply air side of the furnace to avoid condensation in the primary heat exchanger. When a parallel flow arrangement is used, dampers or other means used to control airflow must be adequate to prevent chilled air from entering the furnace. If manually operated, the damper must be equipped with means to prevent the furnace or the air conditioner from operating unless the damper is in full heat or cool position.

When replacing an existing furnace, if the existing plenum is not the same size as the new furnace then the existing plenum must be removed and a new plenum installed that is the proper size for the new furnace. If the plenum is shorter than 12" (30.5 cm) the turbulent air flow may cause the limit controls not to operate as designed, or the limit controls may not operate at all.

The duct system is a very important part of the installation. **If the duct system is improperly sized the furnace will not operate properly.** The ducts attached to the furnace plenum, should be of sufficient size so that the furnace operates at the specified external static pressure and within the air temperature rise specified on the nameplate.

**IMPORTANT:** The minimum plenum height is 12" (30.5 cm). The furnace will not operate properly on a shorter plenum height. The minimum recommended rectangular duct height is 4 inches (10 cm) attached to the plenum.

## ⚠ WARNING

The duct system must be properly sized to obtain the correct airflow for the furnace size that is being installed.

Refer to Table 6 or the furnace rating plate for the correct rise range and static pressures.

If the ducts are undersized, the result will be high duct static pressures and/or high temperature rises which can result in a heat exchanger **OVERHEATING CONDITION**. This condition can result in premature heat exchanger failure, which can result in personal injury, property damage, or death.

If a matching indoor coil is used, it may be placed directly on the furnace outlet and sealed to prevent leakage. If thermoplastic indoor coil drain pans are to be installed in the upflow/horizontal configuration, then extra 2" minimum spacing may be needed to ensure against drain pan distortion.

On all installations without a coil, a removable access panel is recommended in the outlet duct such that smoke or reflected light would be observable inside the casing to indicate the presence of leaks in the heat exchanger. This access cover shall be attached in such a manner as to prevent leaks.

### DUCT FLANGES

Four flanges are provided to attach ductwork to the furnace. These flanges are rotated down for shipment. In order to use the flanges, remove the screw holding an individual flange, rotate the flange so it is in the upward position and reinstall the screw then repeat this for all 4 flanges.

If the flanges are not used, they must remain in the rotated down position as shipped.

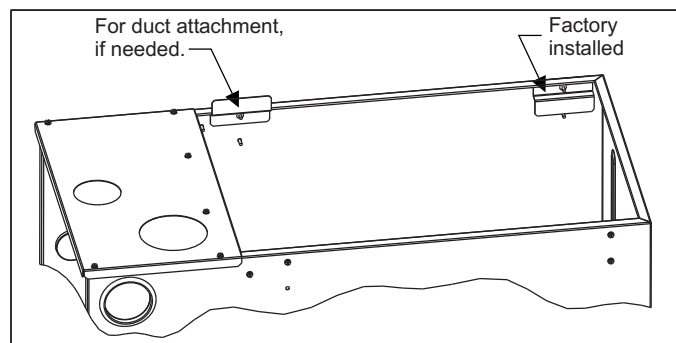

FIGURE 1: Duct Attachment

### DUCTWORK INSTALLATION AND SUPPLY PLENUM CONNECTION - UPFLOW/HORIZONTAL



Attach the supply plenum to the furnace outlet. The use of an approved flexible duct connector is recommended on all installations. This connection should be sealed to prevent air leakage. The sheet metal should be crosshatched to eliminate any popping of the sheet metal when the indoor fan is energized.

### FLOOR BASE AND DUCTWORK INSTALLATION - DOWNFLOW



Installations on combustible material or directly on any floors must use a combustible floor base shown in Figure 2. Follow the instructions supplied with the combustible floor base accessory. This combustible floor base can be replaced with a matching cooling coil, properly sealed to prevent leaks. Follow the instructions supplied with the cooling coil cabinet for installing the cabinet to the duct connector. Plug intake and vent pipe holes in bottom panel and move grommet to desired vent side exit.

### Downflow Air Conditioning Coil Cabinet

The furnace should be installed with coil cabinet part number specifically intended for downflow application. If a matching cooling coil is used, it may be placed directly on the furnace outlet and sealed to prevent leakage. For details of the coil cabinet dimensions and installation requirements, refer to the installation instructions supplied with the coil cabinet.

Attach the air conditioning coil cabinet to the duct connector, and then position the furnace on top of the coil cabinet. The connection to the furnace, air conditioning coil cabinet, duct connector, and supply air duct must be sealed to prevent air leakage.

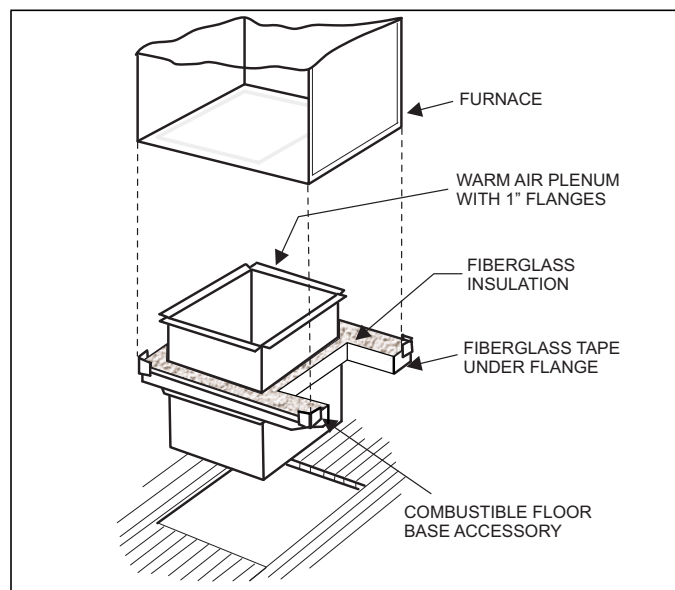
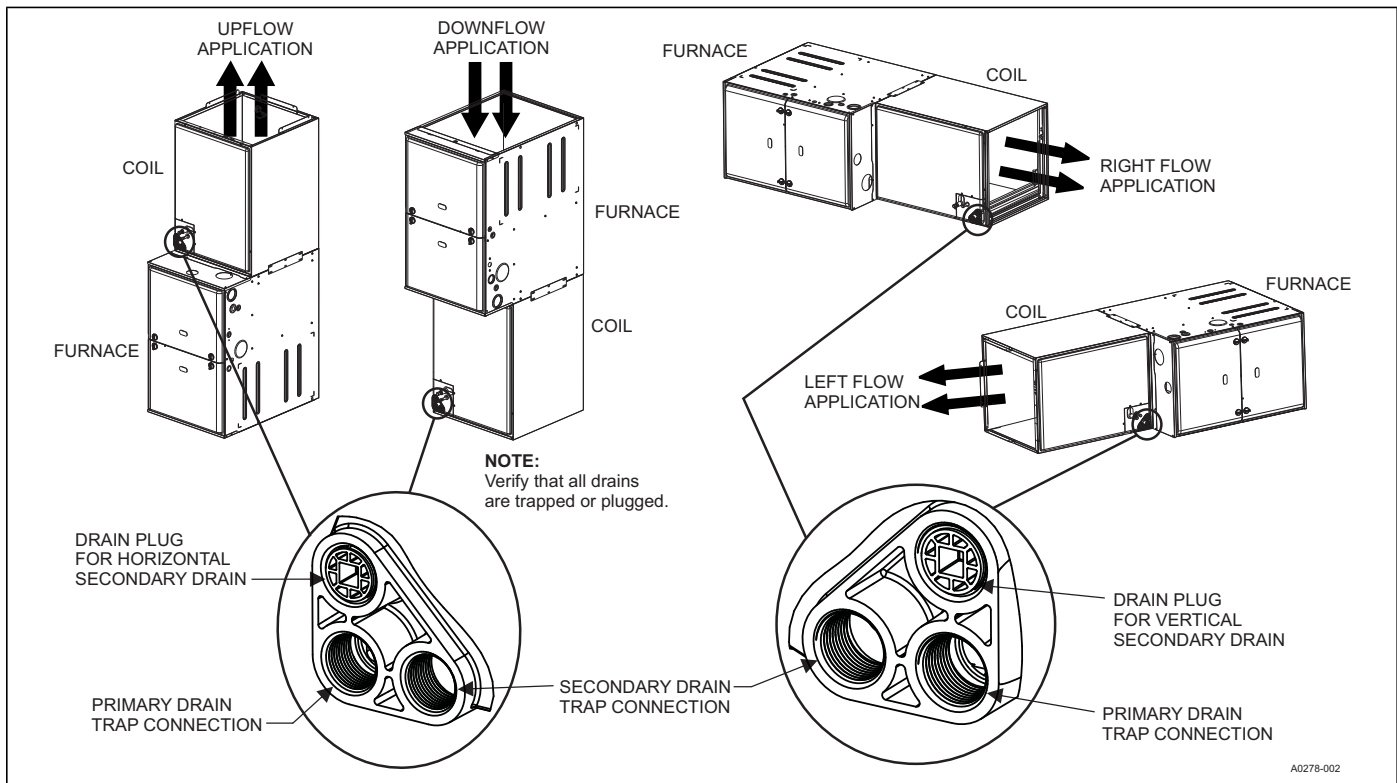

FIGURE 2: Combustible Floor Base Accessory

### COIL INSTALLATION

**IMPORTANT:** On all installations without a coil, a removable access panel is recommended in the outlet duct such that smoke or reflected light would be observable inside the casing to indicate the presence of leaks in the heat exchanger. This access cover shall be attached in such a manner as to prevent leaks.

The indoor coil must be mounted on the supply side of the furnace as shown in Figure 3. Refer to the Installation Instructions provided with each indoor coil.



**FIGURE 3:** Furnace and Coil Attachment

#### RESIDENTIAL AND MODULAR HOME UPFLOW RETURN PLENUM CONNECTION

Return air may enter the furnace through the side(s) or bottom depending on the type of application. Return air may not be connected into the rear panel of the unit.

#### SIDE RETURN APPLICATION

Side return applications pull return air through an opening cut in the side of the furnace casing. This furnace is supplied with a bottom block-off panel that should be left in place if a side return is to be used. If the furnace is to be installed on a flat, solid surface, this bottom panel will provide an adequate seal to prevent air leakage through the unused bottom opening. However, if the furnace is to be installed on a surface that is uneven, or if it is to be installed on blocks or otherwise raised off the floor, **it will be necessary to seal the edges of the bottom panel to the casing using tape or other appropriate gasket material to prevent air leakage.**

#### BOTTOM RETURN AND ATTIC INSTALLATIONS

Bottom return applications normally pull return air through a base platform or return air plenum. Be sure the return platform structure or return air plenum is suitable to support the weight of the furnace.

The internal bottom panel must be removed for this application.

Attic installations must meet all minimum clearances to combustibles and have floor support with required service accessibility.

#### DOWNFLOW APPLICATION

For downflow applications, the furnace must be turned upside-down so that the circulating air enters at the top and exits the furnace at the bottom. The combustion air blower must be rotated 90° as shown in Figure 14. **DO NOT BLOCK COMBUSTION AIR INLET OPENINGS.**

#### HORIZONTAL APPLICATION

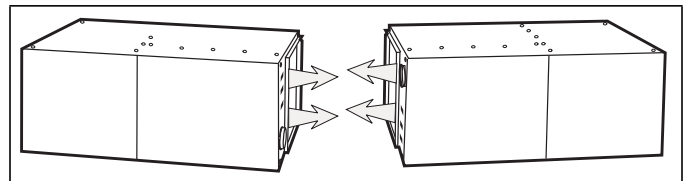

**FIGURE 4:** Horizontal Application

**IMPORTANT:** This furnace may be installed in a horizontal position on either side as shown above. **It must not be installed on its back.**

## ATTIC INSTALLATION

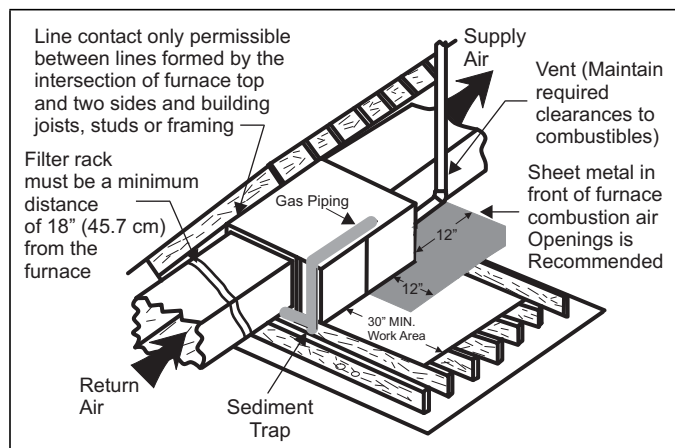

FIGURE 5: Typical Attic Installation

This appliance is certified for line contact when the furnace is installed in the horizontal left or right position. The line contact is only permissible between lines that are formed by the intersection of the top and two sides of the furnace and the building joists, studs or framing. This line may be in contact with combustible material. Refer to Figure 5.

### ⚠ WARNING

When a furnace is installed in an attic or other insulated space, keep all insulating materials at least 12 inches (30.5 cm) away from furnace and burner combustion air openings.

**IMPORTANT: During installation, doors should remain on the furnace when moving or lifting.**

When moving or handling this furnace prior to installation, always leave the doors on the furnace to provide support and to prevent damage or warping of the cabinet. When lifting the furnace, support the ends of the furnace rather than lifting by the cabinet flanges at the return air openings (bottom or sides) or supply air opening.

It is acceptable to use the primary heat exchanger tubes as a lifting point provided that the tubes are lifted at the front of the heat exchangers where attached to the vestibule panel. Do not use the top return bend of the heat exchangers as lifting points as the tubes may shift out of position or their location brackets/baffles.

## SUSPENDED FURNACE / CRAWL SPACE INSTALLATION

The furnace can be hung from floor joists or installed on suitable blocks or pads. Blocks or pad installations shall provide adequate height to ensure that the unit will not be subject to water damage.

Units may also be suspended from rafters or floor joists using rods, pipe angle supports or straps. In all cases, the furnace should be supported with rods, straps, or angle supports at three locations to properly support the furnace. Place one support at the supply end of the furnace, one support located approximately in the center of the furnace near the blower shelf, and the third support should be at the return end of the furnace. Maintain a 6" (15.2 cm) minimum clearance between the front of the furnace and the support rods or straps.

All six suspension points must be level to ensure proper and quiet furnace operation. When suspending the furnace, use a secure platform constructed of plywood or other building materials secured to the floor or ceiling joists. Refer to Figure 6 for details and additional information.

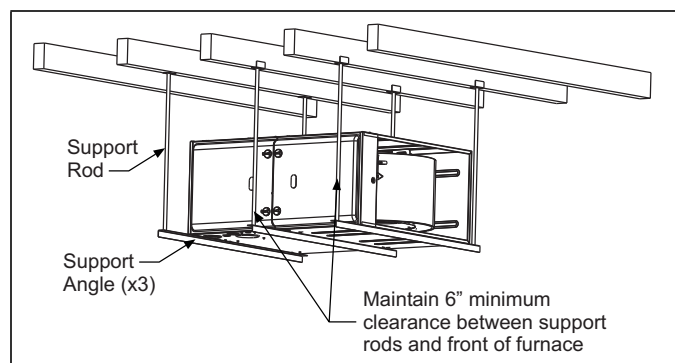

FIGURE 6: Typical Suspended Furnace / Crawl Space Installation

**IMPORTANT: During installation, doors should remain on the furnace when moving or lifting.**

When moving or handling this furnace prior to installation it is recommended to leave the doors on the furnace to provide support and to prevent damage or warping of the cabinet. When lifting the furnace, support the ends of the furnace rather than lifting by the cabinet flanges at the return air openings (bottom or sides) or supply air opening.

It is acceptable to use the primary heat exchanger tubes as a lifting point provided that the tubes are lifted at the front of the heat exchangers where attached to the vestibule panel. Do not use the top return bend of the heat exchangers as lifting points as the tubes may shift out of position or their location brackets/baffles.

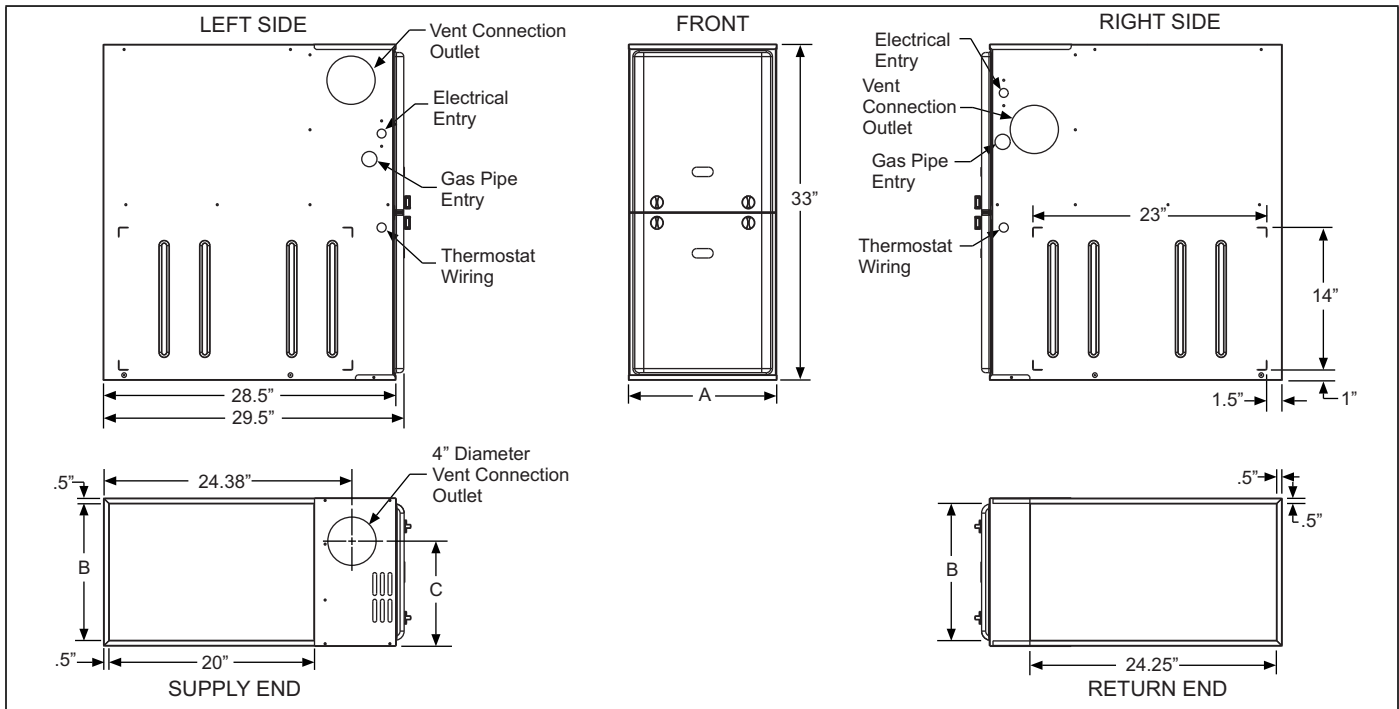

FIGURE 7: Dimensions

Table 2: Cabinet and Duct Dimensions

BTUH (kW) Input	Nominal CFM (m <sup>3</sup> /min)	Cabinet Size	Cabinet Dimensions (Inches)					
			A	A (cm)	B	B (cm)	C	C (cm)
60 (17.6)	1200 (34.0)	A	14 1/2	36.8	13 3/8	34.0	10.3	26.2
80 (23.4)	1200 (34.0)	B	17 1/2	44.4	16 3/8	41.6	11.8	29.9
80 (23.4)	1600 (45.3)	C	21	53.3	19 7/8	50.5	13.6	34.5
100 (29.3)	1600 (45.3)	C	21	53.3	19 7/8	50.5	13.6	34.5
100 (29.3)	2000 (56.6)	C	21	53.3	19 7/8	50.5	13.6	34.5
120 (35.1)	2000 (56.6)	C	21	53.3	19 7/8	50.5	13.6	34.5

SECTION III: FILTERS

FILTER INSTALLATION

**CAUTION**

All filters and mounting provision must be field supplied. All installations must have a filter installed.

All applications require the use of a field installed filter. All filters and mounting provision must be field supplied.

Filters must be installed external to the furnace cabinet. **DO NOT attempt to install filters inside the furnace.**

**NOTICE**

Single side return above 1800 CFM is approved as long as the filter velocity does not exceed filter manufacturer's recommendation.

Table 3: Recommended Filter Sizes (High Velocity 600 FPM)

CFM (m <sup>3</sup> /min)	Cabinet Size	Side (in)	Bottom (in)
1200 (34.0)	A	16 x 25	14 x 25
1200 (34.0)	B	16 x 25	16 x 25
1600 (45.3)	C	16 x 25	20 x 25
2000 (56.6)	C	(2) 16 x 25	20 x 25

- Air velocity through throwaway type filters may not exceed 300 feet per minute (91.4 m/min). All velocities over this require the use of high velocity filters.
- Do not exceed 1800 CFM using a single side return and a 16x25 filter. For CFM greater than 1800, you may use two side returns or one side and the bottom or one return with a transition to allow use of a 20x25 filter.

SIDE RETURN

Locate the "L" shaped corner locator's. These indicate the size of the cutout to be made in the furnace side panel. Refer to Figure 8.

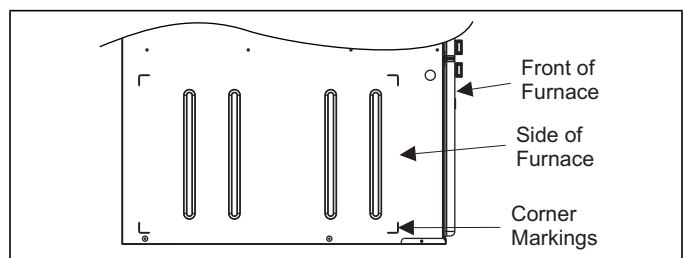

FIGURE 8: Side Return Cutout Markings

Install the side filter rack following the instructions provided with that accessory. If a filter(s) is provided at another location in the return air system, the ductwork may be directly attached to the furnace side panel.

**IMPORTANT:** Some accessories such as electronic air cleaners and pleated media may require a larger side opening. Follow the instructions supplied with that accessory for side opening requirements. Do not cut the opening larger than the dimensions shown in Figure 7.



## HORIZONTAL FILTERS

Any branch duct (rectangular or round duct) attached to the plenum must attach to the vertical plenum before the filter. The use of straps and / or supports is required to support the weight of the external filter box.

## DOWNFLOW FILTERS

### ⚠ CAUTION

In downflow furnace arrangement, the filter must be located a minimum of 12" from the return air inlet of furnace.

Downflow furnaces typically are installed with the filters located above the furnace, extending into the return air plenum or duct. Any branch duct (rectangular or round duct) attached to the plenum must attach to the vertical plenum above the filter height.

Filter(s) may be located in the duct system external to the furnace using an external duct filter box attached to the furnace plenum or at the end of the duct in a return filter grille(s). The use of straps and/or supports is required to support the weight of the external filter box.

## SECTION IV: GAS PIPING

### GAS SAFETY

### ⚠ DANGER

An overpressure protection device, such as a pressure regulator, must be installed in the gas piping system upstream of the furnace and must act to limit the downstream pressure to the gas valve so it does not exceed 0.5 PSI (14" w.c., 3.48 kPa). Pressures exceeding 0.5 PSI (14" w.c., 3.48 kPa) at the gas valve will cause damage to the gas valve, resulting in a fire or explosion or cause damage to the furnace or some of its components that will result in property damage and loss of life.

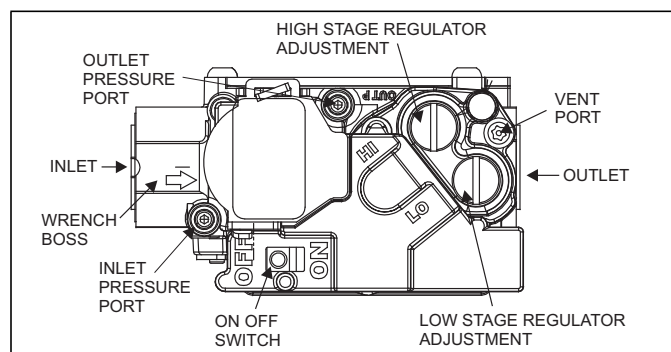

FIGURE 9: Gas Valve

**IMPORTANT:** Plan your gas supply before determining the correct gas pipe entry. Use 90-degree service elbow(s), or short nipples and conventional 90-degree elbow(s) to enter through the cabinet access holes.

## GAS PIPING INSTALLATION

Properly sized wrought iron, approved flexible or steel pipe must be used when making gas connections to the unit. If local codes allow the use of a flexible gas appliance connection, always use a new listed connector. Do not use a connector that has previously serviced another gas appliance.

Some utility companies or local codes require pipe sizes larger than the minimum sizes listed in these instructions and in the codes. The furnace rating plate and the instructions in this section specify the type of gas approved for this furnace - only use those approved gases. The installation of a drip leg and ground union is required. Refer to Figure 10.

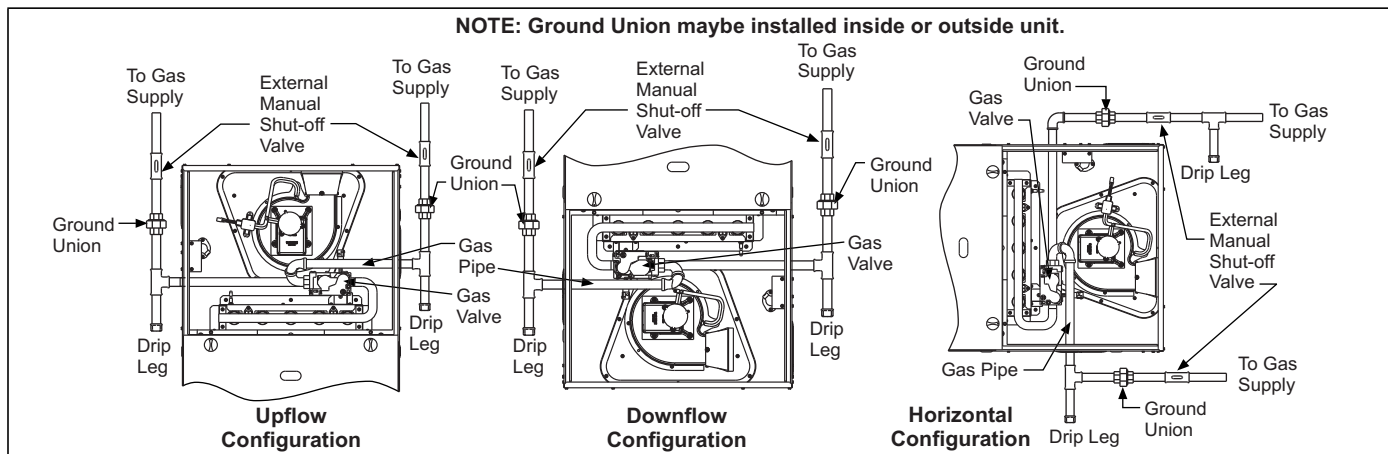

FIGURE 10: Gas Piping

**IMPORTANT:** An accessible manual shutoff valve must be installed upstream of the furnace gas controls and within 6 feet (1.8 m) of the furnace.

The furnace must be isolated from the gas supply piping system by closing its individual external manual shutoff valve during any pressure testing of the gas supply piping system at pressures equal to or less than 1/2 psig (3.5 kPa).

### ⚠ CAUTION

The gas valve body is a very thin casting that cannot take any external pressure. Never apply a pipe wrench to the body of the gas valve when installing piping. A wrench must be placed on the octagon hub located on the gas inlet side of the valve. Placing a wrench to the body of the gas valve will damage the valve causing improper operation and/or the valve to leak.

Gas piping may be connected from either side of the furnace using any of the gas pipe entry on both sides of the furnace. Refer to Figure 10.

## GAS ORIFICE CONVERSION FOR PROPANE (LP)

This furnace is constructed at the factory for natural gas-fired operation, but may be converted to operate on propane (LP) gas by using a factory-supplied LP conversion kit. Follow the instructions supplied with the LP kit.

## MANIFOLD PRESSURE ADJUSTMENT

High fire manifold pressure **MUST** be set before adjusting low fire.

### ⚠ WARNING

LoNOx furnaces requiring propane (LP) gas must have the LoNOx screens removed prior to installation and operation. See propane instructions.

## HIGH ALTITUDE MANIFOLD PRESSURE ADJUSTMENT

This furnace is constructed at the factory for natural gas-fired operation at 0–5,000 feet (0-m – 1,524 m) above sea level.

The manifold pressure must be changed in order to maintain proper and safe operation when the furnace is installed in a location where the altitude is greater than 5,000 feet (1,524 m) above sea level. Refer to

Tables 4 & 5 for proper manifold pressure settings. High fire manifold pressure must be set before adjusting low fire.

## HIGH ALTITUDE PRESSURE SWITCH CONVERSION

For installation where the altitude is less than 5,000 feet (1,524m), it is not required that the pressure switches be changed unless you are in an area subject to low pressure inversions.

**Table 4:** Nominal Manifold Pressure - High Fire

Manifold Pressures (in. w.c.)			
Gas Heating Value (BTU/cu ft.)	Altitude (feet)		
	0-7999	8000-8999	9000-9999
800	3.5	3.5	3.5
850	3.5	3.5	3.5
900	3.5	3.5	3.5
950	3.5	3.5	3.3
1000	3.5	3.2	2.9
1050	3.5	2.9	2.7
1100	3.2	2.7	2.4
2500 (LP)	9.8	8.2	7.5

Manifold Pressures (kPa)			
Gas Heating Value (MJ/cu m)	Altitude (m)		
	0-2437	2438-2742	2743-3048
29.8	0.9	0.9	0.9
31.7	0.9	0.9	0.9
33.5	0.9	0.9	0.9
35.4	0.9	0.9	0.8
37.3	0.9	0.8	0.7
39.1	0.9	0.7	0.7
41.0	0.8	0.7	0.6
93.2 (LP)	2.4	2.0	1.9

**TABLE 5:** Nominal Manifold Pressure - Low Fire

First Stage Manifold Pressures (in. w.c.)			
Gas Heating Value (BTU/cu ft.)	Altitude (feet)		
	0-7999	8000-8999	9000-9999
800	1.7	1.7	1.7
850	1.7	1.7	1.7
900	1.7	1.7	1.7
950	1.7	1.7	1.5
1000	1.6	1.5	1.4
1050	1.5	1.4	1.3
1100	1.3	1.2	1.1
2500 (LP)	4.1	3.8	3.5

First Stage Manifold Pressures (kPa)			
Gas Heating Value (MJ/cu m)	Altitude (m)		
	0-2437	2438-2742	2743-3048
29.8	0.4	0.4	0.4
31.7	0.4	0.4	0.4
33.5	0.4	0.4	0.4
35.4	0.4	0.4	0.4
37.3	0.4	0.4	0.3
39.1	0.4	0.4	0.3
41.0	0.3	0.3	0.3
93.2 (LP)	1.0	1.0	0.9

## ⚠ DANGER

### PROPANE AND HIGH ALTITUDE CONVERSION KITS

It is very important to choose the correct kit and/or gas orifices for the altitude and the type of gas for which the furnace is being installed.

Only use natural gas in furnaces designed for natural gas. Only use propane (LP) gas for furnaces that have been properly converted to use propane (LP) gas. Do not use this furnace with butane gas.

Incorrect gas orifices or a furnace that has been improperly converted will create an extremely dangerous condition resulting in premature heat exchanger failure, excessive sooting, high levels of carbon monoxide, personal injury, property damage, a fire hazard and/or death.

High altitude and propane (LP) conversions are required in order for the appliance to satisfactorily meet the application.

An authorized distributor or dealer must make all gas conversions.

In Canada, a certified conversion station or other qualified agency, using factory specified and/or approved parts, must perform the conversion.

The installer must take every precaution to insure that the furnace has been converted to the proper gas orifice size when the furnace is installed. Do not attempt to drill out any orifices to obtain the proper orifice size. Drilling out a gas orifice will cause misalignment of the burner flames, causing premature heat exchanger burnout, high levels of carbon monoxide, excessive sooting, a fire hazard, personal injury, property damage and/or death.

## SECTION V: ELECTRICAL POWER

### ELECTRICAL POWER CONNECTIONS

Field wiring to the unit must be grounded. Electric wires that are field installed shall conform to the temperature limitation for 63° F (35° C) rise wire when installed in accordance with instructions. Refer to Table 6 in these instructions for specific furnace electrical data.

The residential supply must have a bonded neutral.

## ⚠ CAUTION

Use copper conductors only.

**Table 6:** Ratings & Physical / Electrical Data

High Fire Input		Low Fire Input		High Fire Output		Low Fire Output		Nominal Airflow		Recommended Fuse or Circuit Breaker Amps	Max. Outlet Air Temp	
MBH	kW	MBH	kW	MBH	kW	MBH	kW	CFM	m3/min		°F	°C
60	17.6	39	11.4	48	14.1	31.2	9.2	1200	34.0	15	190	88
80	23.5	52	15.2	64	18.8	41.6	12.2	1200	34.0	15	190	88
80	23.5	52	15.2	64	18.8	41.6	12.2	1600	45.3	15	190	88
100	29.3	65	19	80	23.4	52	15.2	1600	45.3	15	190	88
100	29.3	65	19	80	23.4	52	15.2	2000	56.6	15	190	88
120	35.1	78	22.8	96	28.1	62.4	18.3	2000	56.6	15	190	88
High Fire Air Temp. Rise		Low Fire Air Temp. Rise		Blower		Blower Size		AFUE	Total Unit Amps	Gas Pipe Connection, NPT	Operating Weight	
°F	°C	°F	°C	HP	Amps	In.	cm				Lbs.	Kg.
30-60	17-33	20-50	11-28	1/2	6.4	11 x 8	27.9x20.3	80.0	9.0	1/2"	94	43
30-60	17-33	20-50	11-28	1/2	6.4	11 x 8	27.9x20.3	80.0	9.0	1/2"	103	47
30-60	17-33	20-50	11-28	1/2	6.4	11 x 10	27.9x25.4	80.0	9.0	1/2"	114	52
30-60	17-33	20-50	11-28	1/2	6.4	11 x 10	27.9x25.4	80.0	8.9	1/2"	118	54
30-60	17-33	20-50	11-28	3/4	8.8	11 x 11	27.9x27.9	80.0	11.3	1/2"	122	55
35-65	19-36	20-50	11-28	3/4	8.8	11 x 11	27.9x27.9	80.0	11.3	1/2"	129	59

Annual Fuel Utilization Efficiency (AFUE) numbers are determined in accordance with DOE Test procedures.

Wire size and over current protection must comply with the National Electrical Code (NFPA-70-latest edition) and all local codes.

The furnace shall be installed so that the electrical components are protected from water.

## SUPPLY VOLTAGE CONNECTIONS

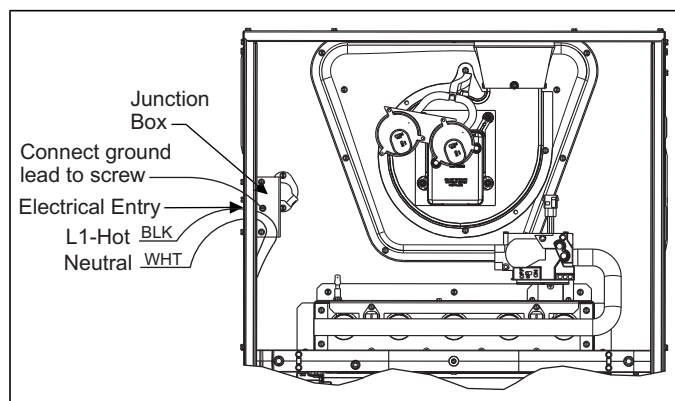

**FIGURE 11:** Electrical Wiring

1. Provide a power supply separate from all other circuits. Install over-current protection and disconnect switch per local/national electrical codes. The switch should be close to the unit for convenience in servicing. With the disconnect or fused switch in the OFF position, check all wiring against the unit wiring label. Refer to the wiring diagram in this instruction.
2. Remove the screws retaining the wiring box cover. Route the power wiring through the opening in the unit into the junction box with a conduit connector or other proper connection. In the junction box there will be 2 wires, a Black Wire, and a White Wire. Connect the power supply as shown on the unit-wiring label on the inside of the blower compartment door or the wiring schematic (see Figure 21). The black furnace lead must be connected to the L1 (hot) wire from the power supply. The white furnace screw must be connected to neutral. Connect the power supply ground to the green screw (equipment ground) An alternate wiring method is to use a field provided 2" (5.1 cm) x 4" (10.2 cm) box and cover on the outside of the furnace. Route the furnace leads into the box using a protective bushing where the wires pass through the furnace panel. After

making the wiring connections replace the wiring box cover and screws. Refer to Figure 11.

3. The furnace's control system requires correct polarity of the power supply and a proper ground connection. Refer to Figure 11.

**IMPORTANT:** The power connection leads and wiring box may be relocated to the opposite side of the furnace. Remove the screws and cut wire tie holding excess wiring. Reposition on the left side of the furnace and fasten using holes provided.

## LOW VOLTAGE CONTROL WIRING CONNECTIONS

Install the field-supplied thermostat by following the instructions that come with the thermostat. With the thermostat set in the OFF position and the main electrical source disconnected, connect the thermostat wiring from the wiring connections on the thermostat to the terminal board on the ignition module, as shown in Figures 12 or 13. Electronic thermostats require the common wire to be connected. Do not use power stealing thermostats. Apply strain relief to thermostat wires passing through cabinet. If air conditioning equipment is installed, use thermostat wiring to connect the Y and C terminals on the furnace control board to the proper wires on the outdoor unit.

**IMPORTANT:** Set the heat anticipator in the room thermostat to 0.4 amps. Setting it lower will cause short cycles. Setting it higher will cause the room temperature to exceed the set points.

**IMPORTANT:** Some electronic thermostats do not have adjustable heat anticipators. They should be set to six cycles per hour. Follow the thermostat manufacturer's instructions.

The 24-volt, 40 VA transformer is sized for the furnace components only, and should not be connected to power auxiliary devices such as humidifiers, air cleaners, etc. The transformer may provide power for an air conditioning unit contactor.

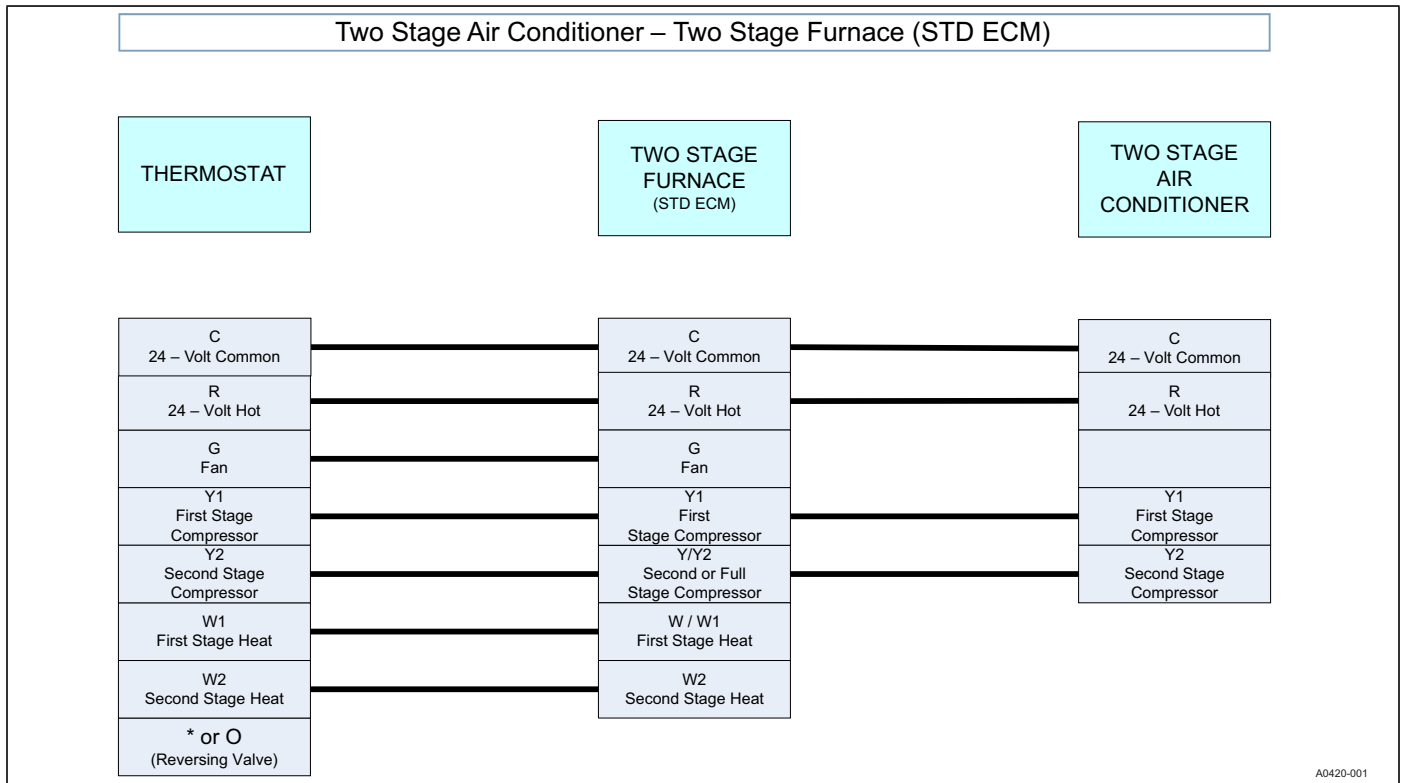

**FIGURE 12:** Thermostat Chart - Two Stage AC with Two Stage Standard ECM Furnaces

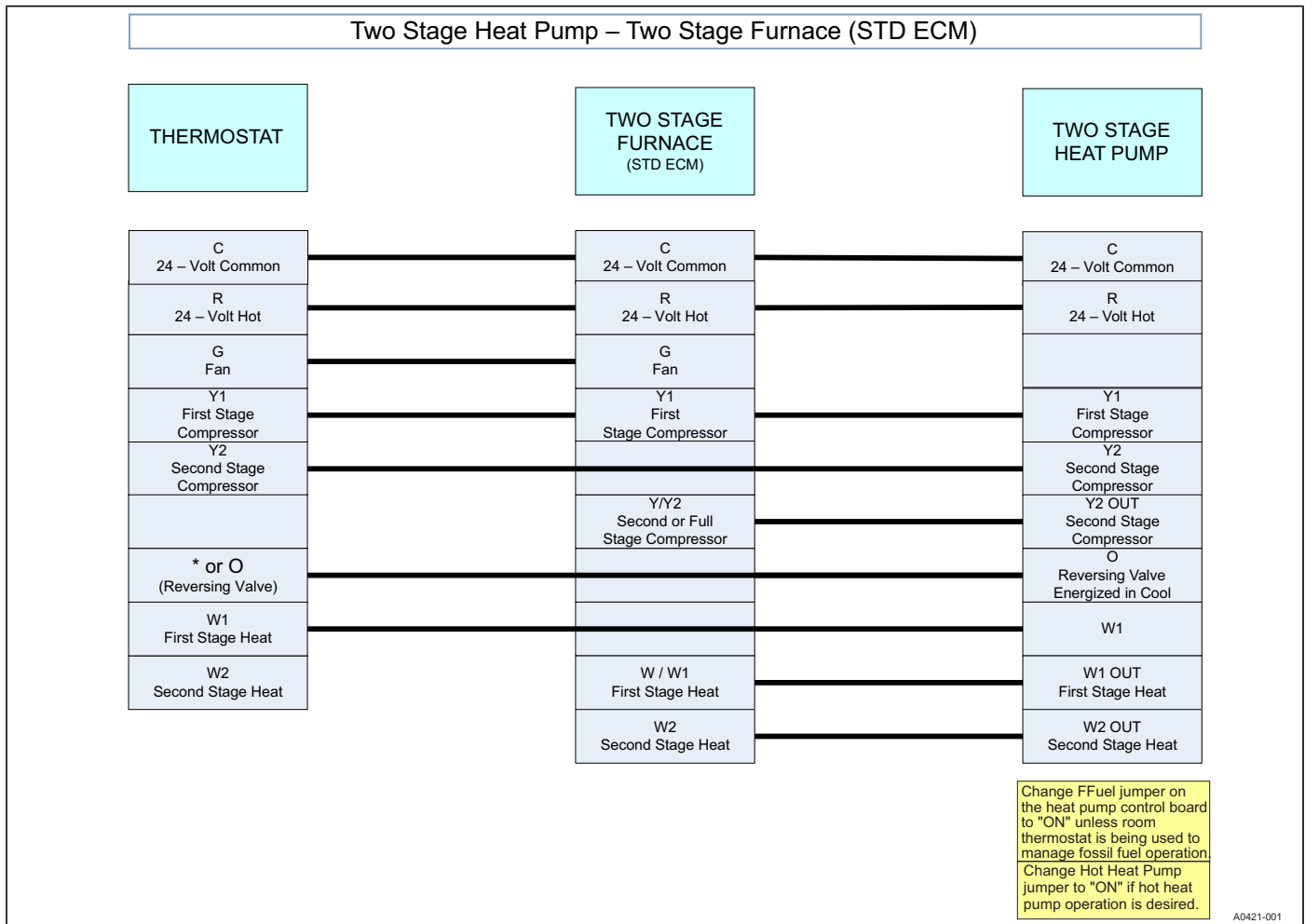

**FIGURE 13:** Thermostat Chart - Two Stage HP with Two Stage Standard ECM Furnace

## ACCESSORY CONNECTIONS

The furnace control will allow power-switching control of various accessories.

### ELECTRONIC AIR CLEANER CONNECTION

Two 1/4" (0.64 cm) spade terminals (EAC-H and NEUTRAL) for electronic air cleaner connections are located on the control board. The terminals provide 115 VAC (1.0 amp maximum) during circulating blower operation.

### HUMIDIFIER CONNECTION

Two 1/4" (0.64 cm) spade terminals (HUM and NEUTRAL) for humidifier connections are located on the control board. The terminals provide 115 VAC (1.0 amp maximum) during heating system operation.

A mounting hole is provided on the control panel next to the furnace control board for mounting a humidifier transformer if required.

### SINGLE STAGE THERMOSTAT (Optional)

If a single stage thermostat is used, the high/low input staging will be controlled by the furnace control board. Using the dipswitch settings the control provides multiple options for furnace staging. If the staging dipswitches are set to 10 or 20 position, the furnace will switch from low fire to high fire after 10 or 20 minutes and will stay in high fire until the thermostat is satisfied.

If the staging dipswitches are set to AUTO position, the furnace will automatically stage from low fire to high fire, using recent heating duty cycle information in an adaptive algorithm to determine the optimal time to energize 2nd stage operation. This provides two stage heating capability with single stage thermostat.

If the staging dipswitches are set to OFF position and a single stage thermostat is used, the furnace will only operate at low fire.

## SECTION VI: TWINNING

These furnaces are not to be twinned. If more than one furnace is needed in an application, each furnace must have its own complete duct system and its own wall thermostat.

## SECTION VII: VENTING

### VENT CONNECTIONS

All models are provided with a flue transition that is sized for 4" diameter vent connections. If a larger size vent connector is required, that connection must be installed external to the furnace. Figure 14 shows the furnace as it is shipped from the factory. To convert to a horizontal or downflow position, remove the four screws that secure the inducer assembly and rotate 90° being careful not to damage the gasket. Reinstall screws. Remove cap from appropriate vent outlet location on the cabinet, cut insulation in cabinet to same size as the hole provided and reinstall cap in the hole in the top panel.

**IMPORTANT:** In downflow applications, do not block the combustion air inlet. The furnace must be installed on a coil cabinet or subbase to allow combustion air to enter the burner compartment.

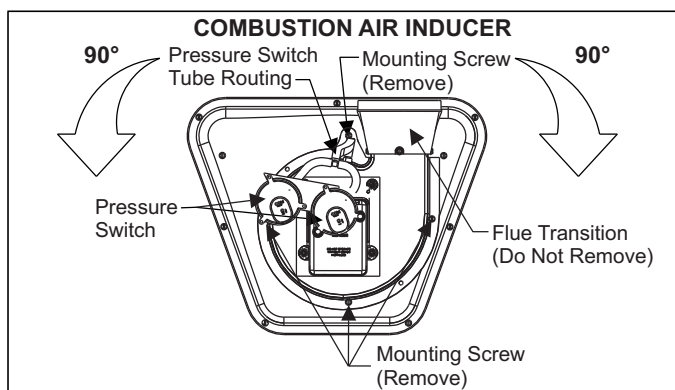

FIGURE 14: Combustion Air Inducer

### CATEGORY 1 - 450 F. MAX. VENT TEMP.

The venting system must be installed in accordance with Section 5.3, Air for Combustion and Ventilation, of the National Fuel Gas Code Z223.1/NFPA 54 (latest edition), or Sections 7.2, 7.3 or 7.4 of CSA B149.1, National Gas and Propane Codes (latest edition) or applicable provisions of the local building code and these instructions.

The furnace shall be connected to any type of B, BW or L vent connector, and shall be connected to a factory-built or masonry chimney. **The furnace shall not be connected to a chimney flue serving a separate appliance designed to burn solid fuel.**

It is recommended that the appliance is installed in a location where the space temperature is 32° F (0° C) or higher. If the appliance is installed in a location where the ambient temperature is below 32° F (0° C), the combustion byproducts could condense causing damage to the appliance heat exchanger.

This appliance may be common vented with another gas appliance for residential installations as allowed by the codes and standards listed in these instructions.

Non-HUD approved Modular Homes must be vented with an approved roof jack and may not be common vented with other appliances.

### VENTING

Category I venting consists of vertically venting one or more appliances in B-vent or masonry chimney (as allowed), using single wall metal pipe or B-vent connectors. Type B-vent system extends in a general vertical direction and does not contain offsets exceeding 45°. A vent system having not more than one 60° offset is permitted.

A single, properly sized pipe from the furnace vent connector to the outdoors must be provided.

### VENTING INTO AN EXISTING CHIMNEY

For Category I installations, the furnace shall be connected to a factory built chimney or vent complying with a recognized standard, or a masonry or concrete chimney lined with a material acceptable to the authority having jurisdiction. Venting into an unlined masonry chimney or concrete chimney is prohibited.

Where use of an existing chimney is unavoidable, the following rules must be followed:

1. The masonry chimney must be built and installed in accordance with nationally recognized building codes or standards and must be lined with approved fire clay tile flue liners or other approved liner material that will resist corrosion, softening, or cracking from flue gases. **THIS FURNACE IS NOT TO BE VENTED INTO AN UNLINED MASONRY CHIMNEY.**
2. This furnace must be vented into a fire clay tile lined masonry chimney only if a source of dilution air is provided, such as by common venting with a draft hood equipped water heater. If no source of dilution air is available, Type B vent must be used, or masonry chimney vent kit S1-1CK0604 must be used. Refer to the instructions with the kit to properly apply these masonry chimney kits.
3. The chimney must extend at least 3 ft (0.91 m) above the highest point where it passes through a roof of a building and at least two feet higher than any portion of the building with a horizontal distance of ten feet.
4. The chimney must extend at least 5 ft (1.5 m) above the highest equipment draft hood or flue collar.

## FAN-ASSISTED COMBUSTION SYSTEM

This appliance is equipped with an integral mechanical means to either draw products of combustion through the heat exchanger.

### Ambient Combustion Air Supply

This type installation will draw the air required for combustion from within the space surrounding the appliance and from areas or rooms adjacent to the space surrounding the appliance. This may be from within the space in a non-confined location or it may be brought into the furnace area from outdoors through permanent openings or ducts. Combustion air is brought into the furnace through the unit top panel opening.

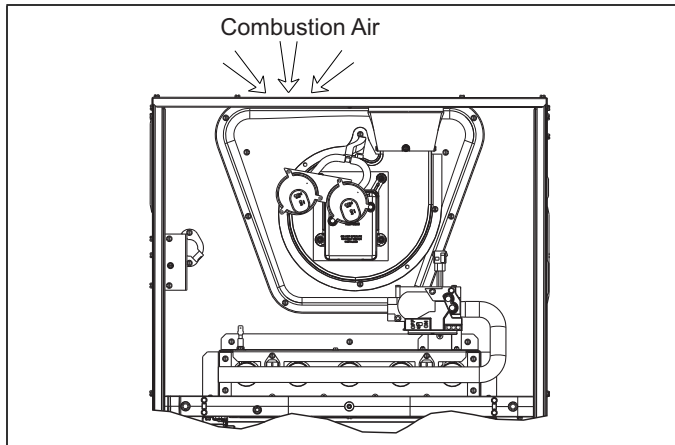

**FIGURE 15:** Combustion Airflow Path Through The Furnace Casing to the Burner Compartment

### ⚠ WARNING

This type of installation requires that the supply air to the appliance(s) be of a sufficient amount to support all of the appliance(s) in the area. Operation of a mechanical exhaust, such as an exhaust fan, kitchen ventilation system, clothes dryer or fireplace may create conditions requiring special attention to avoid unsatisfactory operation of gas appliances. A venting problem or a lack of supply air will result in a hazardous condition, which can cause the appliance to soot and generate dangerous levels of CARBON MONOXIDE, which can lead to serious injury, property damage and / or death.

An **unconfined space** is not less than 50 cu.ft (1.42 m<sup>3</sup>) per 1,000 Btu/hr (0.2928 kW) input rating for all of the appliances installed in that area.

Rooms communicating directly with the space containing the appliances are considered part of the unconfined space, if doors are furnished with openings or louvers.

A **confined space** is an area with less than 50 cu.ft (1.42 m<sup>3</sup>) per 1,000 Btu/hr (0.2928 kW) input rating for all of the appliances installed in that area. The following must be considered to obtain proper air for combustion and ventilation in confined spaces.

### Combustion Air Source From Outdoors

The blocking effects of louvers, grilles and screens must be given consideration in calculating free area. If the free area of a specific louver or grille is not known, refer to Table 7, to estimate free area.

**Table 7:** Estimated Free Area

Wood or Metal Louvers or Grilles	Wood 20-25%* Metal 60-70% *
Screens+	1/4" (0.635 cm) mesh or larger 100%

\* Do not use less than 1/4"(0.635 cm) mesh

+ Free area of louvers and grille varies widely; the installer should follow louver or grille manufacturer's instructions.

### Dampers, Louvers and Grilles (Canada Only)

1. The free area of a supply air opening shall be calculated by subtracting the blockage area of all fixed louvers grilles or screens from the gross area of the opening.
2. Apertures in a fixed louver, a grille, or screen shall have no dimension smaller than 0.25" (0.64 cm).
3. A manually operated damper or manually adjustable louvers are not permitted for use.
4. A automatically operated damper or automatically adjustable louvers shall be interlocked so that the main burner cannot operate unless either the damper or the louver is in the fully open position.

### ⚠ WARNING

When a Category I furnace is removed or replaced, the original venting system may no longer be correctly sized to properly vent the attached appliances.

An improperly sized vent system can cause CARBON MONOXIDE to spill into the living space causing personal injury, and or death.

**Table 8:** Unconfined Space Minimum Area

BTUH Input Rating	Minimum Free Area Required for Each Opening
60,000	60 in <sup>2</sup> (387 cm <sup>2</sup> )
80,000	80 in <sup>2</sup> (516 cm <sup>2</sup> )
100,000	100 in <sup>2</sup> (645 cm <sup>2</sup> )
120,000	120 in <sup>2</sup> (742 cm <sup>2</sup> )

**Table 9:** Free Area

BTUH Input Rating	Minimum Free Area Required for Each Opening		
	Horizontal Duct (2,000 BTUH)	Vertical Duct or Opening to Outside (4,000 BTUH)	Round Duct (4,000 BTUH)
60,000	30 in <sup>2</sup> (193 cm <sup>2</sup> )	15 in <sup>2</sup> (97 cm <sup>2</sup> )	5" (13 cm)
80,000	40 in <sup>2</sup> (258 cm <sup>2</sup> )	20 in <sup>2</sup> (129 cm <sup>2</sup> )	5" (13 cm)
100,000	50 in <sup>2</sup> (322 cm <sup>2</sup> )	25 in <sup>2</sup> (161 cm <sup>2</sup> )	6" (15 cm)
120,000	60 in <sup>2</sup> (387 cm <sup>2</sup> )	30 in <sup>2</sup> (193 cm <sup>2</sup> )	7" (18 cm)

EXAMPLE: Determining Free Area.

Appliance	1 Appliance	2 Total Input
100,000	+ 30,000 = (130,000 ÷ 4,000) = 32.5 Sq. In. Vertical	
Appliance	1 Appliance	2 Total Input
100,000	+ 30,000 = (130,000 ÷ 2,000) = 65 Sq. In. Horizontal	

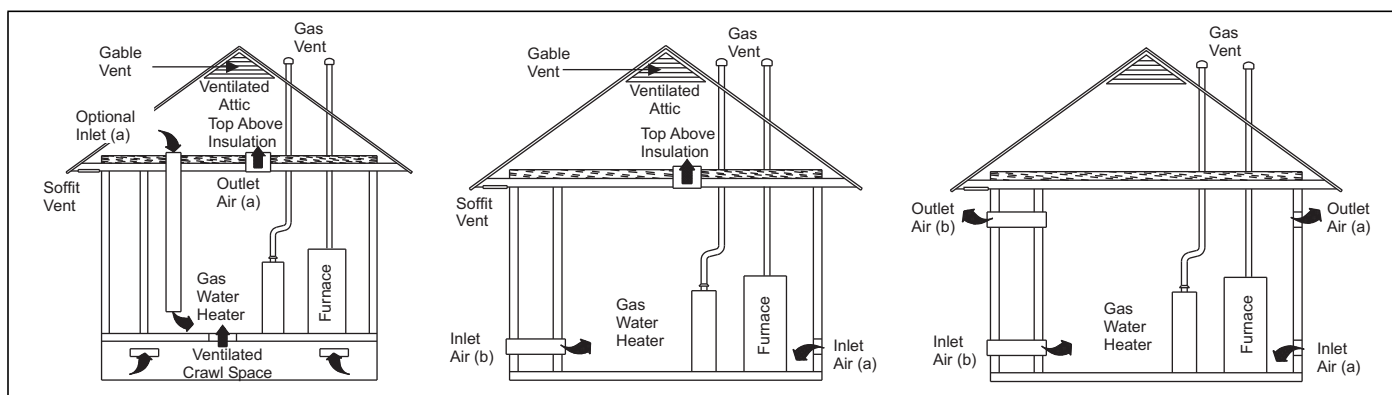

**FIGURE 16:** Ambient Combustion Air

### Air Supply Openings and Ducts

1. An opening may be used in lieu of a duct to provide the outside air supply to an appliance unless otherwise permitted by the authority having jurisdiction. The opening shall be located within 12" (30.5 cm) horizontally from the burner level of the appliance. Refer to "COMBUSTION AIR SOURCE FROM OUTDOORS AND SUPPLY AIR SAFETY CHECK" in these instructions for additional information and safety check procedure.
2. The duct shall be either metal, or a material meeting the class 1 requirements of CAN4-S110 Standard for Air Ducts.
3. The duct shall be least the same cross-sectional area as the free area of the air supply inlet opening to which it connects.
4. The duct shall terminate within 12 in (30.5 cm) above, and within 24 in (61 cm) horizontally from, the burner level of the appliance having the largest input.
5. A square or rectangular shaped duct shall only be used when the required free area of the supply opening is 9 in<sup>2</sup> (58.06 cm<sup>2</sup>) or larger. When a square or rectangular duct is used, its small dimension shall not be less than 3 in (7.6 cm).
6. An air inlet supply from outdoors shall be equipped with a means to prevent the direct entry of rain and wind. Such means shall not reduce the required free area of the air supply opening.
7. An air supply inlet opening from the outdoors shall be located not less than 12" (30.5 cm) above the outside grade level.

### Combustion Air Source from Outdoors

1. Two permanent openings, one within 12 in (30.5 mm) of the top and one within 12 in (30.5 mm) of bottom of the confined space, Two permanent openings, shall communicate directly or by means of ducts with the outdoors, crawl spaces or attic spaces.
2. One permanent openings, commencing within 12 in (30.5 mm) of the top of the enclosure shall be permitted where the equipment has clearances of at least 1 in (2.54 cm) from the sides and back and 6 in (15.24 cm) from the front of the appliance. The opening shall communicate directly with the outdoors and shall have a minimum free area of:
  - a. 1 in.<sup>2</sup> / 3,000 BTU/hr (700mm<sup>2</sup>/kW) of the total input rating of all equipment located in the enclosure.
  - b. Not less than the sum of all vent connectors in the confined space.

3. The duct shall be least the same cross-sectional area as the free area of the air supply inlet opening to which it connects.
4. The blocking effects of louvers, grilles and screens must be given consideration in calculating free area. If the free area of a specific louver or grille is not known. Refer to Table 7 to estimate free area.

### Ventilated Combustion Air

The ventilated attic space or a crawl space from which the combustion air is taken must comply with the requirements specified in "AIR SOURCE FROM OUTDOORS" in this instruction or in Section 5.3, Air for Combustion and Ventilation of the National Fuel Gas Code, ANSI Z223.1 (latest edition). This type installation requires two properly sized pipes. One brings combustion air from a properly ventilated attic space or crawl space and a second pipe that extends from the furnace vent connection (top right of unit) to the exterior of the building.

### Vent and Supply (Outside) Air Safety Check Procedure

For Category I furnaces, vent installations shall be in accordance with Parts 7 and 11 of the National Fuel Gas Code, ANSI Z223.1/NFPA 54, and or Section 7 and Appendix B of the CSA B149.1, Natural Gas and Propane Installation Codes, the local building codes, furnace and vent manufactures instructions.

Multi-story or common venting systems are permitted and must be installed in accordance with the National Fuel Gas Code, ANSI Z223.1/NFPA 54 and / or the CSA B149.1, Natural Gas and Propane Installation Codes, local codes, and the manufactures instructions.

Vent connectors serving Category I furnaces shall not be connected into any portion of mechanical draft systems operating under positive pressure.

Horizontal portions of the venting system shall be supported to prevent sagging using hangers or perforated straps and must slope upwards not less than 1/4" per foot (0.635 cm/m) from the furnace to the vent terminal.

It is recommended that you follow the venting safety procedure below. This procedure is designed to detect an inadequate ventilation system that can cause the appliances in the area to operate improperly causing unsafe levels of Carbon Monoxide or an unsafe condition to occur.

## ⚠ WARNING

### CARBON MONOXIDE POISONING HAZARD

Failure to follow the steps outlined below for each appliance connected to the venting system being placed into operation could result in carbon-monoxide poisoning or death.

The following steps shall be followed for each appliance connected to the venting system being placed into operation, while all other appliances connected to the venting system are not in operation:

1. Inspect the venting system for proper size and horizontal pitch. Determine that there is no blockage, restriction, leakage, corrosion or other deficiencies, which could cause an unsafe condition
2. Close all building doors and windows.
3. Turn on clothes dryers and TURN ON any exhaust fans, such as range hoods and bathroom exhausts, so they shall operate at maximum speed. Open the fireplace dampers. Do not operate a summer exhaust fan.
4. Follow the lighting instructions. Place the appliance being inspected in operation. Adjust thermostat so the appliance shall operate continuously.
5. Test each appliance (such as a water heater) equipped with a draft hood for spillage (down-draft or no draft) at the draft hood relief opening after 5 minutes of main burner operation. Appliances that do not have draft hoods need to be checked at the vent pipe as close to the appliance as possible. Use a combustion analyzer to check the CO<sub>2</sub> and CO levels of each appliance. Use a draft gauge to check for a downdraft or inadequate draft condition.
6. After it has been determined that each appliance properly vents when tested as outlined above, return doors, windows, exhaust fans, fireplace dampers and any other gas burning appliance to their normal condition.
7. If improper venting is observed during any of the above tests, a problem exists with either the venting system or the appliance does not have enough combustion air (Supply Air from outside) to complete combustion. This condition must be corrected before the appliance can function safely.

**NOTE:** An unsafe condition exists when the CO reading exceeds 40 ppm and the draft reading is not in excess of - 0.1 in. W.C. (-25 kPa) with all of the appliance(s) operating at the same time.

8. Any corrections to the venting system and / or to the supply (outside) air system must be in accordance with the National Fuel Gas Code Z223.1 or CAN/CGA B149.1 Natural Gas and Propane Installation Code (latest editions). If the vent system must be resized, follow the appropriate tables in Appendix G of the above codes or for this appliance.

## SECTION VIII: START-UP AND ADJUSTMENTS

The following start-up checks **MUST** be performed by the furnace installer on every new furnace installation.

1. Gas piping leak check.
2. Furnace input rate check.
3. Air temperature rise check.

Instructions on how to perform each of these required installation checks are listed in the sections below.

**IMPORTANT:** All electrical connections made in the field and in the factory should be checked for proper tightness.

When the gas supply is initially connected to the furnace, the gas piping may be full of air. In order to purge this air, it is recommended that the ground union be loosened until the odor of gas is detected. When gas is detected, immediately retighten the union and check for leaks. Allow five minutes for any gas to dissipate before continuing with the start-up procedure. Be sure proper ventilation is available to dilute and carry away any vented gas.

### NO<sub>x</sub> SCREEN REMOVAL (Lo-NO<sub>x</sub> Models Only)

If the furnace is equipped with NO<sub>x</sub> screens and when it is to be used with LP (propane) gas, the screens must be removed prior to start-up.

1. Make sure that the electrical power to the unit is turned off and that the gas supply is turned off at the shut-off valve.
2. Remove the blower compartment and burner compartment access doors.
3. Disconnect the gas supply piping at the union to permit removal of the entire burner and gas control assembly from the vestibule panel. Use the wrench boss on the gas valve when removing or installing the piping.
4. Unplug the igniter from the wire harness. Disconnect the flame sensor wires located on top of the air shield. Unplug the gas valve from the wiring harness.
5. Remove the screws holding the burner assembly to the vestibule panel.
6. Remove the burner assembly. It should be possible to swing the burner assembly out of the way without disconnecting the remaining wires.

7. With the burner assembly out of the way, simply slide the NO<sub>x</sub> screens out of the heat exchanger tubes and discard the screens.
8. Replace all components in reverse order. Reconnect all wiring.

### GAS PIPING LEAK CHECK

## ⚠ WARNING

### FIRE OR EXPLOSION HAZARD

Failure to follow the safety warnings exactly could result in serious injury, death or property damage.

Never test for gas leaks with an open flame. Use a commercially available soap solution made specifically for the detection of leaks to check all connections. A fire or explosion may result causing property damage, personal injury or loss of life.

**IMPORTANT:** Burner ignition may not be satisfactory on first startup due to residual air in the gas line or until gas manifold pressure is adjusted. The ignition control will make three attempts to light before locking out.

It is recommended that when the gas supply is first connected to the furnace, the ground union be loosened until the odor of gas is detected. When gas is detected, immediately tighten the union and check for gas leaks. Allow five minutes for any gas to dissipate before continuing with the start-up procedure. Be sure that proper ventilation is available to dilute and carry away any vented gas.

With furnace in operation, check all of the pipe joints, gas valve connections and manual valve connections for leakage using an approved gas detector, a non-corrosive leak detection fluid or other leak detection methods. Take appropriate action to stop any leak. If a leak persists, replace the faulty component.

The furnace and its equipment shut-off valve must be disconnected from the gas supply during any pressure testing of that system at test pressures in excess of 1/2 PSI (3.45 kPa).

The furnace must be isolated from the gas supply piping system by closing the equipment shut-off valve during any pressure testing of the gas supply system.



## IGNITION SYSTEM SEQUENCE

1. Turn the gas supply ON at external valve and main gas valve.
2. Set the thermostat above room temperature to call for heat.
3. System start-up will occur as follows:
  - a. The induced draft blower motor will start and come up to speed. Shortly after inducer start-up, the hot surface igniter will glow for about 17 seconds.
  - b. After this warm up, the ignition module will energize (open) the main gas valve.
  - c. The furnace will light at the high-fire input rate. If the thermostat is calling for low fire, the firing rate will drop to low fire after flame is established.
  - d. After flame is established, the supply air blower will start in about 30 seconds.

**IMPORTANT:** Burner ignition may not be satisfactory on first startup due to residual air in the gas line or until gas manifold pressure is adjusted. The ignition control will make 3 attempts to light before locking out.

With furnace in operation, check all of the pipe joints, gas valve connections and manual valve connections for leakage using an approved gas detector, a non-corrosive leak detection fluid, or other leak detection methods. Take appropriate steps to stop any leak. If a leak persists, replace the component.

## CALCULATING THE FURNACE INPUT (NATURAL GAS)

### NOTICE

Burner orifices are sized to provide proper input rate using natural gas with a heating value of 1030 BTU/Ft<sup>3</sup> (38.4 MJ/m<sup>3</sup>). If the heating value of your gas is significantly different, it may be necessary to replace the orifices.

### NOTICE

**DO NOT** set manifold pressure less than 3.2 in wc or more than 3.8 in wc for natural gas at sea level. If manifold pressure is outside this range, change main burner orifices.

### CAUTION

**DO NOT** bottom out gas valve regulator adjusting screw. This can result in unregulated manifold pressure and result in excess overfire and heat exchanger failures.

### NOTICE

If orifice hole appears damaged or it is suspected to have been redrilled, check orifice hole with a numbered drill bit of correct size. Never redrill an orifice. A burr-free and squarely aligned orifice hole is essential for proper flame characteristics.

Verify natural gas input rate by clocking meter.

1. Turn off all other gas appliances and pilots.
2. Run furnace for a minimum of 3 minutes in heating operation.
3. Measure time (in sec) for gas meter to complete 1 revolution and note reading. The 2 cubic feet dial provides a more accurate measurement of gas flow.
4. Refer to Table 10 for cubic feet of gas per hour.
5. Multiply cubic feet per hour by heating value (BTU/cu ft) to obtain input.

If clocked rate does not match the input rate from the unit nameplate, follow steps in next section to adjust the manifold pressure. Repeat steps 2 - 5 until correct input is achieved.

### CAUTION

Be sure to relight any gas appliances that were turned off at the start of this input check.

**Table 10:** Gas Rate (CU FT/HR)

Seconds For 1 Revolution	Size of Test Dial		
	1 Cu Ft	2 Cu Ft	5 Cu Ft
10	360	720	1800
11	327	655	1636
12	300	600	1500
13	277	555	1385
14	257	514	1286
15	240	480	1200
16	225	450	1125
17	212	424	1059
18	200	400	1000
19	189	379	947
20	180	360	900
21	171	343	857
22	164	327	818
23	157	313	783
24	150	300	750
25	144	288	720
26	138	277	692
27	133	267	667
28	129	257	643
29	124	248	621
30	120	240	600
31	116	232	581
32	113	225	563
33	109	218	545
34	106	212	529
35	103	206	514
36	100	200	500
37	97	195	486
38	95	189	474
39	92	185	462
40	90	180	450
41	88	176	439
42	86	172	429
43	84	167	419
44	82	164	409
45	80	160	400
46	78	157	391
47	76	153	383
48	75	150	375
49	73	147	367

Seconds For 1 Revolution	Size of Test Dial		
	1 Cu Ft	2 Cu Ft	5 Cu Ft
50	72	144	360
51	71	141	355
52	69	138	346
53	68	136	340
54	67	133	333
55	65	131	327
56	64	129	321
57	63	126	316
58	62	124	310
59	61	122	305
60	60	120	300
62	58	116	290
64	56	112	281
66	54	109	273
68	53	106	265
70	51	103	257
72	50	100	250
74	48	97	243
76	47	95	237
78	46	92	231
80	45	90	225
82	44	88	220
84	43	86	214
86	42	84	209
88	41	82	205
90	40	80	200
92	39	78	196
94	38	76	192
96	38	75	188
98	37	74	184
100	36	72	180
102	35	71	178
104	35	69	173
106	34	68	170
108	33	67	167
110	33	65	164
112	32	64	161
116	31	62	155
120	30	60	150

#### ADJUSTMENT OF MANIFOLD GAS PRESSURE & INPUT RATE

Inlet and manifold gas pressure may be measured by connecting the "U" tube manometer to the gas valve with a piece of tubing. Follow the appropriate section in the instructions below. Refer to Figure 17 for a drawing of the locations of the pressure ports on the gas valve.

#### Turn gas off at the ball valve or gas cock on gas supply line before the gas valve. Find the pressure ports on the gas valve marked Out P and In P.

1. The manifold pressure must be taken at the port marked OUT P.
2. The gas line pressure must be taken at the port marked IN P.
3. Using a 3/32" (2.4 mm) hex head wrench, loosen the set screw by turning it 1 turn counter clockwise. DO NOT REMOVE THE SET SCREW FROM THE PRESSURE PORT.

#### Read the inlet gas pressure

Connect the positive side of the manometer to the IN P Tap on the gas valve. Do not connect any tubing to the negative side of the manometer, as it will reference atmospheric pressure. Refer to Figure 18 for connection details.

1. Turn gas and electrical supplies on and follow the operating instructions to place the unit back in operation.

**Table 11:** Inlet Gas Pressure Range

INLET GAS PRESSURE RANGE		
	Natural Gas	Propane (LP)
Minimum*	4.5" W.C. (1.12 kPa)	8.0" W.C. (1.99 kPa)
Maximum	10.5" W.C. (2.61 kPa)	13.0" (3.24 kPa) W.C.

**IMPORTANT:** The inlet gas pressure operating range table specifies what the minimum and maximum gas line pressures must be for the furnace to operate safely. The gas line pressure **MUST BE** a minimum of:

- 7" w.c. (1.74 kPa) for Natural Gas
- 11" w.c. (2.74 kPa) for Propane (LP) Gas

in order to obtain the BTU input specified on the rating plate and/or the nominal manifold pressure specified in these instructions and on the rating plate.

- Once the correct gas inlet pressure has been established, see Table 11, turn the gas valve to OFF and turn the electrical supply switch to OFF; then remove the flexible tubing from the gas valve pressure tap and tighten the pressure tap plug using the 3/32" (2.4 mm) hex head wrench.
- Turn the electrical and gas supplies back on, and with the burners in operation, check for gas leakage around the gas valve pressure port for leakage using an approved non-corrosive gas leak detection fluid, or other non-flammable leak detection methods.

### Read the manifold gas pressure

Connect the positive side of the manometer to the adapter previously installed in the OUT P Tap on the gas valve. Do not connect any tubing to the negative side of the manometer, as it will reference atmospheric pressure. Refer to Figure 18 for connection details.

**IMPORTANT:** The cap for the pressure regulator must be removed entirely to gain access to the adjustment screw. Loosening or tightening the cap does not adjust the flow of gas.

- Refer to Figure 17 for location of pressure regulator adjustment cap and adjustment screws on main gas valve.
- Turn gas and electrical supplies on and follow the operating instructions to place the unit back in operation.

## NOTICE

This furnace uses a two stage gas valve. The high-fire and low-fire manifold pressures can be adjusted independently.

- Place jumper wire from W1 to W2 to R on the furnace control board for the furnace to operate HIGH fire. Once correct manifold pressure is set (HI), remove jumper from W2 for the furnace to operate on low fire. Set the manifold pressure (LO) to correct manifold pressure.

**Table 12:** Nominal Manifold Pressure

NOMINAL MANIFOLD PRESSURE		
	High Fire	Low Fire
Natural Gas	3.5" w.c. (0.87 kPa)	1.6" w.c. (0.40 kPa)
Propane (LP) Gas	9.8" w.c. (2.44 kPa)	4.0" w.c. (0.99 kPa)

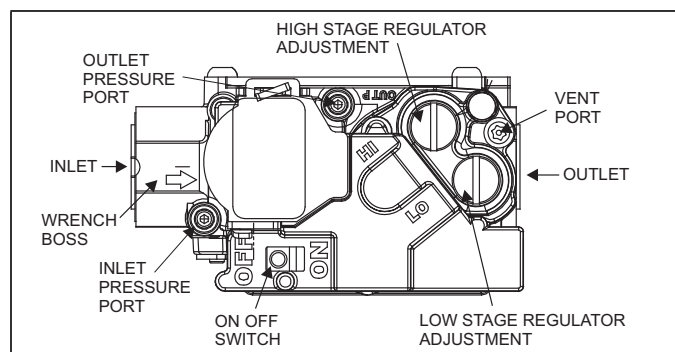

**FIGURE 17:** Gas Valve

**IMPORTANT:** If gas valve regulator is turned in (clockwise), manifold pressure is increased. If screw is turned out (counterclockwise), manifold pressure will decrease.

- After the manifold pressure has been adjusted, re-calculate the furnace input to make sure you have not exceeded the specified input on the rating plate. Refer to "CALCULATING THE FURNACE INPUT (NATURAL GAS)".
- Once the correct BTU (kW) input has been established, turn the gas valve to OFF and turn the electrical supply switch to OFF; then remove the flexible tubing from the gas valve pressure tap and tighten the pressure tap plug using the 3/32" (2.4 mm) hex head wrench.
- Turn the electrical and gas supplies back on, and with the burners in operation, check for gas leakage around the gas valve pressure port for leakage using an approved non-corrosive gas leak detection fluid, or other non-flammable leak detection methods.

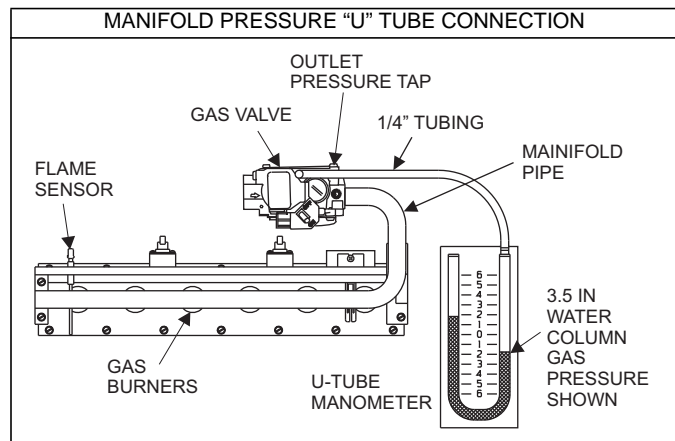

**FIGURE 18:** Reading Gas Pressure

## AIRFLOW SETTINGS

### Cooling Airflow Settings

This unit is equipped with a five-speed blower motor.

The desired cooling airflow may be selected by connecting the desired motor speed tap wire to the HI COOL terminal on the control board. The speed should be selected so as to deliver approximately 350-400 CFM per ton of A/C cooling capacity. Use of airflow outside of this range may result in diminished air conditioning performance and may result in lower overall energy efficiency and higher electric utility bills.

**Table 13: Default Blower Speeds**

Model Number	Default Blower Speeds				
	Hi Heat	LO Heat	HI Cool	LO Cool	Continuous Fan
060A12	Medium High (2)	Medium Low (4)	High (1)	Medium (3)	LO Heat
080B12	Medium High (2)	Medium (3)	High (1)	Medium Low (4)	LO Heat
080C16	Medium High (2)	Medium Low (4)	High (1)	Medium (3)	LO Heat
100C16	Medium High (2)	Medium (3)	High (1)	Medium Low (4)	LO Heat
100C20	Medium High (2)	Medium Low (4)	High (1)	Medium (3)	LO Heat
120C20	Medium High (2)	Medium (3)	High (1)	Medium Low (4)	LO Heat

**Continuous Fan Airflow Settings**

The default blower speed for continuous fan operation is LO HT (Low Heat) speed.

This furnace may be operated in continuous fan mode by setting the wall thermostat FAN switch to ON. To select the desired continuous fan airflow, set the CONT SPEED dip switches on the control board to the desired position. There are four options:

1. With the FAN SPEED dip switches in the “HI CL” position the blower will run during continuous fan operation at the motor speed connected to the “HI COOL” terminal on the control board.
2. With the FAN SPEED dip switches in the “LO CL” position the blower will run during continuous fan operation at the motor speed connected to the “LO COOL” terminal on the control board.
3. With the FAN SPEED dip switches in the “HI HT” position the blower will run during continuous fan operation at the motor speed connected to the “HI HEAT” terminal on the control board.
4. With the FAN SPEED dip switches in the “LO HT” position the blower will run during continuous fan operation at the motor speed connected to the “LO HEAT” terminal on the control board.

The default position is with the dip switches in the “LO HT” position and the LOW speed motor wire on the LO HEAT terminal. In certain circumstances, it may be necessary to move the continuous fan speed to a different speed tap. However, doing so is not recommended since it will result in higher than normal electrical energy usage and higher than normal electric utility bills.

**Gas Heating Airflow Settings**

The default heating blower speed is shown in Table 18.

This unit is equipped with a five-speed blower motor. The heating blower speed is set at the factory to the default blower speed, which is the blower speed that will deliver the correct airflow for proper heating operation in most applications.

In certain circumstances, it may be necessary to move the heating blower speed to a different motor speed tap. Not all five motor speeds are appropriate for gas heating operation. The use of heating airflow on a speed other than the default speed will result in diminished heating performance and may cause the furnace temperature limit controls to shut down the furnace.

**Measurement of Temperature Rise**

**⚠ DANGER**

The temperature rise, or temperature difference between the return air and the supply (heated) air from the furnace, must be within the range shown on the furnace rating plate and within the application limitations shown in SECTION V.

The supply air temperature cannot exceed the **“Maximum Supply Air Temperature”** specified in these instructions and on the furnace rating plate. Under NO circumstances can the furnace be allowed to operate above the Maximum Supply Air Temperature. Operating the furnace above the Maximum Supply Air Temperature will cause premature heat exchanger failure, high levels of Carbon Monoxide, a fire hazard, personal injury, property damage, and/or death.

After about 5 minutes of operation, determine the furnace temperature rise. Measure the temperature of both the return air and the heated air in the ducts, about six feet (1.83 m) from the furnace where they will not be affected by radiant heat. Increase the blower speed to decrease the temperature rise; decrease the blower speed to increase the rise.

The blower speed taps are located on the furnace control board in the blower compartment. Refer to Figure 36, and the unit-wiring label to change the blower speed. To use the same speed tap for heating and cooling, the heat terminal and cool terminal must be connected using a jumper wire and connected to the desired motor lead. Place the unused motor leads on the PARK terminal.

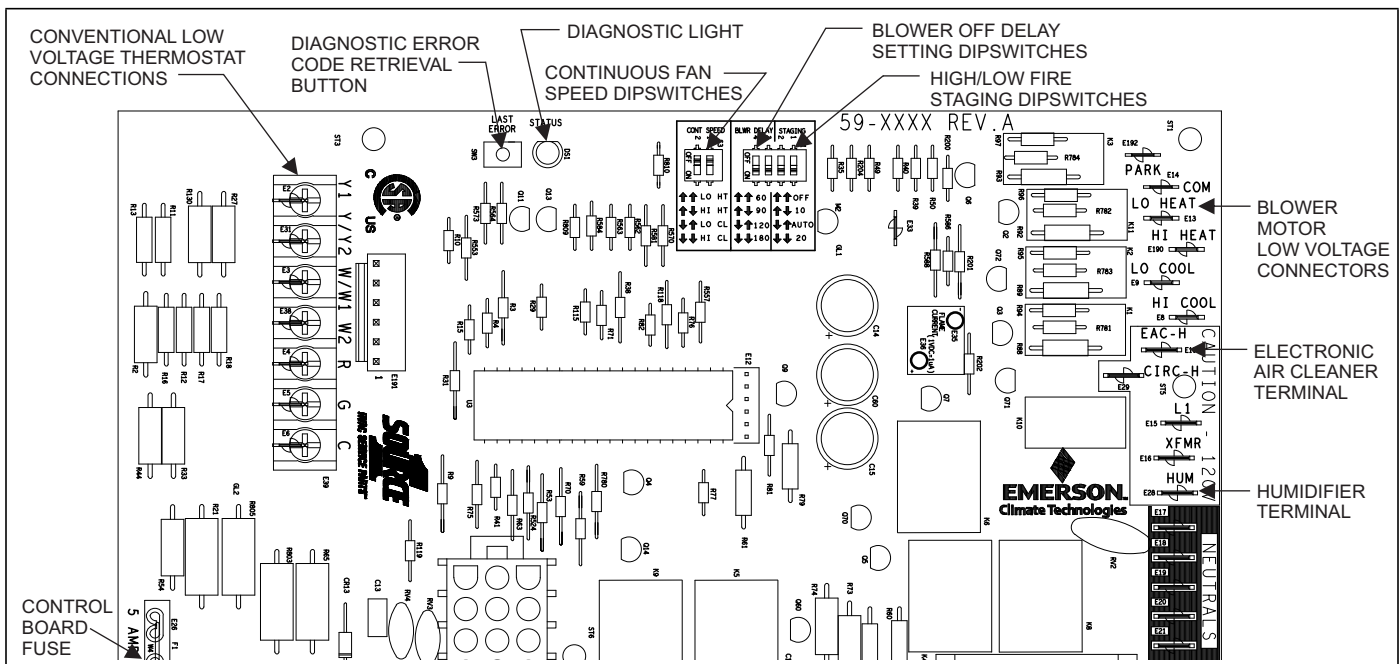

**FIGURE 19: Furnace Control Board**

**Table 14: Blower Performance CFM - Any Position (without filter)**

Models	Speed	Airflow Data (SCFM) <sup>1,2</sup>									
		Ext. Static Pressure (in. H <sub>2</sub> O)									
		0.1	0.2	0.3	0.4	0.5	0.6	0.7	0.8	0.9	1.0
060A12	High	1260	1220	1180	1150	1110	1070	1030	990	940	900
	Medium High	1160	1120	1080	1030	990	950	900	850	800	760
	Medium	1010	960	920	880	830	780	740	680	640	590
	Medium Low	860	810	770	710	670	580	560	510	460	410
	Low	800	760	710	650	610	550	500	460	390	350
080B12	High	1330	1300	1270	1240	1210	1160	1130	1090	1050	1000
	Medium High	1140	1100	1070	1020	990	950	900	850	800	760
	Medium	990	960	920	870	830	780	730	680	630	580
	Medium Low	920	890	840	790	740	700	640	600	550	510
	Low	820	770	730	680	630	580	540	480	430	390
080C16	High	1730	1700	1660	1610	1580	1520	1470	1410	1360	1300
	Medium High	1560	1530	1490	1450	1400	1350	1310	1270	1220	1170
	Medium	1370	1330	1280	1230	1180	1130	1080	1030	970	910
	Medium Low	1190	1140	1090	1040	990	930	870	820	750	680
	Low	1000	940	880	820	750	680	600	540	460	410
100C16	High	1730	1690	1650	1610	1570	1530	1470	1420	1360	1310
	Medium High	1570	1530	1490	1440	1400	1360	1320	1270	1220	1170
	Medium	1360	1310	1260	1220	1180	1130	1070	1010	950	890
	Medium Low	1210	1160	1110	1050	1000	940	880	810	760	700
	Low	1010	950	900	820	760	680	610	540	500	430
100C20	High	2230	2180	2130	2070	2020	1960	1900	1850	1790	1720
	Medium High	1820	1780	1740	1680	1620	1580	1530	1470	1410	1350
	Medium	1610	1550	1500	1440	1390	1340	1280	1230	1170	1110
	Medium Low	1440	1380	1320	1270	1210	1150	1090	1030	960	890
	Low	1210	1150	1080	1020	960	890	820	740	680	640
120C20	High	2150	2020	2040	1990	1930	1880	1820	1770	1720	1660
	Medium High	1780	1740	1690	1640	1590	1540	1490	1430	1380	1310
	Medium	1580	1520	1470	1420	1370	1320	1270	1220	1160	1090
	Medium Low	1410	1350	1290	1240	1180	1130	1070	1020	950	890
	Low	1190	1130	1060	1000	940	880	820	760	680	630

1. Airflow expressed in standard cubic feet per minute (SCFM).

2. Motor voltage at 115 V.

**Note:** Operation at external static pressure higher than rating on furnace data plate is not recommended.

#### EXTERNAL STATIC PRESSURE SETUP

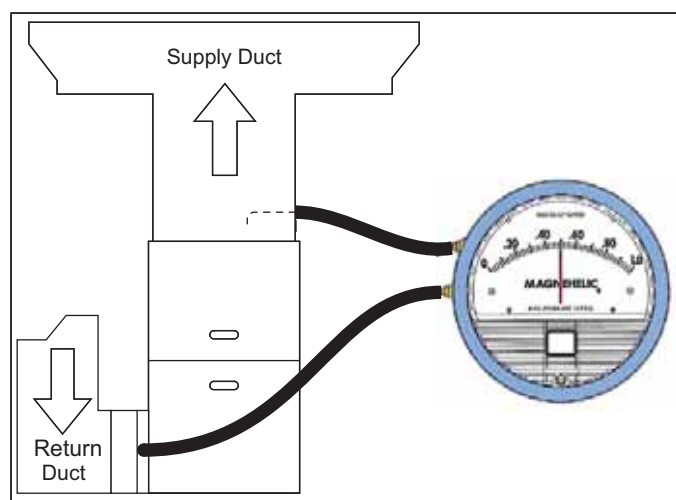

**FIGURE 20:** Measuring External Duct Static

Set appropriate airflow per temperature rise for gas heating. Set appropriate airflow per Table 13 for cooling/heat pump heating operating based on outdoor unit size.

#### To measure external static pressure:

- Measure the supply air static pressure
- Record this positive number
- Measure the return air static pressure
- Record this negative number
- Treat the negative number as a positive and add the two numbers together
- This is total system static

## SECTION IX: SAFETY CONTROLS

### CONTROL CIRCUIT FUSE

A 3-amp fuse is provided on the control circuit board to protect the 24-volt transformer from overload caused by control circuit wiring errors. This is an ATO 3, automotive type fuse and is located on the control board.

### BLOWER DOOR SAFETY SWITCH

#### ⚠ CAUTION

Main power to the unit must still be interrupted at the main power disconnect switch before any service or repair work is to be done to the unit. Do not rely upon the interlock switch as a main power disconnect.

Blower and burner must never be operated without the blower panel in place.

This unit is equipped with an electrical interlock switch mounted in the burner compartment. This switch interrupts all power at the unit when the panel covering the blower compartment is removed.

Electrical supply to this unit is dependent upon the panel that covers the blower compartment being in place and properly positioned.

### ROLLOUT SWITCH CONTROLS

These controls are mounted on the burner assembly. If the temperature in the area surrounding the burner exceeds its set point, the gas valve is de-energized. The operation of this control indicates a malfunction in the combustion air blower, heat exchanger or a blocked vent pipe connection. Corrective action is required. These are manual reset controls that must be reset before operation can continue.

### PRESSURE SWITCHES

This furnace is supplied with pressure switches, which monitor the flow through the combustion air/vent piping system. These switches de-energizes the gas valve if any of the following conditions are present.

1. Blockage of vent piping or terminal.
2. Failure of combustion air blower motor.

### LIMIT CONTROLS

There is a high temperature limit control located on the furnace vestibule panel near the gas valve. This is an automatic reset control that provides over temperature protection due to reduced airflow. This may be caused by:

1. A dirty filter.
2. If the indoor fan motor should fail.
3. Too many supply or return registers closed or blocked off.
4. Improperly sized duct system.

The control module will lockout if the limit trips 5 consecutive times. If this occurs, control will reset & try ignition again after 1 hour.

### SEQUENCE OF OPERATION

The following describes the sequence of operation of the furnace. Refer to Owners Manual for component location.

#### Continuous Blower

Cooling/heating thermostats have a fan switch that has an ON and AUTO position. In the ON position the thermostat circuit is completed between terminals R and G. The motor will operate continuously on the speed tap that is selected through dipswitches on the furnace control board. To obtain a different constant air circulation change dipswitches to assign another speed tap.

#### Intermittent Blower - Cooling

Cooling/heating thermostats have a fan switch that has an ON and AUTO position. In the AUTO position the thermostat circuit is completed between terminals R and G when there is a call for cooling. The motor will operate on the speed tap wire that is connected to the HI COOL or LO COOL cooling terminal on the control board depending on 24V thermostat input on the Y1 or Y/Y2. The fan off setting is fixed at 60 seconds to improve cooling efficiency.

### Heating Cycle

When the thermostat switch is set on HEAT and the fan is set on AUTO, and there is a call for heat, a circuit is completed between terminals R and W of the thermostat. When the proper amount of combustion air is being provided, the pressure switch closes, the ignition control provides a 17-second ignitor warm-up period, the gas valve then opens, the gas starts to flow, ignition occurs and the flame sensor begins its sensing function. The furnace fires on high fire for 10 seconds, then it switches to low fire unless there is a heating call present on W2. The blower motor energizes 30 seconds after the gas valve opens if a flame is detected. Normal furnace operation continues until the thermostat circuit between R and W is opened, which causes the ignition system and gas valve to de-energize and the burner flames to be extinguished. The vent motor operates for 15 seconds and the blower motor operates for the amount of time set by the fan-off delay dip switches located on the control board. See Figure 19. The heating cycle is now complete, and ready for the start of the next heating cycle.

If the flame is not detected within 7 seconds of the gas valve opening, the gas valve is shut off and a retry operation begins. During a retry operation, the vent motor starts a 15 second inter-purge and the ignitor warm-up time is extended to 27 seconds. If the flame is established for more than 10 seconds after ignition during a retry, the control clears the ignition attempt (retry) counter. If three retries occur during a call for heat, the furnace shuts down for one hour. If at the end of the one hour shut down there is a call for heat, the furnace initiates a normal start cycle. If the problem has not been corrected, the furnace is in lockout again after three retries.

A momentary loss of gas supply, flame blowout, or a faulty flame probe circuit results in a disruption in the flame and is sensed within 1.0 second. The gas valve de-energizes and the control begins a recycle operation. A normal ignition sequence begins after a 15 second inter-purge. If during the five recycles the gas supply does not return, or the fault condition is not corrected the ignition control lockout is for 60 minutes.

During burner operation, a momentary loss of power for 50 milliseconds or longer de-energizes the gas valve. When the power is restored, the gas valve remains de-energized, and the ignition sequence immediately restarts.

### Hot Surface Ignition System

#### ⚠ WARNING

##### HOT SURFACE IGNITION SYSTEM

Do not attempt to light this furnace by hand (with a match or any other means). There may be a potential shock hazard from the components of the hot surface ignition system. The furnace can only be lit automatically by its hot surface ignition system.

### TROUBLESHOOTING

The following visual checks should be made before troubleshooting:

1. Check to see that the power to the furnace and the ignition control module is ON.
2. The manual shut-off valves in the gas line to the furnace must be open.
3. Make sure all wiring connections are secure.
4. Review the sequence of operation. Start the system by setting the thermostat above the room temperature. Observe the system's response. Then use the troubleshooting section in this manual to check the system's operation.

#### ⚠ WARNING

**Never bypass any safety control to allow furnace operation. To do so will allow furnace to operate under potentially hazardous conditions.**

**Do not try to repair controls. Replace defective controls with UPG Source 1 Parts.**

**Never adjust pressure switch to allow furnace operation.**

## FURNACE CONTROL DIAGNOSTICS

The furnace has built-in, self-diagnostic capability. A blinking LED light on the control board can flash red, green or amber to indicate various conditions. The control continuously monitors its own operation and the operation of the system. If a failure occurs, the LED light will indicate the failure code.

The SLOW flash speed is two seconds on and two seconds off.

The other flash codes listed below have the following timing: LED light will turn on for 1/3 second and off for 1/3 second. This pattern will be repeated the number of times equal to the code. There will be a two-second pause between codes. For example, the six red flash code will flash the LED light on and off six times, then will be off for two seconds. This pattern will repeat as long as the fault condition remains. The continuous flash codes listed below will flash the LED light on and off continuously, with no breaks or longer pauses.

**SLOW GREEN FLASH:** Normal operation, no thermostat calls.

**SLOW AMBER FLASH:** Normal operation with call for heat.

**LED STEADY OFF** – If the LED light does not flash at all, check for power to the board and check for a blown fuse on the board. If the board is properly powered and the fuse is not blown, the control board may need to be replaced.

**STEADY ON ANY COLOR:** Possible control failure. Remove and check the control voltage fuse. An open fuse will result in a steady red LED. Turn power to the furnace off and back on. If the fault code returns, disconnect all field thermostat wiring. Cycle power off and back on. If fault code returns the control board must be replaced. The control board is not field-repairable.

**CONTINUOUS AMBER FLASH:** Flame sense current is below 0.28 microamps. Check and clean flame sensor. Check for proper gas flow. Verify that voltage is greater than 0.28 VDC at flame current test pad on furnace control board.

**1 RED FLASH:** This indicates that flame was sensed when there was not a call for heat. The control will turn on both the inducer motor and supply air blower. Check for a leaking or slow-closing gas valve.

**2 RED FLASHES:** This indicates that the pressure switch is closed when it should be open. The control confirms that the pressure switch contacts are open at the beginning of each heat cycle and will not let the ignition sequence continue if the pressure switch contacts are closed when they should be open. Check for a faulty pressure switch or miswiring.

**3 RED FLASHES:** This indicates the pressure switch contacts are open when they should be closed. Check for faulty inducer, blocked vent pipe, broken pressure switch hose, disconnected pressure switch or inducer wires or faulty pressure switch. Use manometer to verify vent pressure.

**4 RED FLASHES:** This indicates that the main limit switch has opened its normally closed contacts during a call for heat. The control will turn on the supply air blower and inducer. Check for a dirty filter, improperly sized duct system, incorrect blower speed setting, incorrect firing rate, loose limit switch wiring or faulty blower motor.

If the limit switch has not closed within five minutes, the control will assume that the blower is not functioning, will start a hard lockout and will begin to flash the 11 Red Flashes error code. If, after fifteen minutes, the main limit still has not closed, the control will assume that a manual-reset roll-out switch has opened and will begin to flash the 5 Red Flash error code. See the description of "5 Red Flashes" and "11 Red Flashes" below.

If the main limit switch opens five times within a single call for heat, the control will indicate 4 Red Flashes and will enter a one-hour soft lockout.

**5 RED FLASHES:** This fault is indicated if the limit circuit is open for more than fifteen minutes, usually indicating that a manual-reset roll-out switch has opened. Check for proper combustion air, proper inducer operation, and heat exchanger failure or burner problem. The control will enter a hard lockout and power will have to be cycled off and on to reset the control after the problem has been corrected.

**6 RED FLASHES:** This indicates that while the unit was operating, the pressure switch opened four times during the call for heat. Check for faulty inducer, blocked vent pipe or faulty pressure switch. The furnace will lock out for one hour and then restart.

**7 RED FLASHES:** This fault code indicates that the flame could not be established during three trials for ignition. Check that the gas valve switch is in the ON position. Check for low or no gas pressure, faulty gas valve, dirty or faulty flame sensor, faulty hot surface ignitor, loose wires or a burner problem. The furnace will lock out for one hour and then restart.

**8 RED FLASHES:** This fault is indicated if the flame is lost five times (four recycles) during the heating cycle. Check for low gas pressure, dirty or faulty flame sensor or faulty gas valve. The furnace will lock out for one hour and then restart.

**9 RED FLASHES:** Indicates reversed line voltage polarity, grounding problem or reversed low voltage transformer wires. Both heating and cooling operations will be affected. Check polarity at furnace and branch. Check furnace grounding. Check that flame probe is not shorted to chassis. The furnace will not start the ignition sequence until this problem is corrected.

**10 RED FLASHES:** Gas valve energized with no call for heat. The main blower and inducer blower will run and no ignition sequence will be started as long as this condition exists. Check gas valve and gas valve wiring.

**11 RED FLASHES:** This indicates that the limit circuit has remained open for more than five minutes and less than fifteen minutes. This condition is usually caused by a failed blower motor or blower wheel. The control will enter a hard lockout and power will have to be cycled off and on to reset the control after the problem has been corrected.

**13 RED FLASHES:** This fault code indicates that the 2nd stage (high) pressures switch is open with a call for 2nd stage heating (high fire) present. Check for faulty inducer, blocked vent pipe, broken or disconnected pressure switch hoses, disconnected pressure switch or inducer wiring or faulty pressure switch. Use manometer to verify vent pressure.

**4 AMBER FLASHES:** The control is receiving a "Y" signal from the thermostat without a "G" signal. The furnace will operate normally in both heating and cooling, but this fault code will be displayed in order to alert the user that there is a wiring problem. Verify that the "G" wire from the thermostat is connected properly.

**SOFT LOCKOUT:** This control includes a soft lockout that will reset automatically after one hour. This provides protection to an unoccupied structure if a temporary condition exists causing a furnace malfunction. An example of this is a temporary interruption in gas supply that would prevent the furnace from lighting. The control will keep trying to light each hour and will resume normal operation if the gas supply is restored.

**HARD LOCKOUT:** Some fault conditions result in a hard lockout, which requires power to the control to be turned off and then back on to reset the control. The control will not automatically restart.

### IGNITION CONTROL FLAME SENSE LEVELS

Normal flame sense current is approximately  
3.7 microamps DC ( $\mu\text{a}$ )

Low flame signal warning starts at 0.28 microamps.

Low flame signal control lockout point is  
0.16 microamps DC ( $\mu\text{a}$ )

## DIAGNOSTIC FAULT CODE STORAGE AND RETRIEVAL

The control in this furnace is equipped with memory that will store up to five error codes to allow a service technician to diagnose problems more easily. This memory will be retained even if power to the furnace is lost. **This feature should only be used by a qualified service technician.**

If more than five error codes have occurred within last 30 days, only the five most recent will be retained. The furnace control board has a button, labeled "LAST ERROR" that is used to retrieve error codes. This function will only work if there are no active thermostat signals. So any call for heating, cooling or continuous fan must be terminated before attempting to retrieve error codes.

To retrieve the error codes, push and release the LAST ERROR button. The LED on the control will then flash the error codes that are in memory, starting with the most recent. There will be a two-second pause between each flash code. After the error codes have all been displayed, the LED will resume the normal slow green flash after a five second pause. To repeat the series of error codes, push the button again.

If there are no error codes in memory, the LED will flash two green flashes. To clear the memory, push the LAST ERROR button and hold it for more than five seconds. The LED will flash three green flashes when the memory has been cleared, then will resume the normal slow green flash after a five-second pause.

## SECTION X: REPLACEMENT PARTS LIST

DESCRIPTION
<b>MOTOR</b>
MOTOR, DIRECT DRIVE BLOWER
BLOWER, COMBUSTION
<b>ELECTRICAL</b>
CAPACITOR, RUN
SWITCH, LIMIT
CONTROL, FURNACE
IGNITER
SENSOR, FLAME
SWITCH, PRESSURE
SWITCH, DOOR
TRANSFORMER
VALVE, GAS
CONTROL, TEMPERATURE
<b>AIR MOVING</b>
HOUSING, BLOWER
HOUSING, BLOWER w/WHEEL
WHEEL, BLOWER
<b>FABRICATED PARTS</b>
BAFFLE, FLUE
BURNER, MAIN GAS
BRACKET, IGNITER
SHELF, BLOWER
RAIL, BLOWER (2 Req'd)

DESCRIPTION (Continued)
<b>FABRICATED PARTS</b>
BRACKET, BLOWER TRACK (2 Req'd)
HEAT EXCHANGER ASS'Y
MANIFOLD, GAS
PAN, BOTTOM
PANEL, TOP
PANEL, DOOR (2 Req'd)
VENT PAN, COMBUSTION (w/Gasket)
PANEL, BLOCKOFF
LO-NOX SCREEN
<b>MISCELLANEOUS</b>
ORIFICE, BURNER (Natural #45)
SIGHT GLASS, OVAL (2 Req'd)
GASKET, FOAM (Door) (1.5 ft req'd)
GASKET, INTAKE PAN
PLUG, VENT HOLE
BRACKET, DOOR
WIRING HARNESS
FERRULE (3 Req'd)
GROMMET (3 Req'd)
MOTOR MOUNT
TUBING, SILICON
DIAGRAM, WIRING
KNOB, QUARTER TURN (4 Req'd)

---

## REPLACEMENT PART CONTACT INFORMATION

This is a generic parts list. To request a complete parts list, refer to the contact information below:

- Visit our website at [www.source1parts.com](http://www.source1parts.com) for the following information:
  1. Search for a part or browse the catalog.
  2. Find a dealer or distributor.
  3. Customer Service contact information.
    - a. Click on the "Brand Links" button
    - b. Click on the "Customer Service" button
- You can contact us by mail. Just send a written request to:

**Johnson Controls Unitary Products  
Consumer Relations  
5005 York Drive  
Norman, OK 73069**

---



## SECTION XI: WIRING DIAGRAM

## Wiring Diagram - 80% Two-Stage Standard ECM Furnace

**CAUTION**  
OPEN ALL DISCONNECTS BEFORE  
SERVICING THIS UNIT

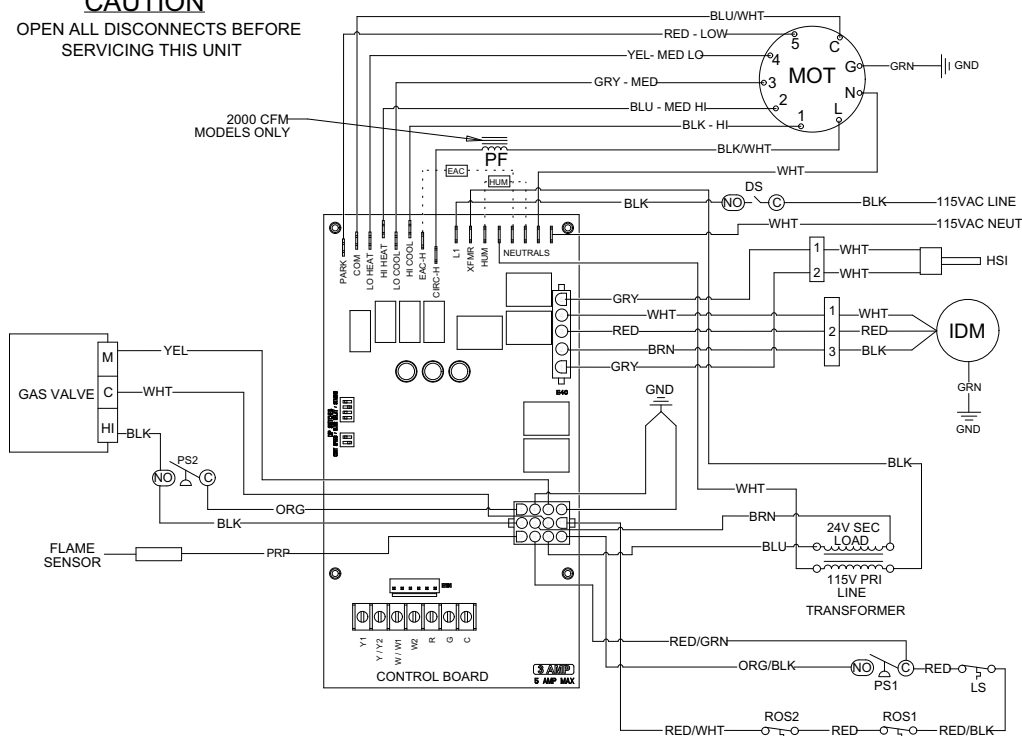

**PRECAUTION**  
OUVREZ LES DISJONCTEURS AVANT  
DE PROCEDER AVEC LE SERVICE

## Legend

DS - Door Switch  
EAC - Electronic Air Cleaner  
GV - Gas Valve  
HSI - Hot Surface Igniter  
HUM - Humidifier  
IDM - Inducer Motor  
LS - Limit Switch  
MOT - Circulating Motor  
PS1 - Pressure Switch 1 Stage  
PS2 - Pressure Switch 2 Stage  
ROS - Rollout Switch  
XFMR - Transformer  
PF - Power Factor Choke

## Legende

DS - Commutateur de porte  
EAC - Filtre électrique  
GV - Soupape de gaz  
HSI - Ignition de surface chaud  
HUM - Humidificateur  
IDM - D'induct moteur  
LS - Commutateur de limite  
MOT - Moteur soufflerie  
PS1 - Commutateur de pression, premier stage  
PS2 - Commutateur de pression, deuxième stage  
ROS - Commutateur de roulement  
XFMR - Transformeur  
PF - Transformeur e facteur de puissance

## Diagnostic Fault Codes

## Flashes

## Fault Condition

None	Power Off or blown fuse
Slow Green	Normal Operation
Slow Amber	Normal Operation with call for heat
Steady on Red	Open 24V control fuse OR Control Failure
Rapid Amber	Low flame sense current
4 Amber	Y signal with no G from thermostat
1 Red	Flame present with gas off
2 Red	Check pressure switch wiring
3 Red	Vent, intake, OR termination problem
4 Red	Airflow problem
5 Red	Flame Rollout
6 Red	Repeated 3 Red
7 Red	Failed to light burners
8 Red	Loss of flame during call for heat
9 Red	Hot/Neutral reversed OR poor ground/neutral
10 Red	Gas valve shorted "ON"
11 Red	Check blower motor/wiring
13 Red	Vent, intake, OR termination problem

Refer to Installation Manual for more detailed information.

## Fault Code Retrieval

Notice - Only a qualified service technician should use this feature.

Fault code retrieval functions will work only if there are no active thermostat signals.

To retrieve fault codes, push and release ERROR button on control board. The LED will flash the last five error codes, beginning with the most recent. If there are no fault codes in memory, the LED will give two green flashes. To clear the fault code memory, push and hold the ERROR button for at least five seconds. The LED will give three green flashes when the memory has been cleared.

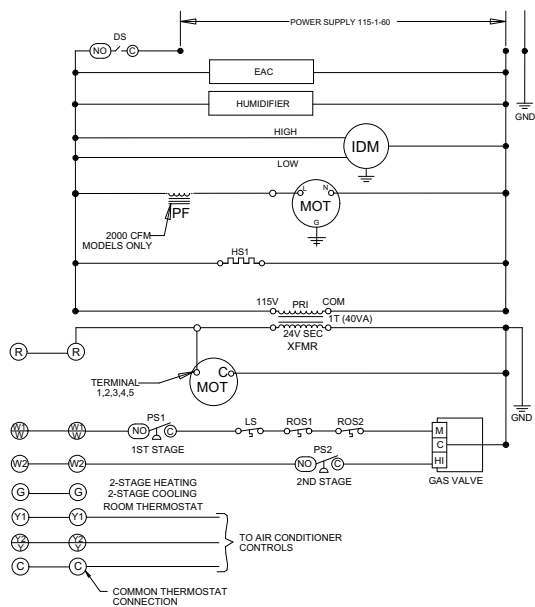

## NOTES:

- If any of the original wire as supplied with the furnace must be replaced, it must be replaced with wiring material having a temperature rating of at least 221 degrees F (105 degrees C).
- Blower motor speed connections shown are typical, but may vary by model and application.

## NOTES:

- Si l'un des fils d'origine fourni avec ce four doit être remplacé, il doit être remplacé avec le fil ayant un degré de température d'au moins 221 degrés F (105 degrés C).
- Les connexions à grande vitesse du moteur du ventilateur indiqués sont typiques, mais peuvent varier selon le modèle et par application.

5111808-UWD-E-0519

FIGURE 21: Wiring Diagram

## NOTES

## SECTION XII: START UP SHEET

## 33" 80% AFUE Two Stage Standard ECM Gas Furnace Start Up Sheet

Proper furnace start up is critical to customer comfort and equipment longevity

Start-Up Date

Technician Performing Start-Up

Installing Contractor Name

**Owner Information**

Name

Address

City

State or Province

Zip or Postal Code

**Equipment Data**

Furnace Model

Furnace Serial

Indoor Coil Model

Indoor Coil Serial

Outdoor Unit Model

Outdoor Unit Serial

**Furnace Configuration** Upflow Downflow Horizontal Left Horizontal Right**Filter, Thermostat, Accessories**

Filter Type

Filter Size

Filter Location(s)

Thermostat Type

Other System Equipment and Accessories

**Connections -- All Per Installation Instructions and Local Code** Unit is level Gas piping is connected (including drip leg) Supply plenum and return air are connected Vent system is connected**Venting: B Vent**

Vertical Termination

Vent Pipe Size

# of 90 Degree Ells

# of 45 Degree Ells

Total Height

Connector Size

Connector Length

 Horizontal Term. (with External Power Vent)

Vent Pipe Size

# of 90 Degree Ells

# of 45 Degree Ells

**Venting: Lined Masonry Chimney**

B Vent Connector

Single Wall Connector

Connector Size

Connector Length

Chimney Height

# of 90 Degree Ells

# of 45 Degree Ells

Other appliances in same common vent:

Water Heater  BTUH InputFan Assisted?  Y  NFurnace  BTUH InputFan Assisted?  Y  NOther  BTUH InputFan Assisted?  Y  N Venting system is the proper size, within the limitations of the chart in the installation instructions, properly connected to the furnace, and properly pitched**Electrical: Line Voltage**

Polarity is correct (black is L1 (hot), white is N (neutral))

Ground wire is connected

Line voltage to furnace (AC)

**Electrical: Low Voltage**

Thermostat wiring is complete

Thermostat heat anticipator set to .4 (6 cycle per hour for electronic thermostats)

Low voltage value between "R" and "C" on furnace control board (volts AC)

**Thermostat:**

Thermostat Staging:

 OFF 10 MIN 15 AUTO 20 MIN

Continued on next Page

**Gas Side**Gas Type  Natural Gas  LP Gas (Requires LP conversion kit)LP Gas Conversion Kit Part # Used  LP Conversion Kit Installed By Inlet Gas Pressure (in. w.c.)  Low Fire Manifold Gas Pressure (in. w.c.)  High Fire Manifold Gas Pressure (in. w.c.) Calculated input in btuh - clock the gas meter in high fire (Nat Gas Only)  Burner flame inspected -- flames are blue and extending directly into the primary heat exchanger cells**Air Side: System External Static Pressure**Supply static before indoor coil (in w.c.)  Supply static after indoor coil (in w.c.) Return Static (in w.c.) before filter  Return Static (in w.c.) after filter (furnace side) Total External Static Pressure **Air Side: Heating (STD ECM)**Low Heat Blower Speed Selected  1  2  3  4  5High Heat Blower Speed Selected  1  2  3  4  5Temperature rise in degrees F measured in low fire Temperature rise in degrees F measured in high fire **Air Side: Cooling (STD ECM)**Low Cool Blower Speed Selected  1  2  3  4  5High Cool Blower Speed Selected  1  2  3  4  5Cooling CFM delivery (use Blower Performance Data Chart) Hi  Low **Air Side: Continuous Fan (STD ECM)**Blower Speed Selected  Lo Heat  HI Heat  Lo Cool  Hi Cool**Cycle Test**

- Operate the furnace through several heating cycles from the thermostat, noting and correcting any problems
- Operate the furnace through continuous fan cycles from the thermostat, noting and correcting any problems
- Operate the furnace through cooling cycles (as applicable), noting and correcting any problems

**Clean Up** Installation debris disposed of and furnace area cleaned up?**Owner Education**

- Give owner the owner's manual provided
- Explain operation of system to equipment owner
- Explain the importance of regular filter replacement and equipment maintenance
- Explain thermostat use and programming (if applicable) to owner

**Additional Job Detail**