

INSTALLATION MANUAL

FULL-CASED UPFLOW/COUNTERFLOW FOR COOLING/HEAT PUMPS

MODELS: CF

FULL-CASED MULTI-POSITION FOR COOLING/HEAT PUMPS

MODELS: CM



LIST OF SECTIONS

GENERAL	1	REFRIGERANT LINE CONNECTION	10
SAFETY	1	COIL METERING DEVICES	11
COIL INSTALLATION	4	INSTRUCTING THE OWNER	15
DIRECT DUCT INSTALLATION (CF MODELS)	10	AIR SYSTEM ADJUSTMENT	15
DUCT CONNECTIONS	10	INSTALLATION VERIFICATION	17
CONDENSATE DRAIN CONNECTIONS	10		

LIST OF FIGURES

Pressure Check	2	CM Horizontal Right Application with Modular Air Handler	9
Component Location - Cased Coil CF Model	2	CM Horizontal Left Application with Modular Air Handler	9
Component Location - Cased Coil CM Model	4	Diverter Shroud Installation	10
Duct Flanges - Coils CF / CM	4	Vapor Line Grommet	11
Vertical Upflow Applications with Furnaces	4	Recommended Distributor Adjustment	12
Vertical Downflow Applications with Furnaces	4	Piston Installation	12
Vertical Upflow Applications with Modular Air Handlers	5	TXV Installation	13
Vertical Downflow Applications with Modular Air Handlers	5	TXV Bulb and Equalizer line Installations	13
Recommended Position of Coil to Install		Proper Bulb Location for TXV	13
Downflow/Horizontal Right Condensate Components	5	Vertical Temperature Bulb Orientation	13
Installation of Downflow Condensate Diverter Shields	6	CM "N" & "A" Coil 1	4
CM60C Horizontal Right Condensate Deflectors	6	Communicating Port of the ECM Modular Blower Control Board	14
CM60C Horizontal Right Coil Condensate Final Assembly	6	Communicating Port of the Furnace	14
Condensate Shield	7	Wiring Diagram - EEV	15
Horizontal Pan Adjustment Strap Hole Reference	7	Drain Traps	17
Coil Condensate Deflector Installation	8	Location of Coil Trapped and Plugged	
CM Horizontal Right Application with Furnace	9	Drain Connections with Furnace	18
CM Horizontal Left Application with Furnace	9	Location of Coil Trapped and Plugged	
		Drain Connections with Modular Air Handler	18

LIST OF TABLES

Dimensions - CF Upflow/Downflow Full Cased Coils	2	Horizontal Pan Strap Settings for Horizontal Left	8
Dimensions - CM Multi-position Full Cased Coils	3	Air Flow Data (CFM)	16
Coil Air Flow Limits	4	Air Flow Data (CFM)	17

We recommend that the user read all sections of this manual and keep the manual for future reference.

WARNING

Cancer and Reproductive Harm – www.P65Warnings.ca.gov

SECTION I: GENERAL

This instruction covers the installation of the following coils with furnaces or MP / ME / MVC modular air handlers.

The coils have sweat connect fittings. All coils are shipped with a low psi nitrogen holding charge. See Figure 1.

SECTION II: SAFETY



This is a safety alert symbol. When you see this symbol on labels or in manuals, be alert to the potential for personal injury.

Understand and pay particular attention to the signal words **DANGER**, **WARNING**, or **CAUTION**.

DANGER indicates an **imminently** hazardous situation, which, if not avoided, **will result in death or serious injury**.

WARNING indicates a **potentially** hazardous situation, which, if not avoided, **could result in death or serious injury**.

CAUTION indicated a potentially hazardous situation, which, if not avoided may result in minor or moderate injury. It is also used to alert against unsafe practices and hazards involving only property damage.

WARNING

Improper installation may create a condition where the operation of the product could cause personal injury or property damage.

Improper installation, adjustment, alteration, service or maintenance can cause injury or property damage. Refer to this manual for assistance or additional information, consult a qualified installer or service agency.

CAUTION

This product must be installed in strict compliance with the enclosed installation instructions and any applicable local, state, and national codes including, but not limited to building, electrical, and mechanical codes.

⚠ WARNING

The furnace area must not be used as a broom closet or for any other storage purposes, as a fire hazard may be created. Never store items such as the following on, near or in contact with the furnace.

1. Spray or aerosol cans, rags, brooms, dust mops, vacuum cleaners or other cleaning tools.
2. Soap powders, bleaches, waxes or other Cleaning compounds; plastic items or containers; gasoline, kerosene, cigarette lighter fluid, dry cleaning fluids or other volatile fluid.
3. Paint thinners and other painting compounds.
4. Paper bags, boxes or other paper products.

Never operate the furnace with the blower door removed. To do so could result in serious personal injury and/or equipment damage.

INSPECTION

As soon as a coil is received, it should be checked to insure it is still under pressure per Figure 1. The coil should be inspected for possible damage during transit. If damage is evident, the extent of the damage should be noted on the carrier's delivery receipt. A separate request for inspection by the carrier's agent should be made in writing. See Local Distributor for more information. Check drain pan for cracks or breakage.

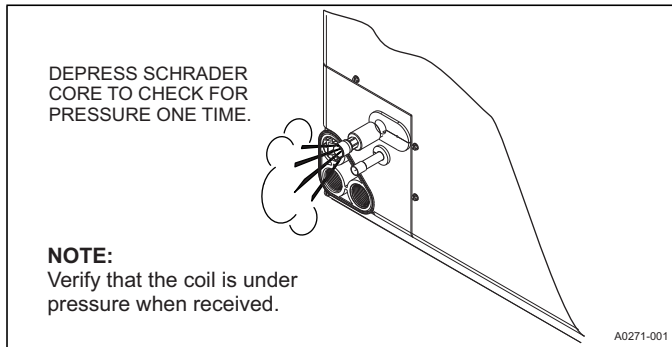

FIGURE 1: Pressure Check

CLEARANCES

During Installation

Dimensions for indoor coils are provided in Tables 1 and 2. Clearance must be provided for:

1. Refrigerant piping and connections
2. Maintenance and servicing access - including cleaning the coil
3. Condensate drain line
4. Removal of coil assembly

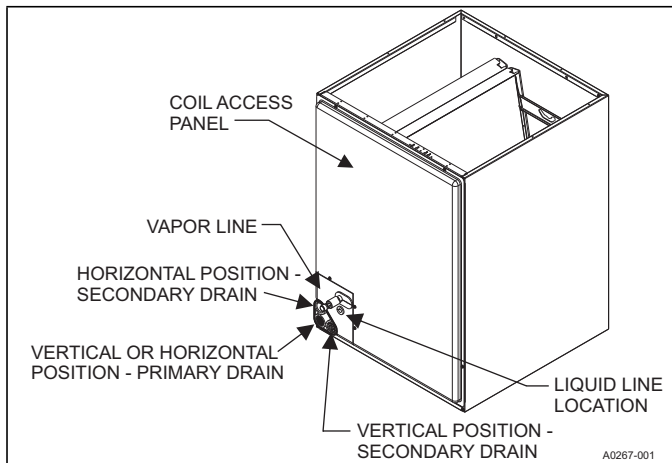

FIGURE 2: Component Location - Cased Coil CF Model

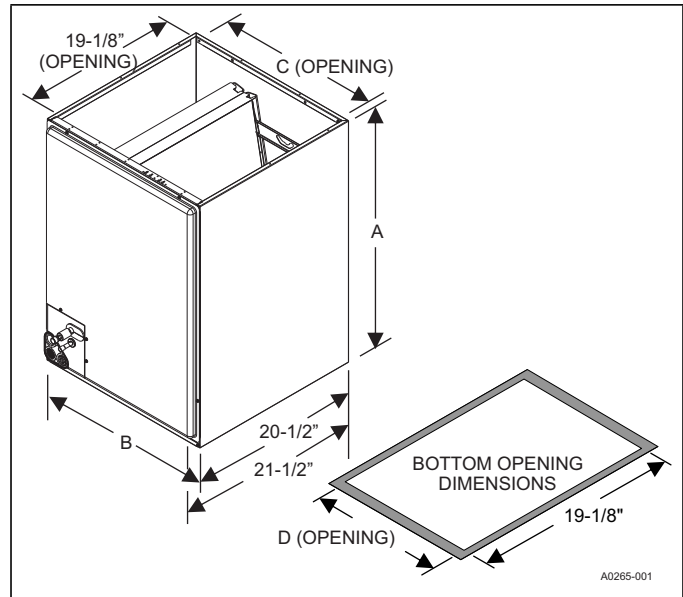
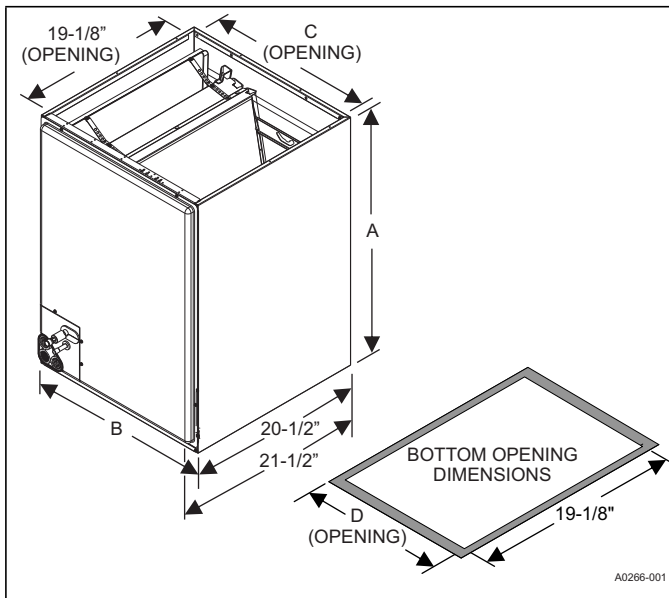

Table 1: Dimensions - CF Upflow/Downflow Full Cased Coils

Models ¹	Dimensions ²				Refrigerant Connections ^{3,4,5}	
	Height	Width	Opening Widths		Liquid	Vapor
	A	B	C	D		
CF18A*	19-1/2	14-1/2	13-1/2	13-1/2	3/8	3/4
CF18B	19	17-1/2	16-1/2	16-1/2		
CF24A*	19-1/2	14-1/2	13-1/2	13-1/2		
CF24B	19	17-1/2	16-1/2	16-1/2		
CF24C	21	21	20	20		
CF30A	21-5/8	14-1/2	13-1/2	13-1/2		
CF30B*	23	17-1/2	16-1/2	16-1/2		
CF30C	21	21	20	20		
CF30D	25	24-1/2	23-1/2	23-1/2		
CF36A	25-1/2	14-1/2	13-1/2	13-1/2		
CF36B*	25-5/8	17-1/2	16-1/2	16-1/2		
CF36C	23	21	20	20		
CF36D	25	24-1/2	23-1/2	23-1/2		
CF42B	25	17-1/2	16-1/2	16-1/2		
CF42C*	25	21	20	20		
CF42D	25	24-1/2	23-1/2	23-1/2		
CF48C*	27	21	20	20		
CF48D	27	24-1/2	23-1/2	23-1/2		
CF50C	37-1/4	21	20.0	20.0		
CF60C*	33	21	20	20		
CF61D	37-1/4	24-1/2	23-1/2	23-1/2		
CF60D	32-3/4	24-1/2	23-1/2	23-1/2		
CF64D	32-3/4	24-1/2	23-1/2	23-1/2		
					7/8	

1. (*) denotes coil model is available as a flex coil or with factory installed TXV.
2. All dimensions are in inches.
3. Refrigerant line sizes may require larger lines for extended line lengths. See Application Data part number 247077.
4. Adapter fitting must be field installed for other line set size.
5. See outdoor unit technical guide for proper line set size.

**Table 2:** Dimensions - CM Multi-position Full Cased Coils

Models ¹	Dimensions ²				Refrigerant Connections ^{3,4,5}	
	Height	Width	Opening Widths		Liquid	Vapor
	A	B	C	D		
CM18A*	19-1/2	14-1/2	13-1/2	13-1/2	3/8	3/4
CM18B	19	17-1/2	16-1/2	16-1/2		
CM24A*	19-1/2	14-1/2	13-1/2	13-1/2		
CM24B*	19	17-1/2	16-1/2	16-1/2		
CM24C	21	21	20	20		
CM25B#	25-5/8	17-1/2	16-1/2	16-1/2		
CM30A*	25-1/2	14-1/2	13-1/2	13-1/2		
CM30B*	23	17-1/2	16-1/2	16-1/2		
CM30C	23	21	20	20		
CM30D	25	24-1/2	23-1/2	23-1/2		
CM36A	25-1/2	14-1/2	13-1/2	13-1/2		
CM36B*	25-5/8	17-1/2	16-1/2	16-1/2		
CM36C*	25	21	20	20		
CM36D	25	24-1/2	23-1/2	23-1/2		
CM37B#	25-5/8	17-1/2	16-1/2	16-1/2		
CM37C#	25	21	20	20		
CM38C#	33	21	20	20		
CM42C*	27	21	20	20		
CM42D	27	24-1/2	23-1/2	23-1/2		
CM48C*	33	21	20	20		
CM48D*	32-3/4	24-1/2	23-1/2	23-1/2		
CM49C#	33	21	20	20		
CM49D#	32-3/4	24-1/2	23-1/2	23-1/2		
CM50C‡	37-1/4	21	20	20		
CM50D#	37-1/4	24-1/2	23-1/2	23-1/2		
CM60C*	33	21	20	20		
CM60D*	32-3/4	24-1/2	23-1/2	23-1/2		
CM61C#	37-1/4	21	20	20		
CM61D‡	37-1/4	24-1/2	23-1/2	23-1/2		
CM64D	32-3/4	24-1/2	23-1/2	23-1/2		
					7/8	

1. (*) denotes coil model is available as a flex coil or with factory installed TXV.

(#) denotes coils only available with factory mount EEV.

(‡) denotes coils only available with flex coil or factory mount EEV.

2. All dimensions are in inches.

3. Refrigerant line sizes may require larger lines for extended line lengths. See Application Data part number 247077.

4. Adapter fitting must be field installed for other line set size.

5. See outdoor unit technical guide for proper line set size.

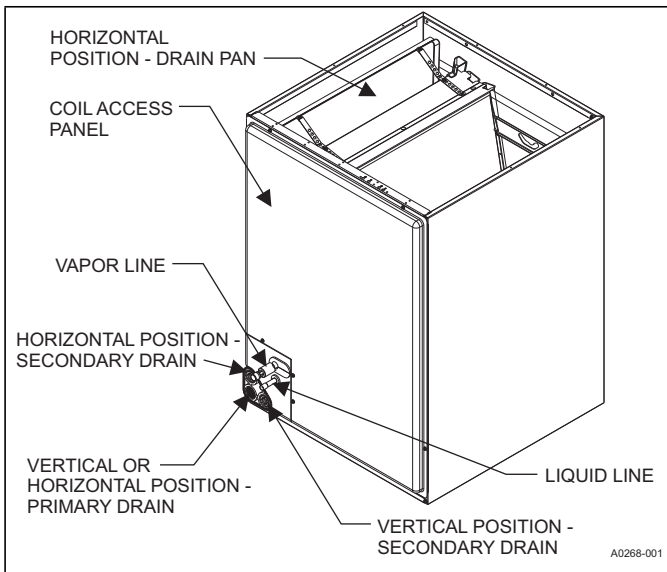

FIGURE 3: Component Location - Cased Coil CM Model

LIMITATIONS

These coils should be installed in accordance with all national and local safety codes. Refer to Table 3.

Table 3: Coil Air Flow Limits

Coil Size	Outdoor Unit Tons	CFM Limits	
		Minimum	Maximum
18	1-1/2	525	675
24	2	700	900
25	2	225	900
30	2-1/2	875	1125
36	3	1050	1350
37	3	325	1350
38	3	325	1350
42	3-1/2	1225	1575
48	4	1400	1800
49	4	425	1800
50	4	425	1800
60	5	1600	1800
60,64	5	1750	2250
61	5	500	2250

SECTION III: COIL INSTALLATION

DUCT FLANGES

Three duct flanges are provided to attach ductwork to the coil. The flanges are included in the parts bag along with three tie plates. Tie plates are used to secure the coil to the furnace or to the modular air handler as shown in Figures 4 - 8. Using the screws included in the parts bag, duct flanges are attached as shown in Figure 4 (to secure the duct to the coil). If the flanges are not used, they may be discarded.

NOTICE
For horizontal applications, the coil cabinet may be installed so that it is slightly pitched toward the front or drain connection end of coil.

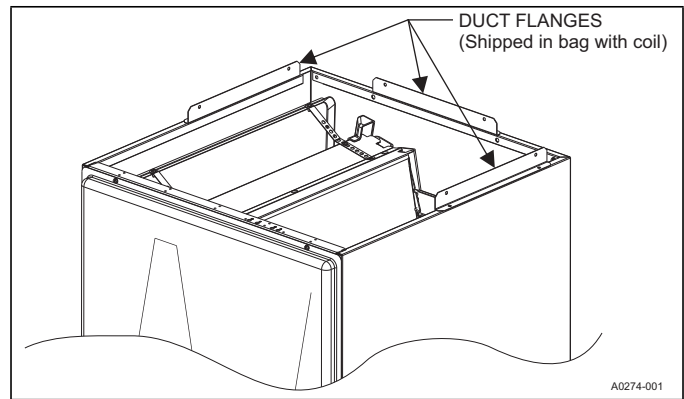

FIGURE 4: Duct Flanges - Coils CF / CM

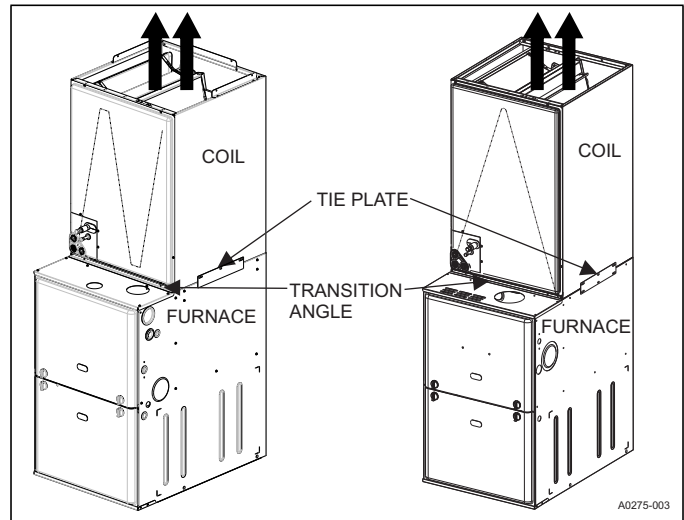

FIGURE 5: Vertical Upflow Applications with Furnaces

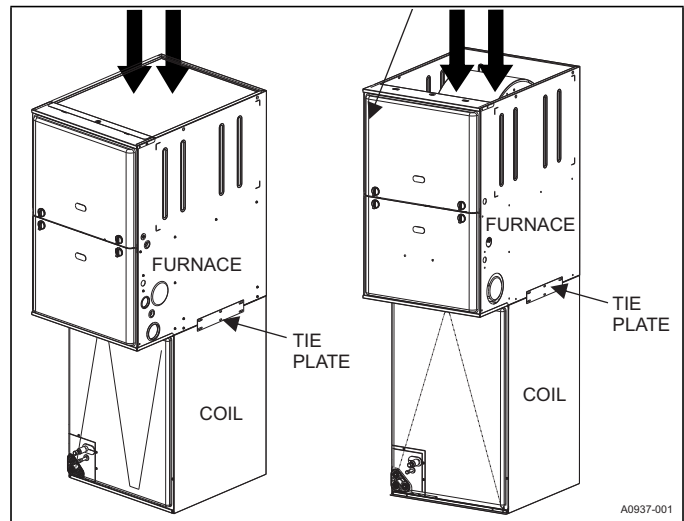

FIGURE 6: Vertical Downflow Applications with Furnaces

Handling CM Coil Applications when Removed from Casing:

When the CM coil assembly is removed from its casing, it must be handled in such a manner that does not compromise the foam gasket that seals the attachment point of the horizontal drain pan and primary drain pan. DO NOT position the coil so that the coil weight rests on the horizontal drain pan. By doing so, the horizontal drain pan straps could deform or become damaged which will not allow the pan to be positioned/angled correctly when the unit is horizontally installed, and if the foam gasket that seals the attachment point becomes compromised by the movement of the horizontal drain pan, condensate may leak at this point and cause damage to the unit/property.

Positioning the unit in horizontal applications:

Set unit so that it is sloped $\frac{1}{4}$ " towards the drain plug.

Downflow (CF/CM) or Horizontal Right (CM)

The coil cabinet has a factory installed transition angle on the bottom front side of the cabinet. For downflow and horizontal applications with a furnace, this angle must be repositioned to the top front side of the cabinet.

1. Remove two screws that fasten transition angle to bottom front of cabinet.
2. Remove two screws from top front side of cabinet.
3. Remove transition angle, rotate angle 180° end for end, and secure to top front side of cabinet.
4. For installation with modular air handling unit, remove the transition angle, and discard it.

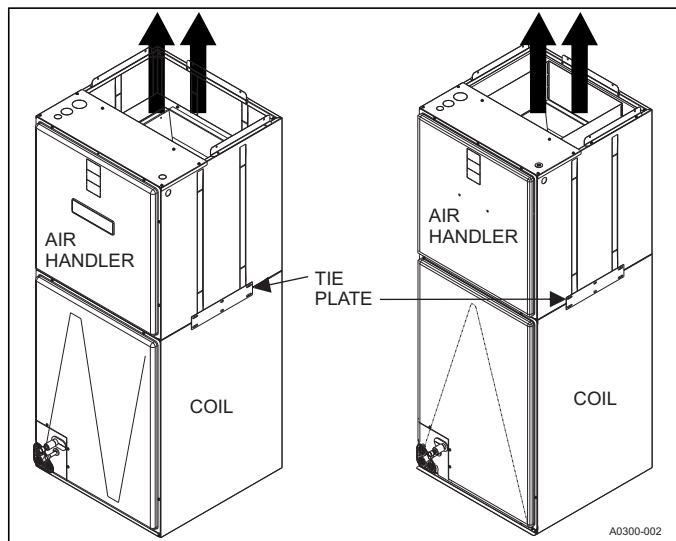

FIGURE 7: Vertical Upflow Applications with Modular Air Handlers

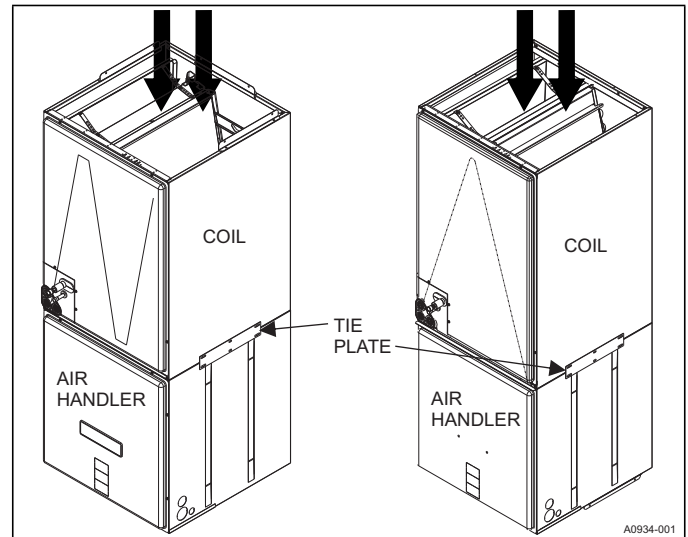

FIGURE 8: Vertical Downflow Applications with Modular Air Handlers

Downflow (CF/CM60C, D) or Horizontal Right (CM60C, D)

CF/CM60C, D are unique coil assemblies in that additional pieces are required to be installed in horizontal right and downflow applications to reduce the potential for condensate blow-off. The large cooling capacity and high volumetric airflow (1800 CFM and above) required for these coils put them more at risk of condensate blow-off. The installation of additional shields should mitigate condensate management issues while allowing the coil to perform adequately for proper cooling/heating. When installing any of the shield provisions, it is advised to position the coil such that the primary drain pan opening can be easily accessed to attach the shields (Figure 9).

IMPORTANT: DO NOT position the loose coil so that it rests on the horizontal drain pan. The weight of the coil will deform the horizontal pan straps, and the movement of the horizontal pan could potentially compromise the foam gasket that seals the horizontal drain pan to the primary drain pan. This could lead to water leaking at this attachment point and damaging the insulation/cabinet/property.



FIGURE 9: Recommended Position of Coil to Install Downflow/Horizontal Right Condensate Components

CF/CM60C, D Downflow

1. Attach the additional Downflow Condensate Shield (provided in the loose parts kit with this unit, and shown in Figure 13) to the primary drain pan underneath the coil slab by inserting the shield shown in Figure 10. Make sure that the shield is seated fully onto the primary drain pan.
2. Apply the foam gasket at the seam of the primary drain pan and the Downflow Condensate Shield. Make sure that the gasket material evenly covers the Downflow Condensate Shield and the primary drain pan.
3. When correctly installed, it should mirror the appearance of the factory installed Condensate Diverter Shield on the opposite side of the primary drain pan opening. See Figure 10.

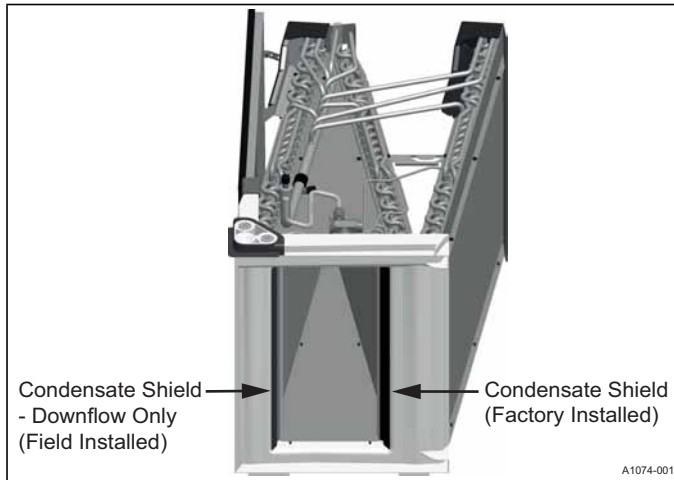

FIGURE 10: Installation of Downflow Condensate Diverter Shields

CM60C, D Horizontal Right

1. Attach the additional condensate deflectors (blow off wings) that were included in the loose parts kit to the coil assembly by loosening the screws that secure the front and rear delta plates to the primary drain pan. **DO NOT** remove the screws completely. Loosen them enough so that you can insert the deflectors between the drain pan and the delta plate.

IMPORTANT: FOR D-WIDTH (24.5") COIL ASSEMBLIES: The shields are symmetrical and will fit the same on the front and rear locations.
 FOR C-WIDTH (21.0") COIL ASSEMBLIES: While the shields may appear similar, they are actually different in that there is a front and rear shield. Due to their asymmetry, these shields will not fit correctly if they are oriented incorrectly. See Figure 11 for details.

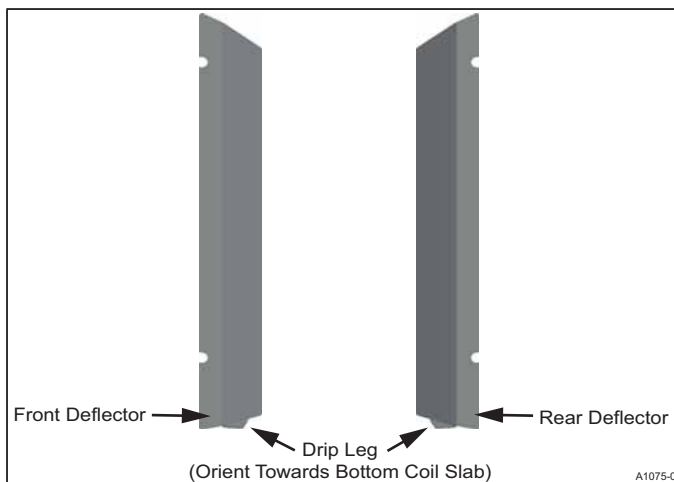

FIGURE 11: CM60C Horizontal Right Condensate Deflectors

2. Insert the deflectors between the primary drain pan and the delta plates. Make sure that the slots in the deflectors nest firmly against the loosened screws between the primary drain pan and delta plates.
3. Tighten the screws that secure the delta plates to the primary drain pan. The interactive fit of the delta plate, primary drain pan, and screws will hold the shields firmly in place during operation. Figure 12 shows the final assembly.



FIGURE 12: CM60C Horizontal Right Coil Condensate Final Assembly Upflow or Downflow Applications (CF/CM Models)

NOTICE

For maximum performance, if a CM coil is being installed in Upflow or Downflow orientation, it is recommended that the horizontal drain be removed from the assembly. This can be achieved by removing the horizontal drain pan support straps, cutting the foam gasket that seals the attachment point of the horizontal drain pan and primary drain pan, and removing the entire horizontal drain pan assembly.

These coils are factory shipped for installation in either upflow or downflow applications with a minor conversion.

DOWNFLOW CONVERSION CF/CM60 (C, D) models ONLY

Other models skip to step 5.

1. Rotate equipment cabinet so that the bottom of the primary (plastic) drain pan can be accessed.
2. Locate the downflow condensate shield (as shown in Figure 13) and foam gasket strip shipped in the loose parts kit included with the coil.

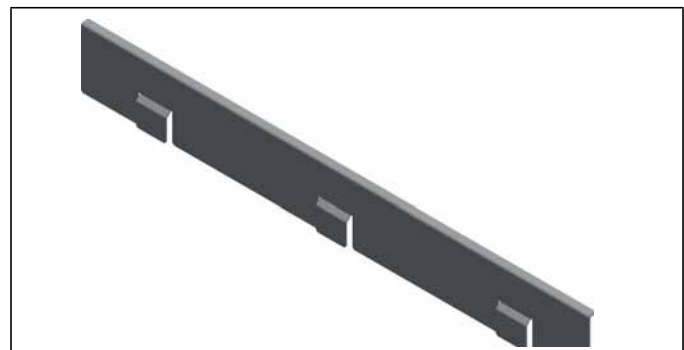

FIGURE 13: Condensate Shield

3. Install the condensate shield to the primary drain pan (as shown in Figure 10). There should be an identical condensate shield that was factory installed on the opposite side of the primary drain pan.
4. Apply the foam gasket strip to the condensate shield evenly so that it covers the condensate shield and primary drain pan.

DOWNFLOW CONVERSION all other models

- Place the three duct flanges (from bag with coil) in mounting positions of the upper air flow opening on the coil, and secure with screws from the bag as shown in Figure 4.
- See sections on “Refrigerant Line Connections” and “Condensate Drain Connections” for further installation instruction.

Horizontal Left Applications (CM Models only)

NOTICE
 For horizontal left applications, high airflow can prevent the collected condensate from draining properly since the direction of the airflow opposes the direction of the draining condensate. The horizontal pan must be angled properly in order to ensure proper drainage in high airflow applications. Ensure that the pan is angled properly by checking that the correct hole is used on the pan straps per TABLE 14. Use FIGURE 14 to identify the FRONT and REAR straps since, in some cases, these settings are not the same.

CM model coils are supplied ready to be installed in a horizontal left position. A horizontal drain pan is factory installed. If horizontal right application, refer to the horizontal right conversion before proceeding.

- Position the coil cabinet against the furnace or modular air handler opening as shown in Figure 5, 6, 7, or 8.
- Use the three tie plates and screws (included in bag with coil) to secure the coil cabinet to the furnace or modular air handler.
- Seal mating surfaces to prevent air leakage between the coil cabinet and the furnace or modular air handler.
- Install the three duct flanges with screws (from bag with coil) in positions shown in Figure 4.

See sections on “Refrigerant Line Connections” and “Condensate Drain Connections” for further installation instruction.

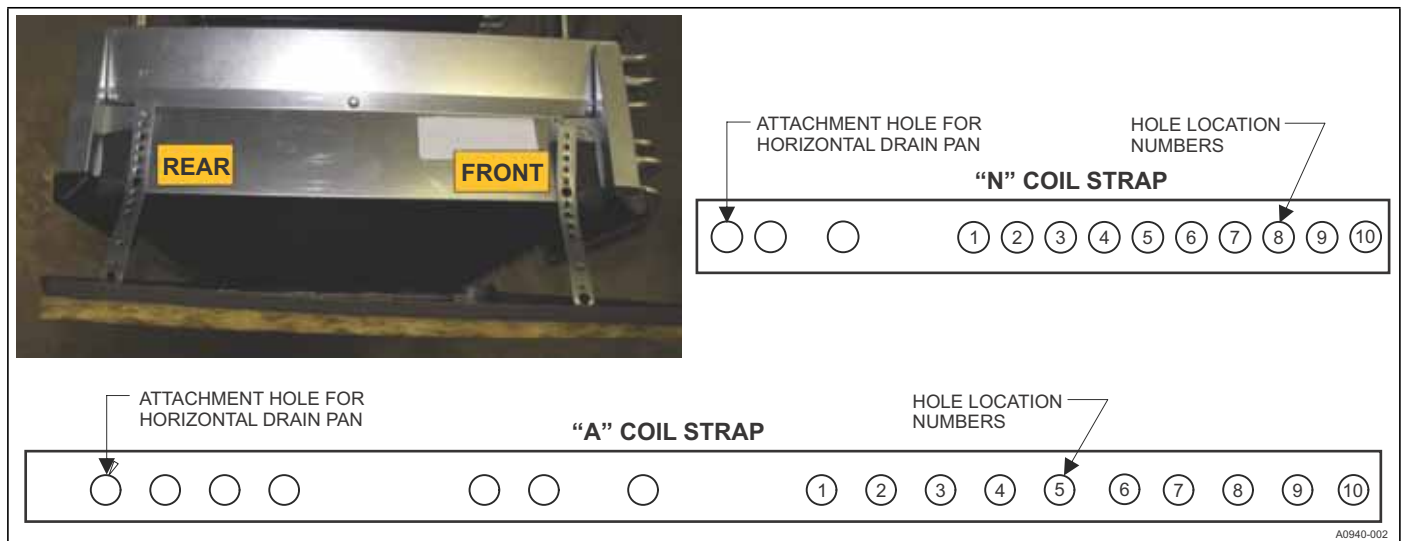

FIGURE 14: Horizontal Pan Adjustment Strap Hole Reference

Table 4: Horizontal Pan Strap Settings for Horizontal Left

Model	Back	Front
“N” Coils		
CM24A, CM24B, CM25B, CM30A, CM30B, CM36A, CM36B, CM37B	2	2
CM60C	3	4
CM42C, CM48C	4	4
CM64D	4	5
CM37C, CM30C, CM36C	5	5
CM24C	6	6
CM18B	7	7
CM30D, CM36D, CM42D, CM48D, CM60D	8	8
Model		
“A” Coils		
CM38C	1	1
CM49C	1	1
CM49D	6	5
CM50C	3	3
CM61C	3	3
CM50D	4	4
CM61D	4	4

Horizontal right applications - CM Model

NOTICE

Convert coil to correct orientation prior to installation. Conversion must be made before brazing the refrigerant connections to the coil.

NOTICE

No conversion necessary for CM "A" coils.

1. Remove coil access panel.

IMPORTANT: When the coil is removed from the cabinet, do not position the coil so that it rests on the horizontal drain pan. The horizontal pan is sealed to the primary pan with a foam gasket. The horizontal pan straps could bend and gasket could be compromised.

2. Slide coil/drain pan assembly out of coil cabinet.

NOTICE

When installing a coil condensate deflector, make sure that each notch in the coil condensate deflector slides around the anchor screw with the bottom of the notch fully set against the screw.

Ensure that each deflector is installed with the flange bending away from the coil delta plate. Front and rear condensate deflectors only apply to "N" coils.

3. Install the front and rear condensate deflectors (apply only to "N" coils) in accordance with the following:
 - a. Locate 4 screws (2 front side and 2 back side) securing the coil delta plates to the coil drain pan.
 - b. Loosen each screw.
 - c. Slide each coil condensate deflector between the drain pan and the coil delta plate.
 - d. Tighten screw to secure coil condensate deflectors. See Figure 15.

NOTICE

Condensate deflectors shipped with the 60C model coil are not identical. There is a separate front and rear part as shown in Figure 11. The drip leg section of each deflector should be directed toward the side of the coil that contains the horizontal drain pan.

4. Slide the coil back into the cabinet. Be sure to engage the side coil slide into the slide rail on the coil cabinet.
5. Install coil access panel. The horizontal right conversion is now complete. Return to and accomplish the horizontal application installation.

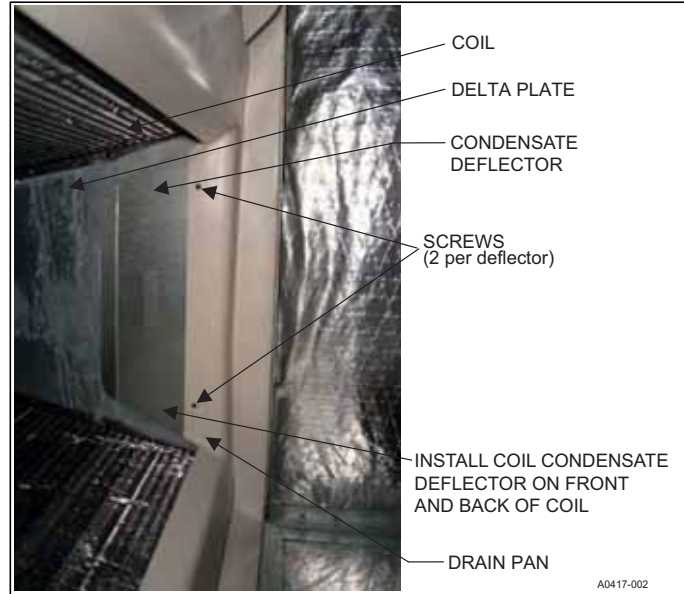

FIGURE 15: Coil Condensate Deflector Installation

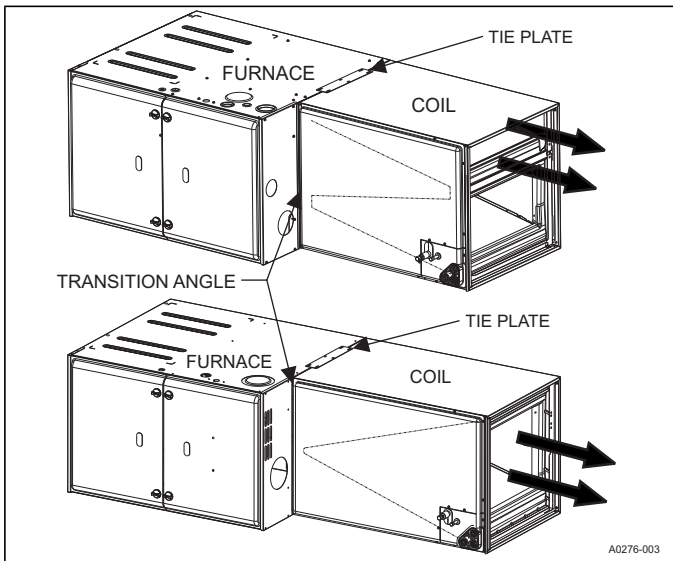

FIGURE 16: CM Horizontal Right Application with Furnace

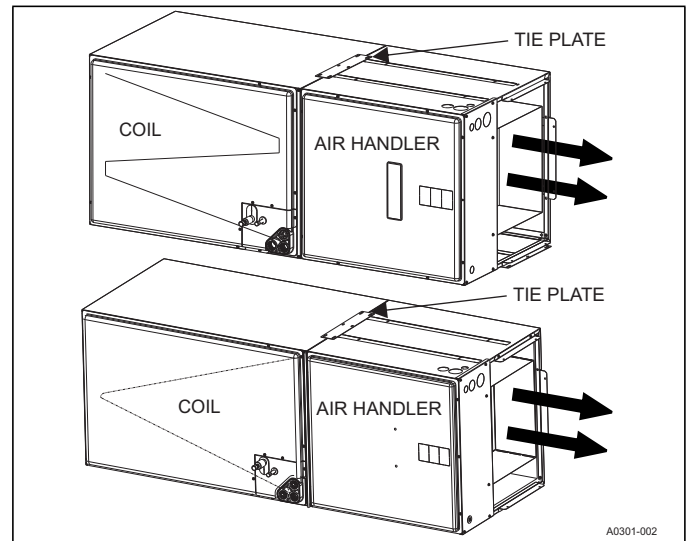

FIGURE 18: CM Horizontal Right Application with Modular Air Handler

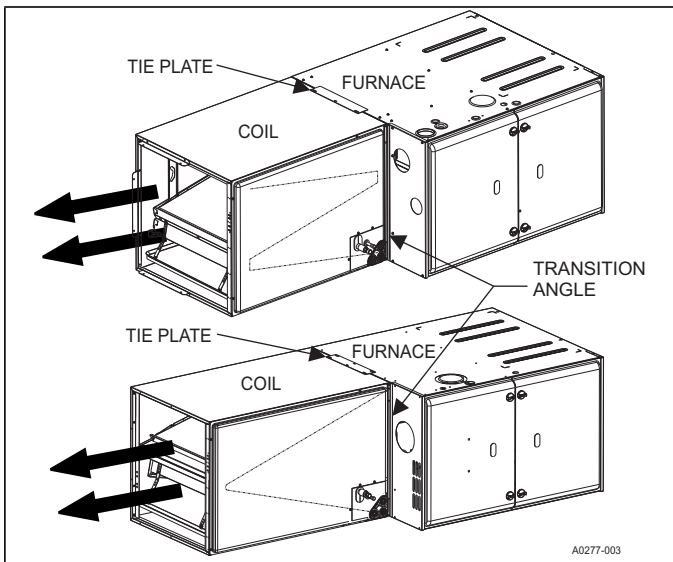

FIGURE 17: CM Horizontal Left Application with Furnace

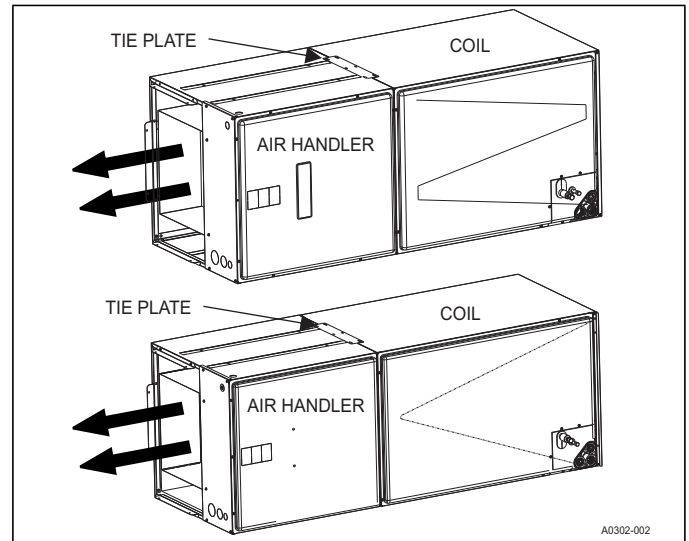

FIGURE 19: CM Horizontal Left Application with Modular Air Handler

SECTION IV: DIRECT DUCT INSTALLATION (CF MODELS)

In cases where the coil is being removed from the provided casing and installed directly into the ductwork, the shroud (a Source 1 part), must be installed. The top right blow off shield is removed, and the shroud is installed by attaching it to the top of the coil and to the front and aft seal plates. See Figure 20 for details.

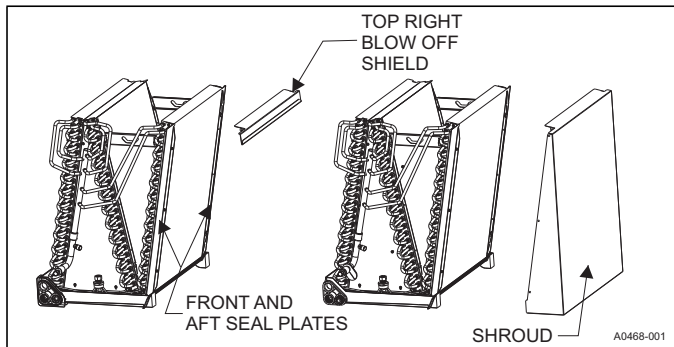

FIGURE 20: Diverter Shroud Installation

SECTION V: DUCT CONNECTIONS

Air supply and return may be handled in one of several ways best suited to the installation. Upflow, horizontal or downflow applications may be used.

The vast majority of problems encountered with heating and cooling systems can be linked to improperly designed or installed duct systems. To help ensure a successful installation, the duct system must be properly designed and installed.

Use flexible duct connectors to minimize the transmission of vibration/noise into the conditioned space.

⚠ WARNING

Use 1/2" screws to connect duct work to cabinet. If pilot holes are drilled, drill only through field duct and unit flange.

Where return air duct is short, or where sound may be a problem, acoustical duct liner should be used inside the duct. Insulation of duct work is a must where it runs through an unheated space during the heating season or through an uncooled space during the cooling season. The use of a vapor barrier is recommended to prevent absorption of moisture from the surrounding air into the insulation.

The supply air duct should be properly sized by use of a transition to match unit opening. All ducts should be suspended using flexible hangers and never fastened directly to the structure. Duct work should be fabricated and installed in accordance with local and/or national codes. This includes the standards of the National Fire Protection Association for Installation of Air Conditioning and Ventilating Systems, NFPA No. 90B.

⚠ CAUTION

Equipment should never be operated without filters.

SECTION VI: CONDENSATE DRAIN CONNECTIONS

All drain lines should be pitched 1/4-inch per foot away from unit drain pan and should be no smaller than the coil drain connection.

Route the drain line so that it doesn't interfere with accessibility to the coil, furnace, air handling system or filter and will not be exposed to freezing temperatures.

Instruct the owner that the indoor coil drain pan should be inspected and cleaned regularly to prevent odors and assure proper drainage.

NOTICE

When the coil is installed in an attic or above a finished ceiling, an auxiliary drain pan must be provided under the coil as is specified by most local building codes.

Coils should be installed level or pitched slightly toward the drain end. Suggested pitch should not exceed 1/4-inch per foot of coil.

Drain plugs can be removed using a standard 3/8" drive socket ratchet. If the coil is provided with a secondary drain it should be piped to a location that will give the occupant a visual warning that the primary drain is clogged. If a secondary drain is not used it must be plugged. See Figure 32 or 33.

⚠ CAUTION

Avoid Double Trapping.

⚠ CAUTION

Threaded drain connections should be hand tightened, plus no more than 1 turn.

DO NOT use Teflon™ tape, pipe thread compound, or other sealants. The use of a sealant may cause damage and premature failure of the drain pan.

NOTICE

If the coil is installed in a draw-thru application (modular air handler), the installer **MUST** trap the primary and secondary drain line. If the secondary drain line is not used, it must be plugged.

SECTION VII: REFRIGERANT LINE CONNECTION

⚠ CAUTION

Coil is under inert gas pressure. Relieve pressure from coil by depressing Schrader core at end of suction manifold stub out.

⚠ CAUTION

Dry nitrogen should always be supplied through the tubing while it is being brazed, because the temperature required is high enough to cause oxidation of the copper unless an inert atmosphere is provided. The flow of dry nitrogen should continue until the joint has cooled. Always use a pressure regulator and safety valve to insure that only low pressure dry nitrogen is introduced into the tubing. Only a small flow is necessary to displace air and prevent oxidation.

NOTICE

Avoid handling aluminum coil components after handling the copper line set or other tubing without first cleaning hands.

Connect lines as follows:**NOTICE**

Route the refrigerant lines to the coil in a manner that will not obstruct service access to the coil, air handling system, furnace flue or filter.

- Suction and liquid line connections are made outside the cabinet. Leave the tubing connection panel attached to the cabinet. Coil access panel should be removed for brazing. The lines are expanded to receive the field line set tubes for most outdoor unit matches.
- Remove grommets where tubes exit the cabinet to prevent burning them during brazing. In some units, the vapor line grommet may be shipped as a loose part with the unit. Refer to Figure 14.
- Cut the end of the suction tube using a tube cutter. Place the tube cutter as close as possible to the end of the tube to allow as much depth as possible for the connection and brazing of the suction line. To ensure suction line fits into connection, deburr the stub out (including inner pressure protrusion from cutting).
- If coil does not have a factory installed TXV or EEV, install the required size piston or TXV kit. See coil metering devices section for detailed instructions.
- If the coil does have a factory installed TXV or EEV, remove the liquid line copper cap which is soft soldered onto the outside of the 3/8" stub protruding from front of the coil cabinet tubing panel as follows:
 - Screw a sheet metal screw into the center of the cap.
 - Apply a small amount of heat to the cap while pulling on the screw using slip joint pliers.

IMPORTANT: FOR EEV EQUIPPED COILS ONLY

The EEV in this unit is shipped in the closed position to protect the valve during transportation. Prior to brazing, the following steps must be taken: 1. Connect the communication cable from the coil to the communication port on the furnace or modular blower control board. 2. Connect and apply line power to the field wiring terminals of the furnace or modular blower and ensure the board is powered for 60 seconds. This will ensure the EEV control board cycles the valve to an open position. This will allow nitrogen to flow through the system during brazing.

NOTICE

If power cannot be applied to the EEV control board prior to brazing refrigeration piping, a tool is available to manually operate the EEV. An EEV manual operating tool can be purchased from Source 1 as part number S1-02649686000. Six revolutions of the tool will open the valve fully.

- Insert liquid and suction lines into the coil connections at the coil cabinet tubing panel.
- Wrap a water soaked rag around the coil connection tubes inside the cabinet to avoid transferring excess heat to the coil, TXV, EEV and temperature sensor if EEV equipped.
- Purge refrigerant lines with dry nitrogen.

NOTICE

All indoor coil connections are copper-to-copper and should be brazed with a phosphorous-copper alloy material such as Silfos-5 or equivalent. DO NOT use soft solder.

- Braze the suction and liquid lines, and allow the joints to cool.
- If TXV is used, route the TXV sensing bulb through suction line opening. On EEV equipped coils, route the EEV control communicating cable through the suction line opening.
- Secure sensing bulb and equalizer line capillary tubes with nylon cable ties to prevent leaks from tubes rubbing.

- If piston is used, install Schrader core into suction header, and reinstall cap.
- Re-attach the grommets to the lines carefully to prevent air leakage. In some units, the vapor line grommet may be shipped as a loose part with the unit. Refer to Figure 21.
- Refer to Outdoor unit Installation Manual, and accomplish evacuation, leak check and charging instructions. Check all field brazed joints and metering device connections.
- Attach the coil access panel to the cabinet.
- Ensure lines are sound isolated by using appropriate hangers or strapping.

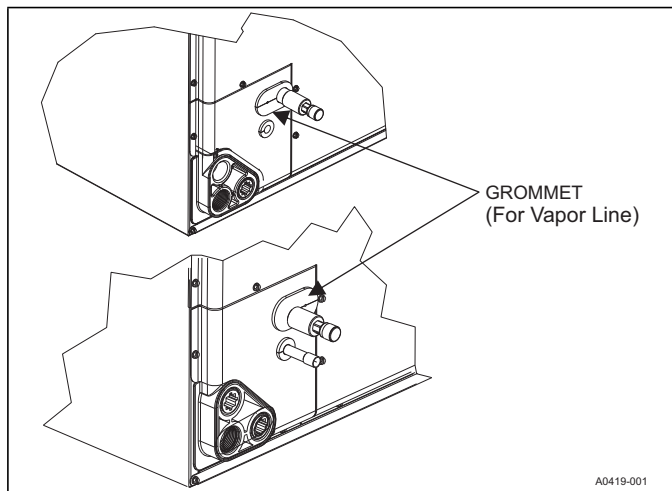
**FIGURE 21:** Vapor Line Grommet**SECTION VIII: COIL METERING DEVICES**

A piston or a TXV (flex coil models) is to be installed in the field. There is an installation manual that comes with the TXV kit. It is recommended to install the piston or TXV kit prior to installation of coil and brazing of line set. Until brazing is completed and cooled, the TXV sensing bulb must not be installed.

The outdoor technical guide for outdoor units should be consulted for required piston or TXV on the indoor coil. The piston and the Schrader core are supplied with the outdoor unit. If a piston is used in lieu of a TXV, the Schrader core must be installed in the suction line equalizer connection port and capped with the supplied plastic cap. The Schrader core must not be installed if the TXV is installed, as the TXV equalizer line attaches to the equalizer connection port.

CAUTION**COIL UNDER PRESSURE.**

Verify that pressure has been released by depressing Schrader valve core shown in Figure 1.

The coil requires a metering device to be added.

See outdoor unit documentation for correct TXV or piston to be used.

NOTICE

To prevent moisture and contaminants from entering the system, the coil should not be open to atmosphere for extended periods of time. If the coil cannot be brazed into the refrigeration system during a routine installation period, the ends should be temporarily closed or plugged. For a short term delay, use masking tape over the ends of the copper tubing to close the tube from the air. For a longer term delay, use plugs or caps. There is no need to purge the coil if this procedure is followed.

PISTON INSTALLATION

⚠ WARNING

Failure to install Schrader Valve Core in the vapor line equalizer connection port for piston applications could result in total refrigerant loss of the system!

Install Schrader Valve Core and Piston as follows:

1. After holding charge is completely discharged, remove black plastic cap from equalizer connection port on the vertical part of the vapor line.
2. Distributor position must be adjusted to allow the preformed liquid line assembly to properly line up with the hole in the tubing access panel. Raise the distributor body approximately 2" toward the top of the coil or what would be the top of the coil if coil was in the upflow position. See Figure 22. Adjust as necessary.
3. Install Schrader valve core supplied with the outdoor unit into the equalizer fitting connection port using a valve core tool.
4. Loosen and remove the liquid line connection nut and the sealing disc from the distributor assembly. Note that the fitting has right hand threads.
5. Slide the nut over the liquid line to be installed, and discard the seal disc.
6. Install required size piston into the distributor. Refer to supplied Tabular Data Sheet for specific piston size and indoor coil match up. See Figure 23.
7. Verify that the Teflon washer is still in place in the distributor opening. See Figure 23.

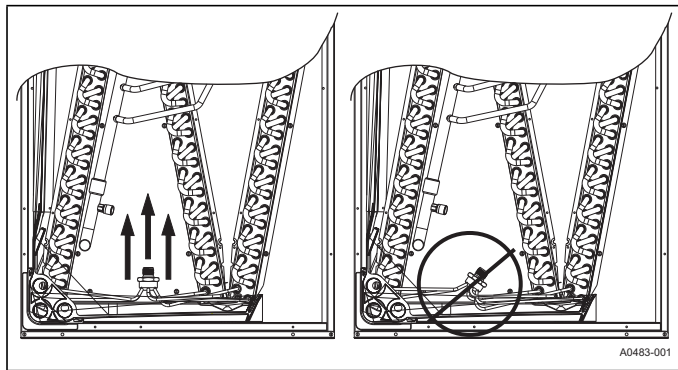

FIGURE 22: Recommended Distributor Adjustment

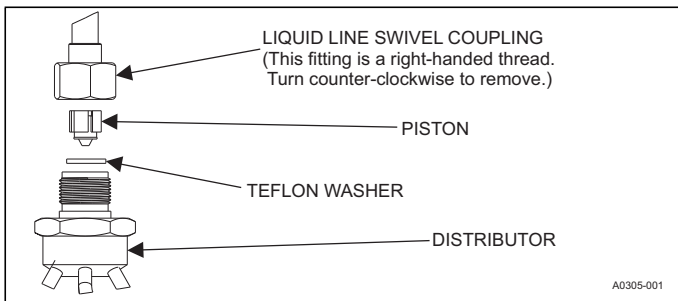

FIGURE 23: Piston Installation

⚠ CAUTION

Do not overtorque. Do not use slip joint pliers. This will distort the aluminum distributor and the brass fitting (potentially causing leaks).

8. After piston is installed, install the liquid line to the top of the piston/distributor assembly. Hand tighten, and turn an additional 1/4 turn to seal. Do not over tighten fittings.

9. Replace black plastic cap on unused equalizer fitting connection port.
10. After line set is installed, leak test the system.

THERMOSTATIC EXPANSION VALVE (TXV) INSTALLATION

⚠ CAUTION

Outdoor unit model numbers ending with an "H" have a factory installed hard start kit which is required when a TXV is installed. Outdoor unit model numbers with no "H" ending may require a hard start kit. See outdoor unit technical guide.

The following are basic steps for installation. For detailed instructions, refer to the Installation Instructions accompanying the TXV kit. Install TXV kit as follows:

IMPORTANT: Refer to the Technical Guide for the unit to determine the proper TXV kit to be used on this product.

1. Relieve the holding charge by depressing Schrader core on the suction manifold stub out.
2. After holding charge is completely discharged, loosen and remove the Schrader core.
3. Place a backup wrench on distributor, loosen and remove brass distributor nut. Retain brass nut for use on liquid line. Keep Teflon washer in place and discard sealing disk.
4. Install the thermal expansion valve to the distributor assembly with supplied fittings. Ensure Teflon washer is seated in distributor. Hand tighten and turn an additional 1/4 turn to seal. Do not over-tighten fittings. See Figure 24.

⚠ CAUTION

Do not over-torque. Do not use slip joint pliers. This will distort the aluminum distributor and the brass fitting (potentially causing leaks).

5. Slide the nut removed in step 3 over the supplied liquid line. Place supplied Teflon washer from TXV kit in place on TXV, and install liquid line to the top of the thermal expansion valve. Adjust assembly so liquid line aligns with hole in access panel. See Figure 24. Hand tighten the liquid line, and apply an additional 1/4 turn to seal.

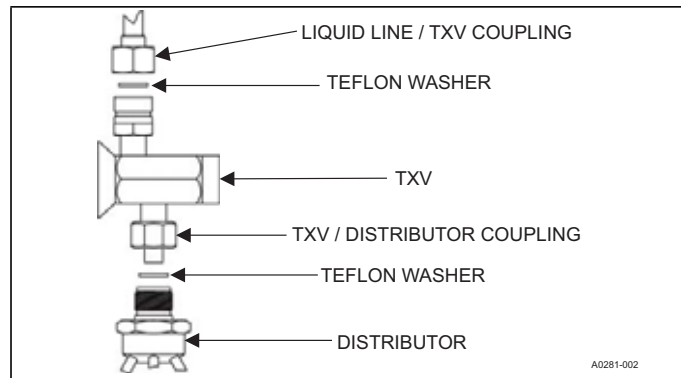

FIGURE 24: TXV Installation

⚠ WARNING

Schrader valve core **MUST NOT** be installed with TXV installation. Poor system performance or system failure could result.

6. Install the TXV equalizer line onto the vapor line by hand tightening the 1/4" SAE coupling nut to the equalizer fitting, and apply an additional 1/3 turn to seal. See Figure 25.

⚠ CAUTION

In all cases, mount the TXV temperature sensing bulb after vapor line is brazed and sufficiently cooled.

Failure to use suction line split grommet may result in TXV failure.

7. Pass the temperature sensing bulb tube for the TXV through the tube opening in the split grommet of the access panel.
8. Install the TXV bulb to the vapor line near the cabinet, using the bulb clamp(s) furnished with the TXV assembly. Ensure the bulb is making maximum contact. See Figures 25 and 26, and accomplish the following:
 - a. If possible, install the temperature bulb on a horizontal run of the vapor line. Ensure that the bulb is installed at a 10 o'clock or 2 o'clock position.
 - b. If bulb installation is made on a vertical run, ensure that the bulb is a minimum of 8 inches (20.3 cm) away from elbow coming out of the coil. Position the bulb with the tail of the bulb at the top, so that the bulb acts as a reservoir. See Figure 27.
 - c. Insulate the bulb using thermal insulation provided to protect it from the effect of the surrounding ambient temperature. Cover completely to insulate.

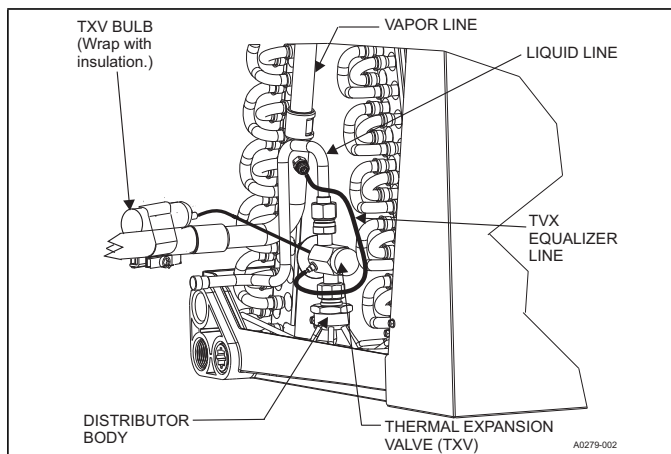

FIGURE 25: TXV Bulb and Equalizer line Installations

9. After line set is installed, leak test the system.

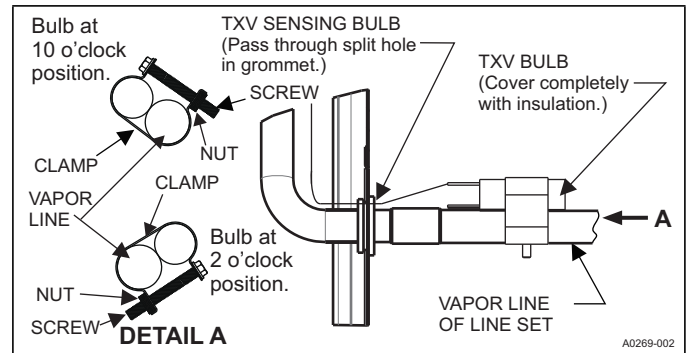

FIGURE 26: Proper Bulb Location for TXV

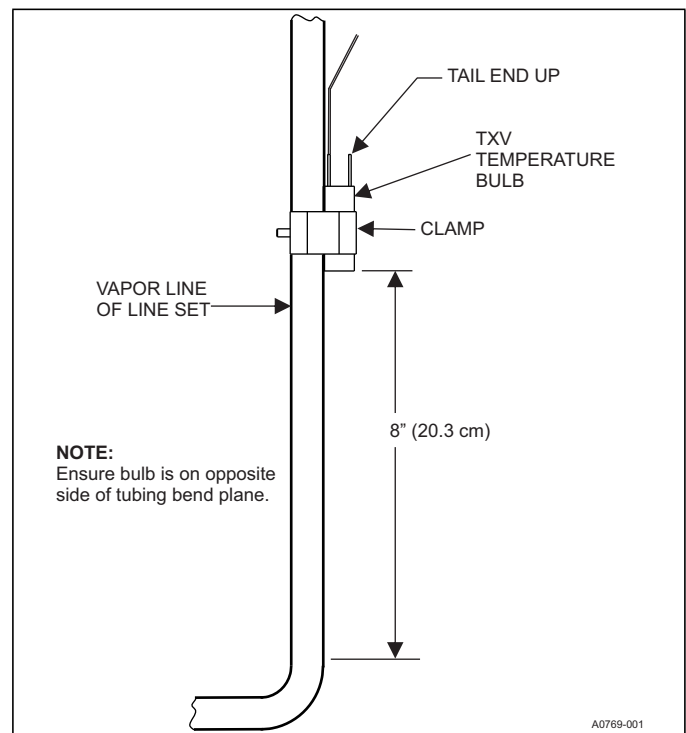

FIGURE 27: Vertical Temperature Bulb Orientation

ELECTRONIC EXPANSION VALVE (EEV) EQUIPPED COILS

Coils equipped with an EEV are available for use with a fully modulating matched system. The EEV and controls are factory installed. The installer only has to connect the included communication (4-wire) cable to the communicating 4-pin connector on the furnace or modular blower control board. See Figure 29 & 30 for connection diagrams and Figure 31 for wiring diagram.

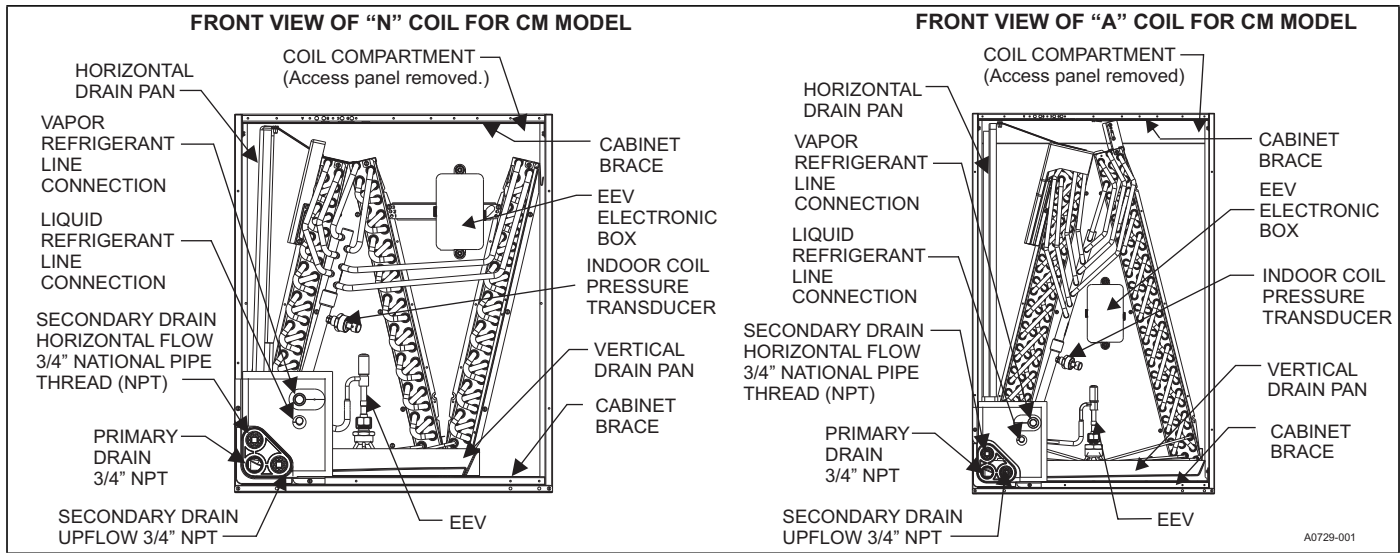

FIGURE 28: CM "N" & "A" Coil

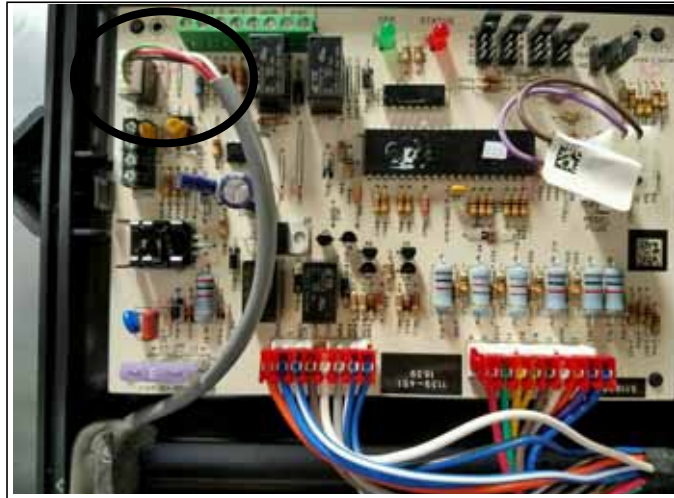

FIGURE 29: Communicating Port of the ECM Modular Blower Control Board

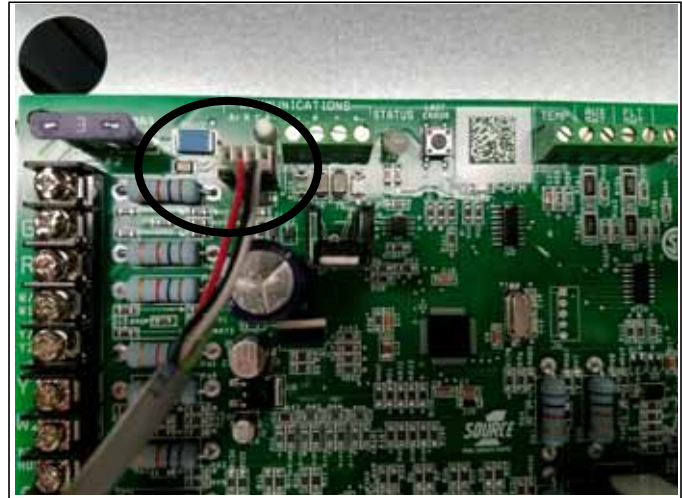

FIGURE 30: Communicating Port of the Furnace

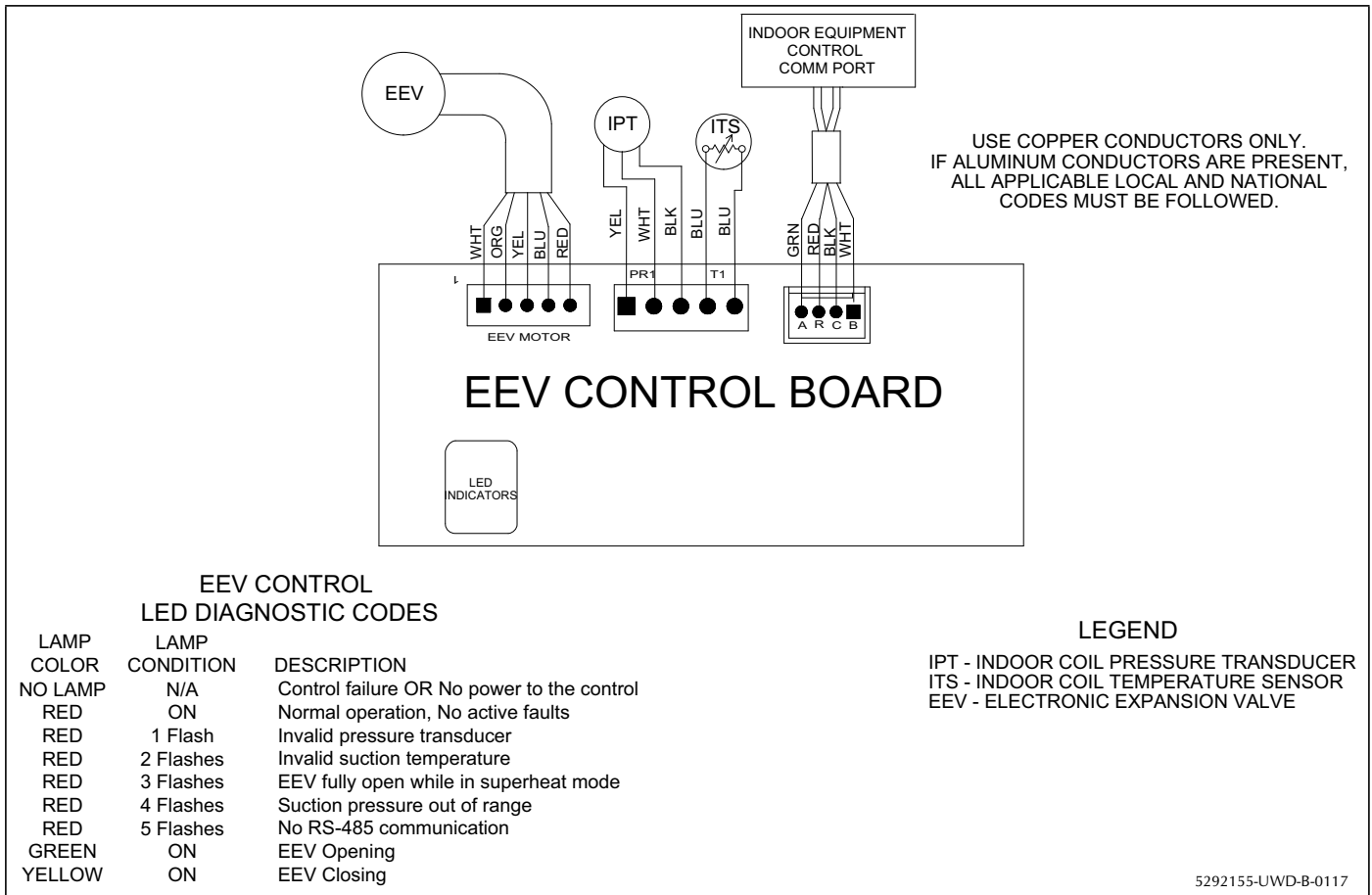

FIGURE 31: Wiring Diagram - EEV

COIL CLEANING

⚠ CAUTION

Ensure adequate precautions are taken to protect electrical components from liquid.

If the coil needs to be cleaned, it should be cleaned with water. As an alternative to water, EVAP-Green by Nu-Calgon is the only pH neutral coil cleaner approved to be used when it is properly diluted. ENSURE THE CLEANED COILS ARE THOROUGHLY RINSED AFTER USE OF EVAP-GREEN.

SECTION IX: INSTRUCTING THE OWNER

Assist the owner with registering the unit warranty using the warranty card included with the unit, or preferably online at www.upgproductregistration.com. It is strongly recommended to complete a startup sheet showing the critical readings of the unit at the time of commissioning, which can be uploaded as part of the online registration process.

SECTION X: AIR SYSTEM ADJUSTMENT

Refer to furnace or modular air handler instructions.

NOTICE

Tables 5 and 6 have DRY coil data. Run system indoor fan only for approximately 15 minutes prior to taking measurements to assure a dry coil.

Table 5: Air Flow Data (CFM)¹

Models	CFM										
	400	600	800	1000	1200	1400	1600	1800	2000	2200	2400
	External Static Pressure (in. wc.)										
CM18A	0.07	0.15	0.26	0.41	0.60	NA	NA	NA	NA	NA	NA
CM18B	0.04	0.08	0.14	0.21	0.30	0.41	0.52	NA	NA	NA	NA
CM24A	0.07	0.14	0.24	0.37	0.56	NA	NA	NA	NA	NA	NA
CM24B	0.02	0.05	0.13	0.21	0.28	0.37	0.49	NA	NA	NA	NA
CM24C	0.03	0.04	0.07	0.12	0.16	0.22	0.27	0.35	0.41	0.48	0.59
CM25B	0.02	0.08	0.15	0.20	0.29	0.39	0.50	NA	NA	NA	NA
CM30A	0.07	0.14	0.25	0.41	0.60	NA	NA	NA	NA	NA	NA
CM30B	0.03	0.07	0.12	0.21	0.30	0.40	0.52	NA	NA	NA	NA
CM30C	0.03	0.05	0.09	0.12	0.16	0.22	0.28	0.35	0.43	0.51	na
CM30D	0.04	0.03	0.06	0.09	0.12	0.15	0.19	0.24	0.29	0.34	0.40
CM36A	0.07	0.17	0.27	0.42	0.63	NA	NA	NA	NA	NA	NA
CM36B	0.02	0.08	0.15	0.20	0.29	0.39	0.50	NA	NA	NA	NA
CM36C	0.01	0.04	0.05	0.10	0.14	0.20	0.25	0.31	0.39	0.48	0.55
CM36D	0.04	0.04	0.06	0.08	0.11	0.15	0.18	0.23	0.27	0.33	0.38
CM37B	0.02	0.08	0.15	0.20	0.29	0.39	0.50	NA	NA	NA	NA
CM37C	0.01	0.04	0.05	0.10	0.14	0.20	0.25	0.31	0.39	0.48	0.55
CM38C	0.02	0.05	0.07	0.13	0.19	0.25	0.32	0.39	0.49	0.58	NA
CM42C	0.02	0.04	0.07	0.10	0.14	0.20	0.26	0.33	0.39	0.46	0.55
CM42D	0.03	0.03	0.05	0.07	0.10	0.13	0.17	0.21	0.25	0.31	0.37
CM48C	0.02	0.03	0.07	0.10	0.12	0.16	0.21	0.27	0.32	0.39	0.45
CM48D	0.02	0.03	0.05	0.06	0.11	0.13	0.17	0.20	0.25	0.29	0.35
CM49C	0.02	0.05	0.07	0.13	0.19	0.25	0.32	0.39	0.49	0.58	NA
CM49D	0.04	0.03	0.08	0.09	0.12	0.16	0.21	0.27	0.32	0.39	0.46
CM50C	0.03	0.05	0.09	0.14	0.19	0.25	0.32	0.41	0.50	0.60	NA
CM50D	0.02	0.04	0.06	0.11	0.16	0.20	0.26	0.32	0.38	0.48	0.55
CM60C	0.01	0.04	0.07	0.10	0.14	0.19	0.24	0.29	0.38	0.45	0.53
CM60D	0.02	0.03	0.06	0.06	0.08	0.12	0.15	0.19	0.23	0.28	0.34
CM61C	0.03	0.05	0.09	0.14	0.19	0.25	0.32	0.41	0.50	0.60	NA
CM61D	0.02	0.04	0.06	0.11	0.16	0.20	0.26	0.32	0.38	0.48	0.55
CM64D	0.03	0.04	0.06	0.10	0.15	0.19	0.25	0.31	0.38	0.47	0.55

1. Dry coil conditions only, tested without filters.

Table 6: Air Flow Data (CFM)¹

Models	CFM										
	400	600	800	1000	1200	1400	1600	1800	2000	2200	2400
	External Static Pressure (in. wc.) at noted CFM										
CF18A	0.05	0.12	0.21	0.32	0.48	0.64	NA	NA	NA	NA	NA
CF18B	0.02	0.08	0.12	0.17	0.24	0.32	0.42	0.52	NA	NA	NA
CF24A	0.05	0.12	0.19	0.31	0.46	0.62	NA	NA	NA	NA	NA
CF24B	0.03	0.07	0.15	0.16	0.24	0.32	0.40	0.51	NA	NA	NA
CF24C	0.03	0.04	0.07	0.10	0.14	0.20	0.25	0.31	0.38	0.46	0.53
CF30A	0.06	0.14	0.24	0.37	0.55	NA	NA	NA	NA	NA	NA
CF30B	0.05	0.07	0.11	0.16	0.22	0.30	0.39	0.49	0.60	NA	NA
CF30C	0.02	0.04	0.08	0.10	0.14	0.18	0.23	0.28	0.35	0.42	0.49
CF30D	0.03	0.04	0.07	0.08	0.11	0.13	0.18	0.22	0.26	0.31	0.36
CF36A	0.05	0.11	0.20	0.32	0.47	0.64	NA	NA	NA	NA	NA
CF36B	0.05	0.06	0.08	0.16	0.24	0.32	0.41	0.52	NA	NA	NA
CF36C	0.02	0.04	0.07	0.09	0.13	0.18	0.23	0.28	0.35	0.42	0.50
CF36D	0.02	0.04	0.04	0.06	0.09	0.12	0.16	0.20	0.24	0.28	0.33
CF42B	0.05	0.06	0.15	0.17	0.25	0.34	0.43	0.54	NA	NA	NA
CF42C	0.02	0.03	0.07	0.09	0.13	0.17	0.23	0.29	0.35	0.42	0.50
CF42D	0.03	0.03	0.07	0.06	0.09	0.12	0.15	0.19	0.23	0.27	0.32
CF48C	0.02	0.03	0.06	0.08	0.12	0.17	0.21	0.26	0.33	0.40	0.47
CF48D	0.02	0.03	0.04	0.06	0.09	0.12	0.15	0.19	0.23	0.27	0.33
CF50C	0.02	0.04	0.06	0.10	0.15	0.20	0.25	0.32	0.39	0.47	0.56
CF60C	0.01	0.03	0.07	0.09	0.13	0.18	0.23	0.28	0.35	0.43	0.49
CF60D	0.01	0.02	0.04	0.06	0.08	0.11	0.14	0.17	0.22	0.26	0.30
CF61D	0.02	0.04	0.06	0.07	0.10	0.13	0.17	0.21	0.27	0.32	0.37
CF64D	0.01	0.03	0.05	0.08	0.12	0.16	0.2	0.25	0.3	0.37	0.44

1. Dry coil conditions only, tested without filters.

SECTION XI: INSTALLATION VERIFICATION

Prior to and during the accomplishment of the installation procedures, verify all tasks are accomplished as illustrated in Figures 4 - 24.

THERMAL EXPANSION VALVE (TXV) CHECK LIST

- Is coil metering device installed correctly?
- Was correct TXV installed per the outdoor unit Technical Guide?
- Is TXV temperature bulb positioned correctly?
- Is TXV temperature bulb insulated?
- Is equalizer line connected?

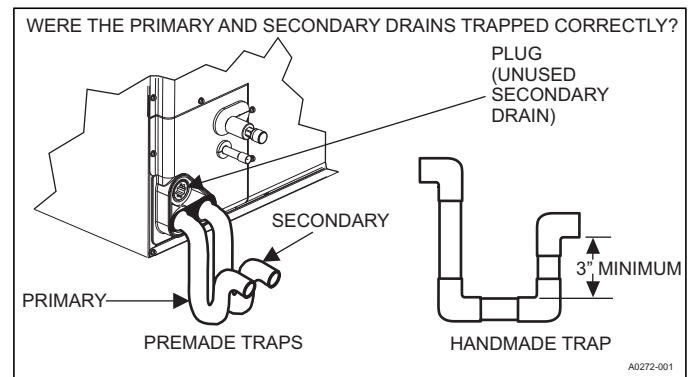

FIGURE 32: Drain Traps

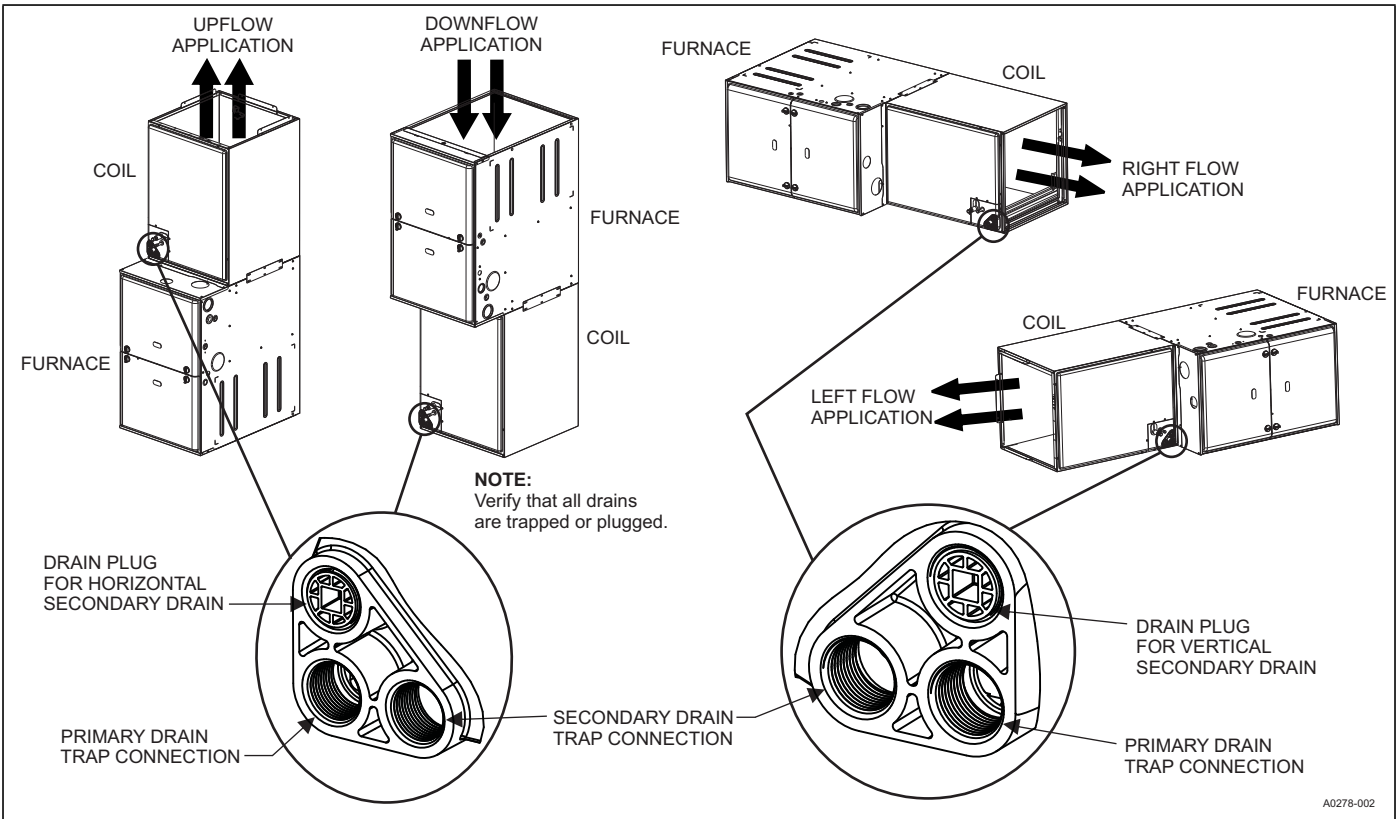

FIGURE 33: Location of Coil Trapped and Plugged Drain Connections with Furnace

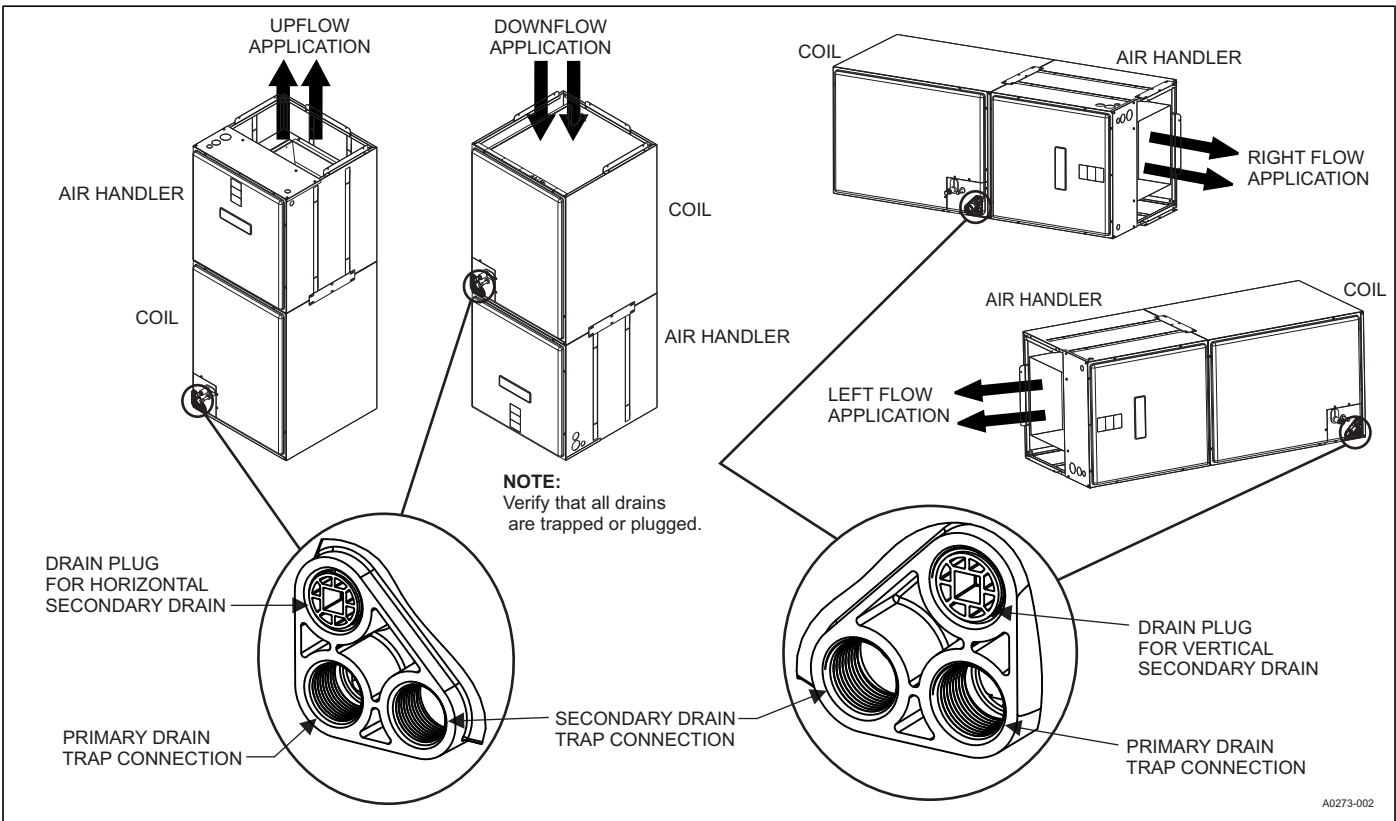

FIGURE 34: Location of Coil Trapped and Plugged Drain Connections with Modular Air Handler