

INSTALLATION MANUAL

**SINGLE PACKAGE
AIR CONDITIONER/ELECTRIC HEAT
MODELS: PCE4 SERIES
2 TON TO 5 TON - 208/230 V - 1 PHASE**



LIST OF SECTIONS

| | | | |
|---------------------------------|----|-------------------------------|----|
| GENERAL INFORMATION | 1 | OPERATION | 14 |
| SAFETY | 1 | MAINTENANCE | 15 |
| MODEL NUMBER NOMENCLATURE | 2 | TYPICAL WIRING DIAGRAMS | 16 |
| INSTALLATION | 2 | START-UP SHEET | 19 |
| AIRFLOW PERFORMANCE | 12 | | |

LIST OF FIGURES

| | | | |
|--|---|--|----|
| Component Location | 3 | Typical Field Power Wiring Diagram | 6 |
| Unit 4-Point Load Weight | 4 | Single-Point Wiring Kits | 10 |
| Unit Dimensions | 4 | Measuring External Static Pressure | 15 |
| Bottom Duct Dimensions (in.) | 5 | Connection Wiring Diagram | 16 |
| Rear Duct Dimensions (in.) | 5 | Ladder Wiring Diagram | 17 |
| Typical Field Control Wiring Diagram for Air Conditioner Models .. | 6 | R-410A Quick Reference Guide | 18 |

LIST OF TABLES

| | | | |
|--|---|--|----|
| Unit Limitations | 2 | Electric Heat Performance Data: 208/230-1-60 | 10 |
| Application Limitations | 3 | Single-Point Wiring Kits | 10 |
| Weights and Dimensions | 4 | Physical Data | 11 |
| Unit Dimensions | 4 | Airflow Performance - Side Duct Application | 12 |
| Unit Clearances | 5 | Electric Heat Minimum Supply Air | 13 |
| Electrical Data for 208/230-1-60 Single Source Power | 7 | Electric Heat Multipliers | 13 |
| Electrical Data for 208-1-60 Multi Source Power - PCE4 | 8 | Additional Static Resistance | 14 |
| Electrical Data for 230-1-60 Multi Source Power - PCE4 | 9 | Thermostat Signals | 14 |

SECTION I: GENERAL INFORMATION

PCE units are factory-assembled air conditioners designed for outdoor installation on a rooftop or a slab. Field-installed electric heater accessories are available to provide electric heat.

The units are completely assembled on rigid, removable base rails. All piping, refrigerant charge, and electrical wiring is factory installed and tested. The units require only electric power and duct connections at the point of installation.

SECTION II: SAFETY



This is a safety alert symbol. When you see this symbol on labels or in manuals, be alert to the potential for personal injury.

Understand and pay particular attention to the signal words **DANGER**, **WARNING**, or **CAUTION**.

DANGER indicates an **imminently** hazardous situation, which, if not avoided, **will result in death or serious injury**.

WARNING indicates a **potentially** hazardous situation, which, if not avoided, **could result in death or serious injury**.

CAUTION indicates a **potentially** hazardous situation, which, if not avoided **may result in minor or moderate injury**. It is also used to alert against unsafe practices and hazards involving only property damage.

WARNING

*Improper installation may create a condition where the operation of the product could cause personal injury or property damage. Improper installation, adjustment, alteration, service, or maintenance can cause injury or property damage. **Failure to carefully read and follow all instructions in this manual can result in furnace malfunction, death, personal injury, and/or property damage.** Only a qualified contractor, installer, or service agency should install this product.*

CAUTION

This product must be installed in strict compliance with the installation instructions and any applicable local, state, and national codes including, but not limited to building, electrical, and mechanical codes.

⚠ WARNING

Before performing service or maintenance operations on unit, turn off main power switch to unit. Electrical shock could cause personal injury. Improper installation, adjustment, alteration, service, or maintenance can cause injury or property damage. Refer to this manual. For assistance or additional information consult a qualified installer, service agency, or the gas supplier.

⚠ CAUTION

This system uses R-410A refrigerant, which operates at higher pressures than R-22. No other refrigerant may be used in this system. Gauge sets, hoses, refrigerant containers, and recovery systems must be designed to handle R-410A. If you are unsure, consult the equipment manufacturer. Failure to use R-410A compatible servicing equipment may result in property damage or injury.

Due to system pressure, moving parts, and electrical components, installation and servicing of air conditioning equipment can be hazardous. Only qualified, licensed service personnel must install, repair, or service this equipment. Unlicensed personnel can perform the basic maintenance functions of cleaning coils and filters and replacing filters.

Observe all precautions in the literature, labels, and tags accompanying the equipment when working on air conditioning equipment. Install this product in strict compliance with the installation instructions and any applicable local, state, and national codes including, but not limited to building, electrical, and mechanical codes.

Wear safety glasses and work gloves. Use quenching cloth and have a fire extinguisher available during brazing operations.

INSPECTION

On receiving a unit, inspect the unit for possible damage during transit. If damage is evident, note the extent of the damage on the carrier's freight bill. Make a separate request for inspection by the carrier's agent in writing.

REPLACEMENT PARTS

Contact your local Ducted Systems parts distribution center for authorized replacement parts.

SECTION III: MODEL NUMBER NOMENCLATURE

| PCE | 4 | A | 24 | | 2 | | 4 | A |
|--|---|---|----|---|---|---|---|---|
| 1 | 2 | 3 | 4 | 5 | 6 | 7 | 8 | 9 |
| 1. Model Family PCE - packaged A/C with electric heat PHE - packaged heat pump with electric heat PCG - packaged A/C with gas heat PHG - packaged heat pump with gas heat | | | | | 5. Gas Heating Input BTU/hr x 1000 050 = 50,000 BTU/hr input, blank = electric heat | | | |
| 2. Nominal Cooling Efficiency 4 = 14 SEER, 6 = 16 SEER | | | | | 6. Voltage-Phase-Frequency 2 = 208/230-1-60, 3 = 208/230-3-60, 4 = 460-3-60 | | | |
| 3. Cabinet Size A = small 35.75 x 51.25, B = large 45.75 x 51.25 | | | | | 7. NOx Approval X = low NOx, blank = not low NOx | | | |
| 4. Nominal Air Conditioning Cooling Capacity BTU/hr x 1000 24 = 24,000 BTU/hr, 30 = 30,000 BTU/hr | | | | | 8. Generation Level 1 = first generation, 2 = second generation | | | |
| Example: PCE4A2424A is a packaged A/C with electric heat, 14 SEER, small cabinet, 2 ton, 208/230 V, single-phase model, fourth generation, original release. | | | | | 9. Revision Level A = original release, B = second release | | | |

SECTION IV: INSTALLATION**LIMITATIONS**

Install these units in accordance with the following national and local safety codes:

- National Electrical Code ANSI/NFPA No. 70 or Canadian Electrical Code Part 1, C22.1 (latest editions)
- Local plumbing and wastewater codes and other applicable local codes

See Table 11 for unit physical data and Tables 6 to 9 for electrical data.

If it is necessary to add components to a unit to meet local codes, installation is done at the dealer's and/or customer's expense.

The size of the unit for proposed installation must be based on heat loss/heat gain calculations made in accordance with industry recognized procedures such as the Air Conditioning Contractors of America (Manual J).

Table 1: Unit Limitations

| Model | Unit Voltage | Unit Limitations | | |
|---------|--------------|------------------|---------|-----------------------------|
| | | Applied Voltage | | Outdoor DB Temperature (°F) |
| | | Minimum | Maximum | Maximum |
| PCE4A24 | 208/230-1-60 | 187 | 252 | 125 |
| PCE4A30 | 208/230-1-60 | 187 | 252 | 125 |
| PCE4A36 | 208/230-1-60 | 187 | 252 | 125 |
| PCE4A42 | 208/230-1-60 | 187 | 252 | 125 |
| PCE4B48 | 208/230-1-60 | 187 | 252 | 125 |
| PCE4B60 | 208/230-1-60 | 187 | 252 | 125 |

Table 2: Application Limitations

| Packaged Equipment Series | Air Temperature at Outdoor Coil (°F) | | Air Temperature at Indoor Coil (°F) | |
|---------------------------|--------------------------------------|---------|-------------------------------------|---------|
| | Minimum | Maximum | Minimum | Maximum |
| | DB Cool | DB Cool | WB Cool | WB Cool |
| 14 SEER AC | 55 | 125 | 57 | 72 |

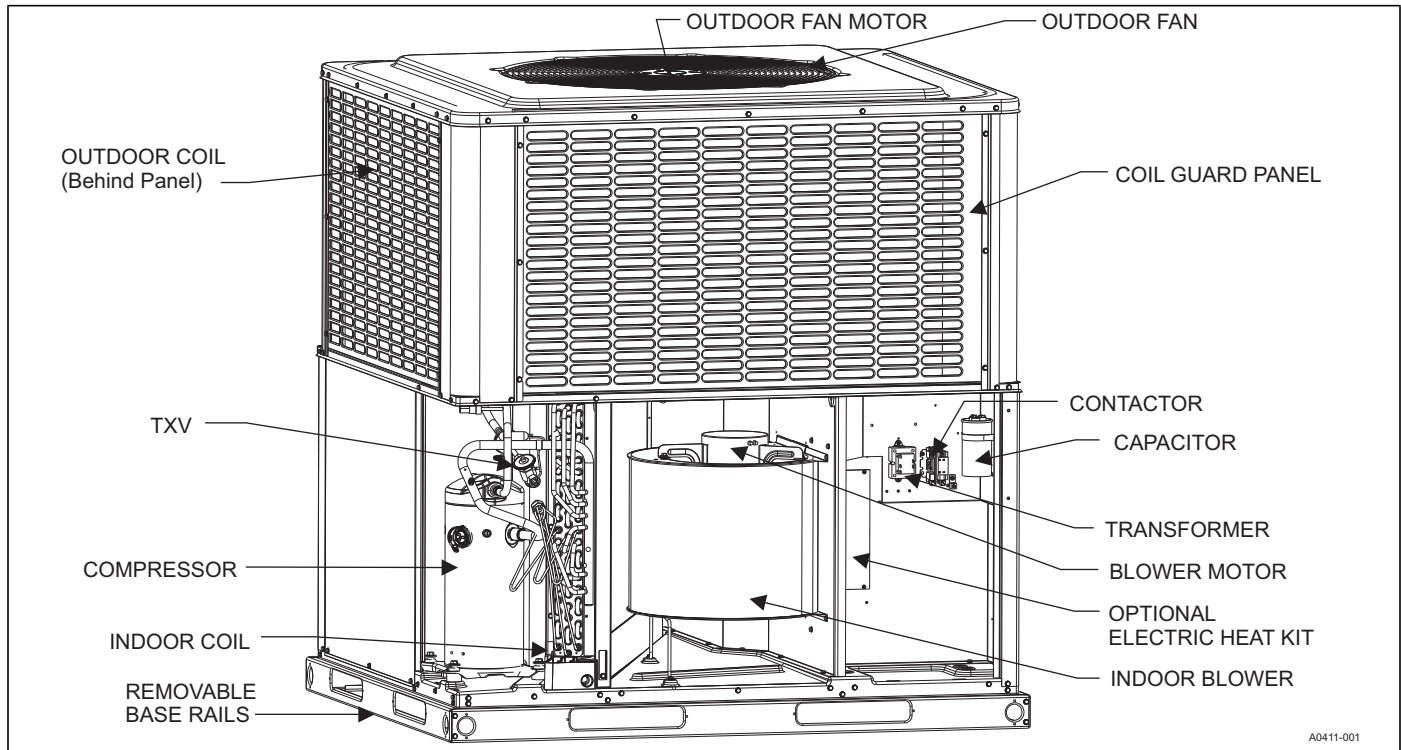

A0411-001

Figure 1: Component Location**LOCATION**

Use the following guidelines to select a suitable location for these units:

⚠ WARNING

Do not permit overhanging structures or shrubs to obstruct outdoor air discharge outlet.

- The unit is designed for **outdoor installation** only.
- Outdoor coils must have an unlimited supply of air. Where a choice of location is available, position the unit on either the north or east side of the building.
- The unit is suitable for mounting on a roof curb.

⚠ WARNING

Do not attach supply and return duct work to the bottom of the unit base pan as the drain pan could be compromised.

- For ground level installation, use a level pad or slab. The thickness and size of the pad or slab must meet local codes and support the weight of the unit. Do not tie the slab to the building foundation.
- Roof structures must be able to support the weight of the unit and its options/accessories. Install the unit on a solid, level roof curb or an appropriate angle iron frame.
- Maintain level tolerance to 1/8 in. across the entire width and length of the unit.

CLEARANCES

All units require certain clearances for proper operation and service. See Table 5 for the clearances required for construction, servicing, and proper unit operation.

RIGGING AND HANDLING**⚠ CAUTION**

All panels must be secured in place when the unit is lifted. The outdoor coils should be protected from rigging cable damage with plywood or other suitable material.

⚠ CAUTION

If a unit is to be installed on a roof curb other than a Ducted Systems roof curb, gasket or sealant must be applied to all surfaces that come in contact with the unit underside.

Exercise care when moving the unit. Do not remove any packaging until the unit is near the place of installation. Rig the unit by attaching chain or cable slings to the lifting holes provided in the base rails.

Note: Use spreader bars whose length exceeds the largest dimension across the unit across the top of the unit.

⚠ CAUTION

Before lifting, make sure the unit weight is distributed equally on the rigging cables so it will lift evenly.

Units can be moved or lifted with a forklift. Slotted openings in the base rails are provided for this purpose.

Table 3: Weights and Dimensions

| Model | Weight (lb) | | Center of Gravity | | 4-Point Load Location (lb) | | | |
|---------|-------------|-----------|-------------------|----|----------------------------|----|----|----|
| | Shipping | Operating | X | Y | A | B | C | D |
| PCE4A24 | 312 | 307 | 30 | 15 | 124 | 54 | 76 | 53 |
| PCE4A30 | 348 | 343 | 30 | 15 | 125 | 72 | 73 | 73 |
| PCE4A36 | 355 | 350 | 30 | 15 | 130 | 72 | 75 | 73 |
| PCE4A42 | 374 | 369 | 30 | 15 | 134 | 79 | 77 | 79 |
| PCE4B48 | 436 | 431 | 30 | 19 | 165 | 88 | 94 | 84 |
| PCE4B60 | 455 | 450 | 29 | 18 | 177 | 94 | 97 | 82 |

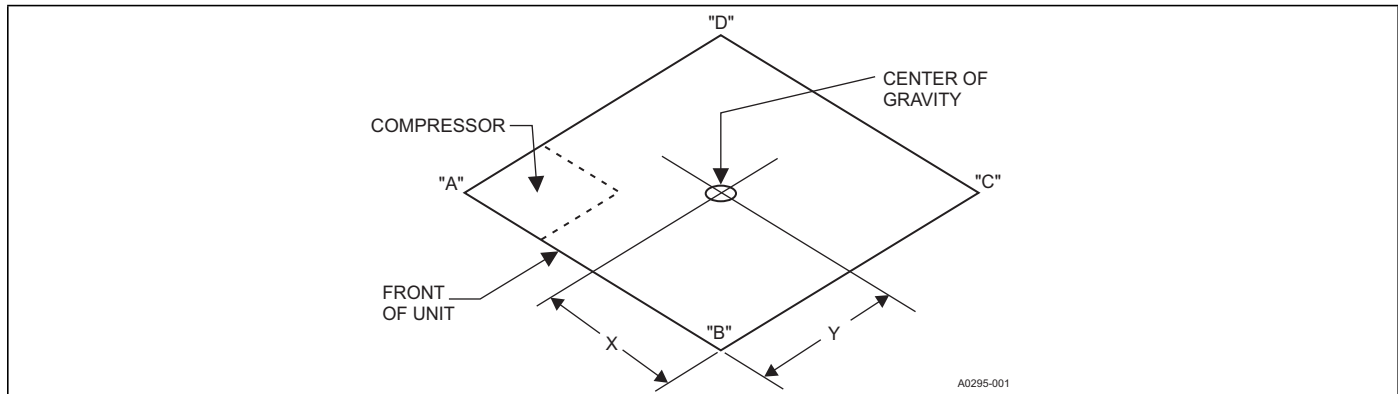

Figure 2: Unit 4-Point Load Weight

Table 4: Unit Dimensions

| Model | Dimensions (in.) | | |
|---------|------------------|--------|----|
| | A | B | C |
| PCE4A24 | 51 1/4 | 35 3/4 | 44 |
| PCE4A30 | 51 1/4 | 35 3/4 | 45 |
| PCE4A36 | 51 1/4 | 35 3/4 | 47 |
| PCE4A42 | 51 1/4 | 35 3/4 | 47 |
| PCE4B48 | 51 1/4 | 45 3/4 | 47 |
| PCE4B60 | 51 1/4 | 45 3/4 | 50 |

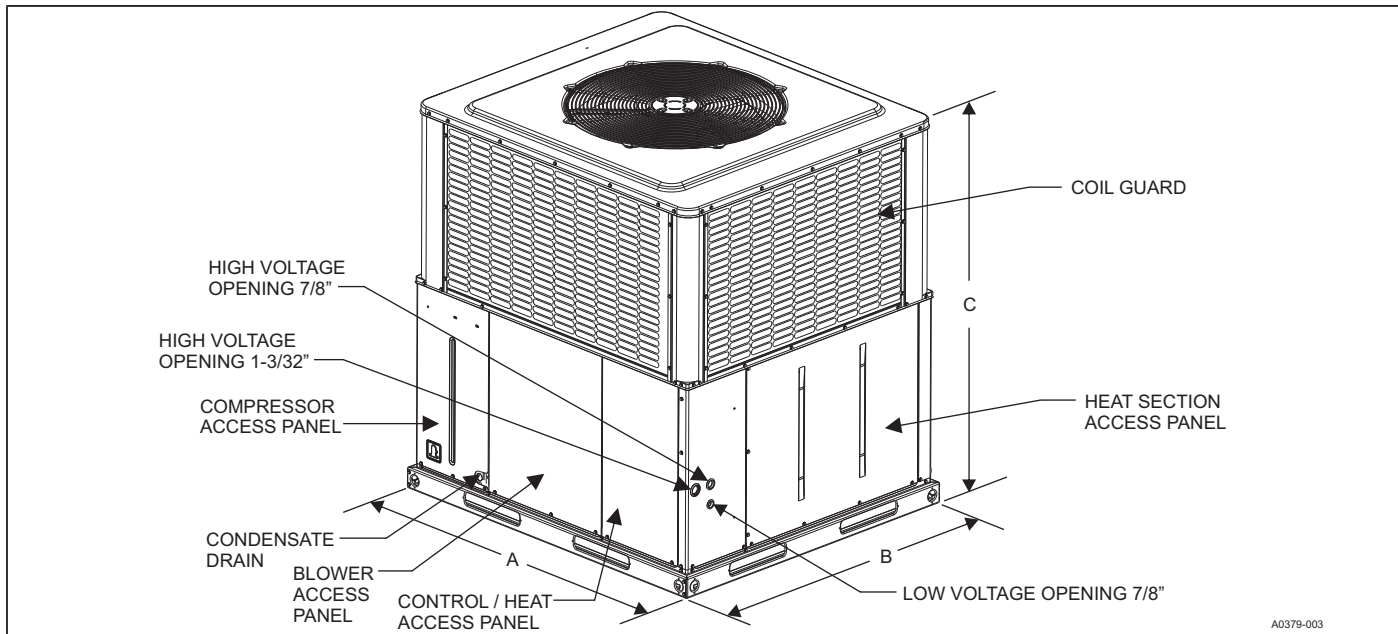

Figure 3: Unit Dimensions

Table 5: Unit Clearances

| Direction | Distance (in.) | Direction | Distance (in.) |
|---------------------|----------------|-----------------------|----------------|
| Top ¹ | 36 | Right Side | 36 |
| Side Opposite Ducts | 36 | Left Side | 24 |
| Duct Panel | 0 | Bottom ^{2,3} | 1 |

- Provide a minimum clearance of 1 in. on all sides of the supply air duct for the first 3 ft of the duct for 20 kW and 25 kW heaters (0 in. thereafter). For all other heaters, make sure that there is 0-in. clearance on all sides for the entire length of the supply air duct.
 - Install units outdoors. Make sure that overhanging structures or shrubs do not obstruct the outdoor air discharge outlet.
 - You can install units on combustible materials made from wood or class A, B, or C roof covering materials if factory base rails are left in place as shipped.
- Note:** For units installed on a roof curb, you can reduce the minimum clearance between combustible roof curb material and the supply air duct from 1 in. to 1/2 in.

DUCTWORK

NOTICE

All units are shipped in the horizontal supply/return configuration. It is important to reduce the possibility of any air leakage through the bottom duct covers (resulting from cut, torn, or rolled gasket) due to improper handling or shipping processes. To ensure a good tight seal, it is recommended that silicone caulk and/or foil tape be applied along the cover edges.

These units are adaptable to downflow use. To convert to downflow:

- Remove the duct covers found in the bottom return and supply air duct openings. There are four screws securing each duct cover. Save these screws to use in Step 2.
- Install the duct covers removed in Step 1 to the rear supply and return air duct openings. Secure with the four screws used in Step 1.
- Seal the duct covers with silicone caulk.

Design and size duct work according to the methods of the Air Conditioning Contractors of America (ACCA), as outlined in their Manual D.

Use a closed return duct system. This does not preclude use of economizers or ventilation air intake. It is best practice to use flexible duct connectors in the supply and return duct work to minimize the transmission of vibration and noise.

CAUTION

When fastening duct work to the side duct flanges on the unit, insert the screws through the duct flanges only. DO NOT insert the screws through the casing. Outdoor duct work must be insulated and water-proofed.

NOTICE

Be sure to note supply and return openings.

See Figure 4 and Figure 5 for information concerning rear and bottom supply and return air duct openings.

FILTERS

Correct filter size is very important. Always consider filter size, type, and pressure drop during duct system design.

Single-phase units are shipped without a filter or filter racks. It is the responsibility of the installer to secure a filter in the return air ductwork or install a filter/frame kit.

A filter rack and high velocity filters are standard on three-phase units.

Always use filters and keep filters clean. When filters become dirt laden, insufficient air is delivered by the blower, decreasing your unit's efficiency and increasing operating costs and wear-and-tear on the unit and controls.

Check filters monthly. This is especially important because the unit can be used for both heating and cooling.

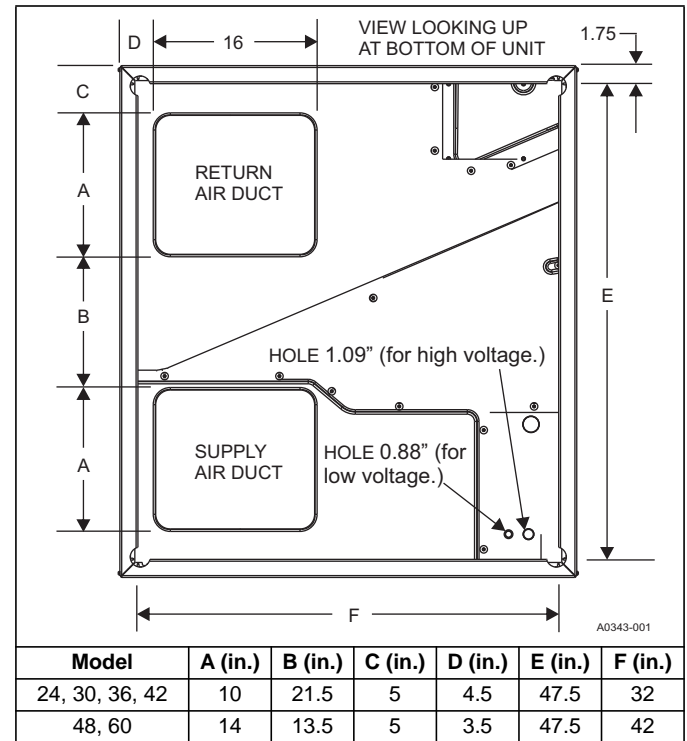

Figure 4: Bottom Duct Dimensions (in.)

NOTE: See Figure titled "Unit Dimensions" for side hole sizes of electrical lines.

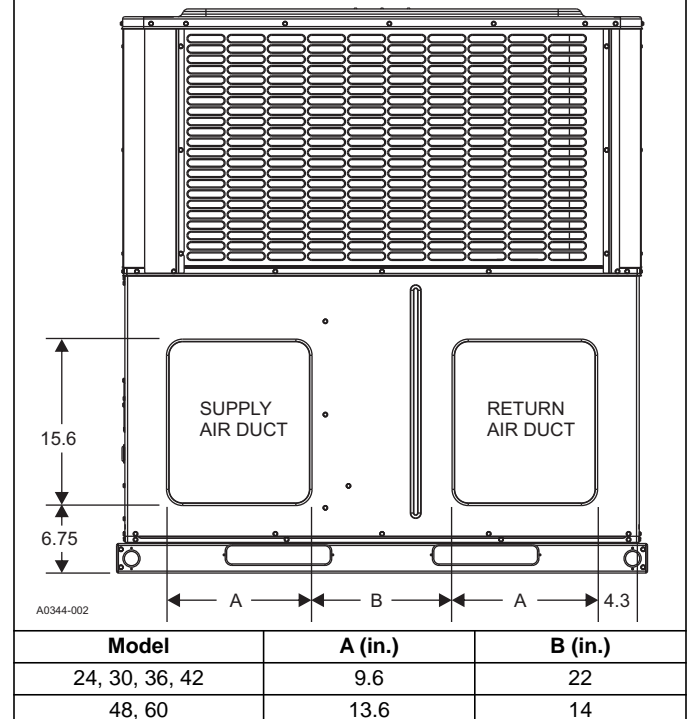

Figure 5: Rear Duct Dimensions (in.)

CONDENSATE DRAIN

Install a condensate trap in the condensate drain. The plumbing must conform to local codes.

⚠ CAUTION

Hand tighten only.

SERVICE ACCESS

Access to all serviceable components is provided at the following locations:

- Coil guards
- Unit top panel
- Corner posts
- Blower access panel
- Control access panel
- Indoor coil access panel
- Compressor access panel

See Figure 3 for the location of these access locations and see Table 5 for minimum clearances.

⚠ CAUTION

This system uses R-410A refrigerant, which operates at higher pressures than R-22. No other refrigerant may be used in this system. Gauge sets, hoses, refrigerant containers, and recovery systems must be designed to handle R-410A. If you are unsure, consult the equipment manufacturer. Failure to use R-410A compatible servicing equipment may result in property damage or injury.

⚠ WARNING

Wear safety glasses and gloves when handling refrigerants. Failure to follow this warning can cause serious personal injury.

See Figure 12 for the R-410A Quick Reference Guide.

THERMOSTAT

Locate the room thermostat on an inside wall approximately 60 in. above the floor where it is not subject to drafts, sun exposure, or heat from electrical fixtures or appliances. Use sealant behind the thermostat to prevent air infiltration. Follow the manufacturer instructions enclosed with the thermostat for the general installation procedure. Use color-coded insulated wires (minimum No. 18 AWG) to connect the thermostat to the unit. See Figure 6. Do not use power stealing thermostats.

POWER AND CONTROL WIRING

Field wiring to the unit must conform to provisions of the current NEC ANSI/NFPA No. 70 or CEC and/or local ordinances. The unit must be electrically grounded in accordance with local codes or, in their absence, with the NEC/CEC. Voltage tolerances that must be maintained at the compressor terminals during starting and running conditions are indicated on the unit Rating Plate and Table 1.

Note: Provide the wiring entering the cabinet with mechanical strain relief.

A fused disconnect switch must be field provided for the unit. If any of the wire supplied with the unit must be replaced, replacement wire must be of the type shown on the wiring diagram.

Electrical service must be sized properly to carry the load. Each unit must be wired with a separate branch circuit fed directly from the main distribution panel and properly fused.

See Figures 6 to 8 for typical field wiring and refer to the appropriate unit wiring diagram for control circuit and power wiring information.

The unit comes wired for 230-V power. If the supply power is 208 V, move wires connected to the control transformer 230-V tap to the 208-V tap.

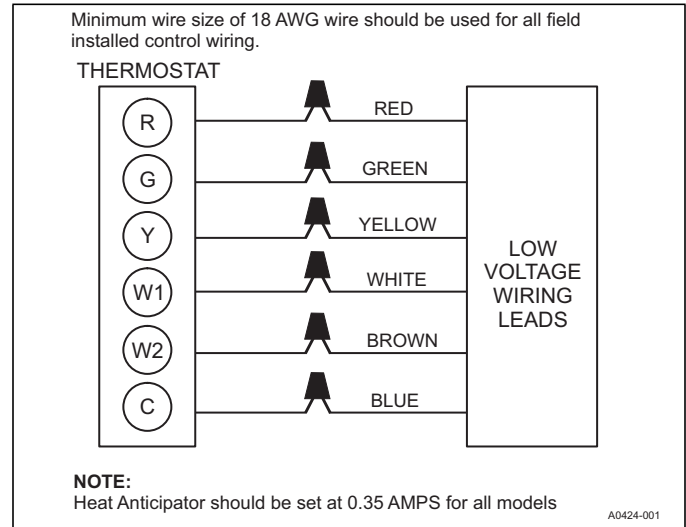

Figure 6: Typical Field Control Wiring Diagram for Air Conditioner Models

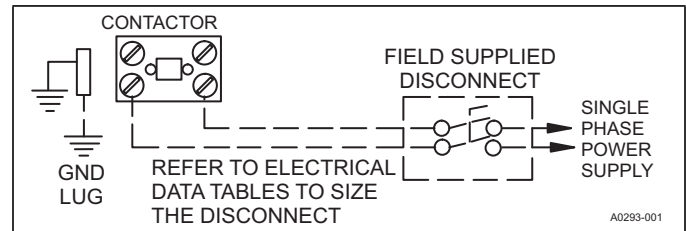

Figure 7: Typical Field Power Wiring Diagram

NOTICE

In some applications, the service disconnects on the electric heat kits must be rotated 180° so the up position of the disconnect is the ON position. This service disconnect orientation change is required by UL1995, Article 26.19 (in reference to all circuit breakers).

Table 6: Electrical Data for 208/230-1-60 Single Source Power

| Model | Compressor | | | OD Fan Motor | Blower Motor | Electric Heat Option | | | | | | MCA ¹ (A) | | Max Fuse ² or Breaker ³ Size | |
|---------|------------|-------|------|--------------|--------------|-------------------------|-------------|------|--------|------------|------|----------------------|-------|--|-----|
| | RLA | LRA | MCC | FLA | FLA | Heater Kit ⁴ | Heater (kW) | | Stages | Heater (A) | | 208 | 230 | 208 | 230 |
| | | | | | | | 208 | 230 | | 208 | 230 | | | | |
| PCE4A24 | 10.8 | 55.0 | 16.8 | 0.8 | 3.8 | none | -- | -- | -- | -- | -- | 18.1 | 18.1 | 25 | 25 |
| | | | | | | 6HK16500506 | 3.6 | 4.4 | 1 | 17.3 | 19.2 | 26.4 | 28.7 | 30 | 30 |
| | | | | | | 6HK16500806 | 5.8 | 7.1 | 1 | 27.7 | 30.7 | 39.4 | 43.1 | 40 | 45 |
| | | | | | | 6HK16501006 | 7.2 | 8.8 | 1 | 34.7 | 38.3 | 48.1 | 52.7 | 50 | 60 |
| PCE4A30 | 12.3 | 63.0 | 19.2 | 0.8 | 3.8 | none | -- | -- | -- | -- | -- | 20.0 | 20.0 | 30 | 30 |
| | | | | | | 6HK16500506 | 3.6 | 4.4 | 1 | 17.3 | 19.2 | 26.4 | 28.7 | 30 | 30 |
| | | | | | | 6HK16500806 | 5.8 | 7.1 | 1 | 27.7 | 30.7 | 39.4 | 43.1 | 40 | 45 |
| | | | | | | 6HK16501006 | 7.2 | 8.8 | 1 | 34.7 | 38.3 | 48.1 | 52.7 | 50 | 60 |
| PCE4A36 | 14.7 | 75.0 | 22.9 | 1.7 | 3.8 | none | -- | -- | -- | -- | -- | 23.9 | 23.9 | 35 | 35 |
| | | | | | | 6HK16500506 | 3.6 | 4.4 | 1 | 17.3 | 19.2 | 26.4 | 28.7 | 35 | 35 |
| | | | | | | 6HK16500806 | 5.8 | 7.1 | 1 | 27.7 | 30.7 | 39.4 | 43.1 | 40 | 45 |
| | | | | | | 6HK16501006 | 7.2 | 8.8 | 1 | 34.7 | 38.3 | 48.1 | 52.7 | 50 | 60 |
| PCE4A42 | 15.9 | 112.3 | 24.8 | 1.7 | 5.4 | none | -- | -- | -- | -- | -- | 27.0 | 27.0 | 40 | 40 |
| | | | | | | 6HK16500506 | 3.6 | 4.4 | 1 | 17.3 | 19.2 | 28.4 | 30.7 | 40 | 40 |
| | | | | | | 6HK16500806 | 5.8 | 7.1 | 1 | 27.7 | 30.7 | 41.4 | 45.1 | 45 | 50 |
| | | | | | | 6HK16501006 | 7.2 | 8.8 | 1 | 34.7 | 38.3 | 50.1 | 54.7 | 60 | 60 |
| PCE4B48 | 18.3 | 108.0 | 28.5 | 1.7 | 5.4 | none | -- | -- | -- | -- | -- | 30.0 | 30.0 | 45 | 45 |
| | | | | | | 6HK16500506 | 3.6 | 4.4 | 1 | 17.3 | 19.2 | 30.0 | 30.7 | 45 | 45 |
| | | | | | | 6HK16500806 | 5.8 | 7.1 | 1 | 27.7 | 30.7 | 41.4 | 45.1 | 45 | 50 |
| | | | | | | 6HK16501006 | 7.2 | 8.8 | 1 | 34.7 | 38.3 | 50.1 | 54.7 | 60 | 60 |
| PCE4B60 | 22.2 | 127.9 | 34.7 | 1.7 | 7.0 | none | -- | -- | -- | -- | -- | 36.5 | 36.5 | 50 | 50 |
| | | | | | | 6HK16500506 | 3.6 | 4.4 | 1 | 17.3 | 19.2 | 36.5 | 36.5 | 50 | 50 |
| | | | | | | 6HK16500806 | 5.8 | 7.1 | 1 | 27.7 | 30.7 | 43.4 | 47.1 | 50 | 50 |
| | | | | | | 6HK16501006 | 7.2 | 8.8 | 1 | 34.7 | 38.3 | 52.1 | 56.7 | 60 | 60 |
| PCE4B60 | 22.2 | 127.9 | 34.7 | 1.7 | 7.0 | none | -- | -- | -- | -- | -- | 36.5 | 36.5 | 50 | 50 |
| | | | | | | 6HK16501506 | 10.8 | 13.2 | 2 | 52.0 | 57.5 | 73.8 | 80.6 | 80 | 90 |
| | | | | | | 6HK16502006 | 14.4 | 17.6 | 2 | 69.3 | 76.7 | 95.4 | 104.6 | 100 | 110 |

1. Minimum circuit ampacity

2. Maximum overcurrent protection per standard UL 1995

3. Fuse or HACR circuit breaker is field installed

4. Single-point connection kit is required

Table 7: Electrical Data for 208-1-60 Multi Source Power - PCE4

| Model | Compressor | | | OD Fan Motor | Blower Motor | Electric Heat Option | | | Multi Source | | | | | | | | |
|--|------------|-------|------|--------------|--------------|----------------------|------------------------------|--------|--------------|----------------------|------------------|----------------------|------------------|----------------------|------------------|----------------------|------------------|
| | RLA | LRA | MCC | FLA | FLA | Heater Kit | Heater (kW) | Stages | Heater (A) | 208 | 208 | 208 | 208 | 208 | 208 | 208 | 208 |
| | | | | | | | 208 | | 208 | | | | | | | | |
| Multi Source: Compressor Circuit and Heat Circuits | | | | | | Multi Source: | Circuit 1 Compressor Circuit | | | MCA ¹ (A) | MOP ² | MCA ¹ (A) | MOP ² | MCA ¹ (A) | MOP ² | MCA ¹ (A) | MOP ² |
| | | | | | | | Circuit 2 Heat | | | | | | | | | | |
| | | | | | | | Circuit 3 Heat | | | Circuit 1 | | Circuit 2 | | Circuit 3 | | Circuit 4 | |
| | | | | | | | Circuit 4 Heat | | | Circuit 1 | | Circuit 2 | | Circuit 3 | | Circuit 4 | |
| A24 | 10.8 | 55.0 | 16.8 | 0.8 | 3.8 | none | -- | -- | -- | 18.1 | 25 | -- | -- | -- | -- | -- | -- |
| | | | | | | 6HK(0,1)6500506 | 3.6 | 1 | 17.3 | 18.1 | 25 | 21.7 | 25 | -- | -- | -- | -- |
| | | | | | | 6HK(0,1)6500806 | 5.8 | 1 | 27.7 | 18.1 | 25 | 34.7 | 35 | -- | -- | -- | -- |
| | | | | | | 6HK(0,1)6501006 | 7.2 | 1 | 34.7 | 18.1 | 25 | 43.3 | 45 | -- | -- | -- | -- |
| A30 | 12.3 | 63.0 | 19.2 | 0.8 | 3.8 | none | -- | -- | -- | 20.0 | 30 | -- | -- | -- | -- | -- | -- |
| | | | | | | 6HK(0,1)6500506 | 3.6 | 1 | 17.3 | 20.0 | 30 | 21.7 | 25 | -- | -- | -- | -- |
| | | | | | | 6HK(0,1)6500806 | 5.8 | 1 | 27.7 | 20.0 | 30 | 34.7 | 35 | -- | -- | -- | -- |
| | | | | | | 6HK(0,1)6501006 | 7.2 | 1 | 34.7 | 20.0 | 30 | 43.3 | 45 | -- | -- | -- | -- |
| | | | | | | 6HK16501506 | 10.8 | 2 | 52.0 | 20.0 | 30 | 21.7 | 25 | 43.3 | 45 | -- | -- |
| | | | | | | 6HK26501506 | 10.8 | 2 | 52.0 | 20.0 | 30 | 65.0 | 70 | -- | -- | -- | -- |
| A36 | 14.7 | 75.0 | 22.9 | 1.7 | 3.8 | none | -- | -- | -- | 23.9 | 35 | -- | -- | -- | -- | -- | -- |
| | | | | | | 6HK(0,1)6500506 | 3.6 | 1 | 17.3 | 23.9 | 35 | 21.7 | 25 | -- | -- | -- | -- |
| | | | | | | 6HK(0,1)6500806 | 5.8 | 1 | 27.7 | 23.9 | 35 | 34.7 | 35 | -- | -- | -- | -- |
| | | | | | | 6HK(0,1)6501006 | 7.2 | 1 | 34.7 | 23.9 | 35 | 43.3 | 45 | -- | -- | -- | -- |
| | | | | | | 6HK16501506 | 10.8 | 2 | 52.0 | 23.9 | 35 | 21.7 | 25 | 43.3 | 45 | -- | -- |
| | | | | | | 6HK26501506 | 10.8 | 2 | 52.0 | 23.9 | 35 | 65.0 | 70 | -- | -- | -- | -- |
| A42 | 15.9 | 112.3 | 24.8 | 1.7 | 5.4 | none | -- | -- | -- | 27.0 | 40 | -- | -- | -- | -- | -- | -- |
| | | | | | | 6HK(0,1)6500506 | 3.6 | 1 | 17.3 | 27.0 | 40 | 21.7 | 25 | -- | -- | -- | -- |
| | | | | | | 6HK(0,1)6500806 | 5.8 | 1 | 27.7 | 27.0 | 40 | 34.7 | 35 | -- | -- | -- | -- |
| | | | | | | 6HK(0,1)6501006 | 7.2 | 1 | 34.7 | 27.0 | 40 | 43.3 | 45 | -- | -- | -- | -- |
| | | | | | | 6HK16501506 | 10.8 | 2 | 52.0 | 27.0 | 40 | 21.7 | 25 | 43.3 | 45 | -- | -- |
| | | | | | | 6HK16502006 | 14.4 | 2 | 69.3 | 27.0 | 40 | 43.3 | 45 | 43.3 | 45 | -- | -- |
| | | | | | | 6HK26501506 | 10.8 | 2 | 52.0 | 27.0 | 40 | 65.0 | 70 | -- | -- | -- | -- |
| | | | | | | 6HK26502006 | 14.4 | 2 | 69.3 | 27.0 | 40 | 86.7 | 90 | -- | -- | -- | -- |
| B48 | 18.3 | 108.0 | 28.5 | 1.7 | 5.4 | none | -- | -- | -- | 30.0 | 45 | -- | -- | -- | -- | -- | -- |
| | | | | | | 6HK(0,1)6500506 | 3.6 | 1 | 17.3 | 30.0 | 45 | 21.7 | 25 | -- | -- | -- | -- |
| | | | | | | 6HK(0,1)6500806 | 5.8 | 1 | 27.7 | 30.0 | 45 | 34.7 | 35 | -- | -- | -- | -- |
| | | | | | | 6HK(0,1)6501006 | 7.2 | 1 | 34.7 | 30.0 | 45 | 43.3 | 45 | -- | -- | -- | -- |
| | | | | | | 6HK16501506 | 10.8 | 2 | 52.0 | 30.0 | 45 | 21.7 | 25 | 43.3 | 45 | -- | -- |
| | | | | | | 6HK16502006 | 14.4 | 2 | 69.3 | 30.0 | 45 | 43.3 | 45 | 43.3 | 45 | -- | -- |
| | | | | | | 6HK26501506 | 10.8 | 2 | 52.0 | 30.0 | 45 | 65.0 | 70 | -- | -- | -- | -- |
| | | | | | | 6HK26502006 | 14.4 | 2 | 69.3 | 30.0 | 45 | 86.7 | 90 | -- | -- | -- | -- |
| B60 | 22.2 | 127.9 | 34.7 | 1.7 | 7.0 | none | -- | -- | -- | 36.5 | 50 | -- | -- | -- | -- | -- | -- |
| | | | | | | 6HK(0,1)6500506 | 3.6 | 1 | 17.3 | 36.5 | 50 | 21.7 | 25 | -- | -- | -- | -- |
| | | | | | | 6HK(0,1)6500806 | 5.8 | 1 | 27.7 | 36.5 | 50 | 34.7 | 35 | -- | -- | -- | -- |
| | | | | | | 6HK(0,1)6501006 | 7.2 | 1 | 34.7 | 36.5 | 50 | 43.3 | 45 | -- | -- | -- | -- |
| | | | | | | 6HK16501506 | 10.8 | 2 | 52.0 | 36.5 | 50 | 21.7 | 25 | 43.3 | 45 | -- | -- |
| | | | | | | 6HK16502006 | 14.4 | 2 | 69.3 | 36.5 | 50 | 43.3 | 45 | 43.3 | 45 | -- | -- |
| | | | | | | 6HK16502506 | 18.0 | 2 | 86.7 | 36.5 | 50 | 43.3 | 45 | 43.3 | 45 | 21.7 | 25 |
| | | | | | | 6HK26501506 | 10.8 | 2 | 52.0 | 36.5 | 50 | 65.0 | 70 | -- | -- | -- | -- |
| | | | | | | 6HK26502006 | 14.4 | 2 | 69.3 | 36.5 | 50 | 86.7 | 90 | -- | -- | -- | -- |
| 6HK26502506 | 18.0 | 2 | 86.7 | 36.5 | 50 | 108.3 | 110 | -- | -- | -- | -- | | | | | | |

1. MCA = Minimum circuit ampacity

2. MOP = Maximum overcurrent protection device. Must be HACR type circuit breaker or time delay fuse

Table 8: Electrical Data for 230-1-60 Multi Source Power - PCE4

| Model | Compressor | | | OD Fan Motor | Blower Motor | Electric Heat Option | | | | Multi Source | | | | | | | |
|--|------------|-------|----------------------|------------------|----------------------|----------------------|------------------------------|-----------|----------------------|--------------|-----------|-----------|-----------|-----------|-----------|------|------|
| | | | | | | Heater Kit | Heater kW | Stages | Heater (A) | 230 | 230 | 230 | 230 | 230 | 230 | 230 | 230 |
| | 230 | 230 | MCA ¹ (A) | MOP ² | MCA ¹ (A) | | MOP ² | | MCA ¹ (A) | | | | | | | | |
| Multi Source: Compressor Circuit and Heat Circuits | | | | | | Multi Source: | Circuit 1 Compressor Circuit | Circuit 1 | Circuit 2 | Circuit 3 | Circuit 4 | Circuit 1 | Circuit 2 | Circuit 3 | Circuit 4 | | |
| | | | | | | | Circuit 2 Heat | | | | | | | | | | |
| | | | | | | | Circuit 3 Heat | | | | | | | | | | |
| | | | | | | | Circuit 4 Heat | | | | | | | | | | |
| A24 | 10.8 | 55.0 | 16.8 | 0.8 | 3.8 | none | -- | -- | -- | 18.1 | 25 | -- | -- | -- | -- | -- | -- |
| | | | | | | 6HK(0,1)6500506 | 4.4 | 1 | 19.2 | 18.1 | 25 | 24.0 | 25.0 | -- | -- | -- | -- |
| | | | | | | 6HK(0,1)6500806 | 7.1 | 1 | 30.7 | 18.1 | 25 | 38.3 | 40.0 | -- | -- | -- | -- |
| | | | | | | 6HK(0,1)6501006 | 8.8 | 1 | 38.3 | 18.1 | 25 | 47.9 | 50.0 | -- | -- | -- | -- |
| A30 | 12.3 | 63.0 | 19.2 | 0.8 | 3.8 | none | -- | -- | -- | 20.0 | 30 | -- | -- | -- | -- | -- | -- |
| | | | | | | 6HK(0,1)6500506 | 4.4 | 1 | 19.2 | 20.0 | 30 | 24.0 | 25.0 | -- | -- | -- | -- |
| | | | | | | 6HK(0,1)6500806 | 7.1 | 1 | 30.7 | 20.0 | 30 | 38.3 | 40.0 | -- | -- | -- | -- |
| | | | | | | 6HK(0,1)6501006 | 8.8 | 1 | 38.3 | 20.0 | 30 | 47.9 | 50.0 | -- | -- | -- | -- |
| | | | | | | 6HK16501506 | 13.2 | 2 | 57.5 | 20.0 | 30 | 24.0 | 25.0 | 47.9 | 50.0 | -- | -- |
| | | | | | | 6HK26501506 | 13.2 | 2 | 57.5 | 20.0 | 30 | 71.9 | 80.0 | -- | -- | -- | -- |
| A36 | 14.7 | 75.0 | 22.9 | 1.7 | 3.8 | none | -- | -- | -- | 23.9 | 35 | -- | -- | -- | -- | -- | -- |
| | | | | | | 6HK(0,1)6500506 | 4.4 | 1 | 19.2 | 23.9 | 35 | 24.0 | 25.0 | -- | -- | -- | -- |
| | | | | | | 6HK(0,1)6500806 | 7.1 | 1 | 30.7 | 23.9 | 35 | 38.3 | 40.0 | -- | -- | -- | -- |
| | | | | | | 6HK(0,1)6501006 | 8.8 | 1 | 38.3 | 23.9 | 35 | 47.9 | 50.0 | -- | -- | -- | -- |
| | | | | | | 6HK16501506 | 13.2 | 2 | 57.5 | 23.9 | 35 | 24.0 | 25.0 | 47.9 | 50.0 | -- | -- |
| | | | | | | 6HK26501506 | 13.2 | 2 | 57.5 | 23.9 | 35 | 71.9 | 80.0 | -- | -- | -- | -- |
| A42 | 15.9 | 112.3 | 24.8 | 1.7 | 5.4 | none | -- | -- | -- | 27.0 | 40 | -- | -- | -- | -- | -- | -- |
| | | | | | | 6HK(0,1)6500506 | 4.4 | 1 | 19.2 | 27.0 | 40 | 24.0 | 25.0 | -- | -- | -- | -- |
| | | | | | | 6HK(0,1)6500806 | 7.1 | 1 | 30.7 | 27.0 | 40 | 38.3 | 40.0 | -- | -- | -- | -- |
| | | | | | | 6HK(0,1)6501006 | 8.8 | 1 | 38.3 | 27.0 | 40 | 47.9 | 50.0 | -- | -- | -- | -- |
| | | | | | | 6HK16501506 | 13.2 | 2 | 57.5 | 27.0 | 40 | 24.0 | 25.0 | 47.9 | 50.0 | -- | -- |
| | | | | | | 6HK16502006 | 17.6 | 2 | 76.7 | 27.0 | 40 | 47.9 | 50.0 | 47.9 | 50.0 | -- | -- |
| | | | | | | 6HK26501506 | 13.2 | 2 | 57.5 | 27.0 | 40 | 71.9 | 80.0 | -- | -- | -- | -- |
| | | | | | | 6HK26502006 | 17.6 | 2 | 76.7 | 27.0 | 40 | 95.8 | 100.0 | -- | -- | -- | -- |
| B48 | 18.3 | 108.0 | 28.5 | 1.7 | 5.4 | none | -- | -- | -- | 30.0 | 45 | -- | -- | -- | -- | -- | -- |
| | | | | | | 6HK(0,1)6500506 | 4.4 | 1 | 19.2 | 30.0 | 45 | 24.0 | 25.0 | -- | -- | -- | -- |
| | | | | | | 6HK(0,1)6500806 | 7.1 | 1 | 30.7 | 30.0 | 45 | 38.3 | 40.0 | -- | -- | -- | -- |
| | | | | | | 6HK(0,1)6501006 | 8.8 | 1 | 38.3 | 30.0 | 45 | 47.9 | 50.0 | -- | -- | -- | -- |
| | | | | | | 6HK16501506 | 13.2 | 2 | 57.5 | 30.0 | 45 | 24.0 | 25.0 | 47.9 | 50.0 | -- | -- |
| | | | | | | 6HK16502006 | 17.6 | 2 | 76.7 | 30.0 | 45 | 47.9 | 50.0 | 47.9 | 50.0 | -- | -- |
| | | | | | | 6HK26501506 | 13.2 | 2 | 57.5 | 30.0 | 45 | 71.9 | 80.0 | -- | -- | -- | -- |
| | | | | | | 6HK26502006 | 17.6 | 2 | 76.7 | 30.0 | 45 | 95.8 | 100.0 | -- | -- | -- | -- |
| B60 | 22.2 | 127.9 | 34.7 | 1.7 | 7.0 | none | -- | -- | -- | 36.5 | 50 | -- | -- | -- | -- | -- | -- |
| | | | | | | 6HK(0,1)6500506 | 4.4 | 1 | 19.2 | 36.5 | 50 | 24.0 | 25.0 | -- | -- | -- | -- |
| | | | | | | 6HK(0,1)6500806 | 7.1 | 1 | 30.7 | 36.5 | 50 | 38.3 | 40.0 | -- | -- | -- | -- |
| | | | | | | 6HK(0,1)6501006 | 8.8 | 1 | 38.3 | 36.5 | 50 | 47.9 | 50.0 | -- | -- | -- | -- |
| | | | | | | 6HK16501506 | 13.2 | 2 | 57.5 | 36.5 | 50 | 24.0 | 25.0 | 47.9 | 50.0 | -- | -- |
| | | | | | | 6HK16502006 | 17.6 | 2 | 76.7 | 36.5 | 50 | 47.9 | 50.0 | 47.9 | 50.0 | -- | -- |
| | | | | | | 6HK16502506 | 22.0 | 2 | 95.8 | 36.5 | 50 | 47.9 | 50.0 | 47.9 | 50.0 | 24.0 | 25.0 |
| | | | | | | 6HK26501506 | 13.2 | 2 | 57.5 | 36.5 | 50 | 71.9 | 80.0 | -- | -- | -- | -- |
| | | | | | | 6HK26502006 | 17.6 | 2 | 76.7 | 36.5 | 50 | 95.8 | 100.0 | -- | -- | -- | -- |
| 6HK26502506 | 22.0 | 2 | 95.8 | 36.5 | 50 | 119.8 | 125.0 | -- | -- | -- | -- | | | | | | |

1. MCA = minimum circuit ampacity

2. MOP = Maximum overcurrent protection device. Must be HACR type circuit breaker or time delay fuse

Table 9: Electric Heat Performance Data: 208/230-1-60

| Heater Models ^{1,2} | Nominal kW at 240 V | Total Heat | | | | kW Staging | | | |
|------------------------------|---------------------|------------|-------|-------|-------|------------|-------|---------|-------|
| | | kW | | MBH | | W1 Only | | W1 + W2 | |
| | | 208 V | 230 V | 208 V | 230 V | 208 V | 230 V | 208 V | 230 V |
| 6HK(0,1)6500506 | 4.8 | 3.6 | 4.4 | 12.3 | 15 | 3.6 | 4.4 | 3.6 | 4.4 |
| 6HK(0,1)6500806 | 7.7 | 5.8 | 7.1 | 19.7 | 24.1 | 5.8 | 7.1 | 5.8 | 7.1 |
| 6HK(0,1)6501006 | 9.6 | 7.2 | 8.8 | 24.6 | 30.1 | 7.2 | 8.8 | 7.2 | 8.8 |
| 6HK(1,2)6501506 | 14.4 | 10.8 | 13.2 | 36.9 | 45.1 | 3.6 | 4.4 | 10.8 | 13.2 |
| 6HK(1,2)6502006 | 19.2 | 14.4 | 17.6 | 49.2 | 60.2 | 7.2 | 8.8 | 14.4 | 17.6 |
| 6HK(1,2)6502506 | 24.0 | 18.0 | 22.0 | 61.5 | 75.2 | 7.2 | 8.8 | 18 | 22 |

1. (0,1): 0 = no service disconnect or 1 = with service disconnect
2. (1,2): 1 = with service disconnect, no breaker jumper bar or 2 = with service disconnect and breaker jumper bar

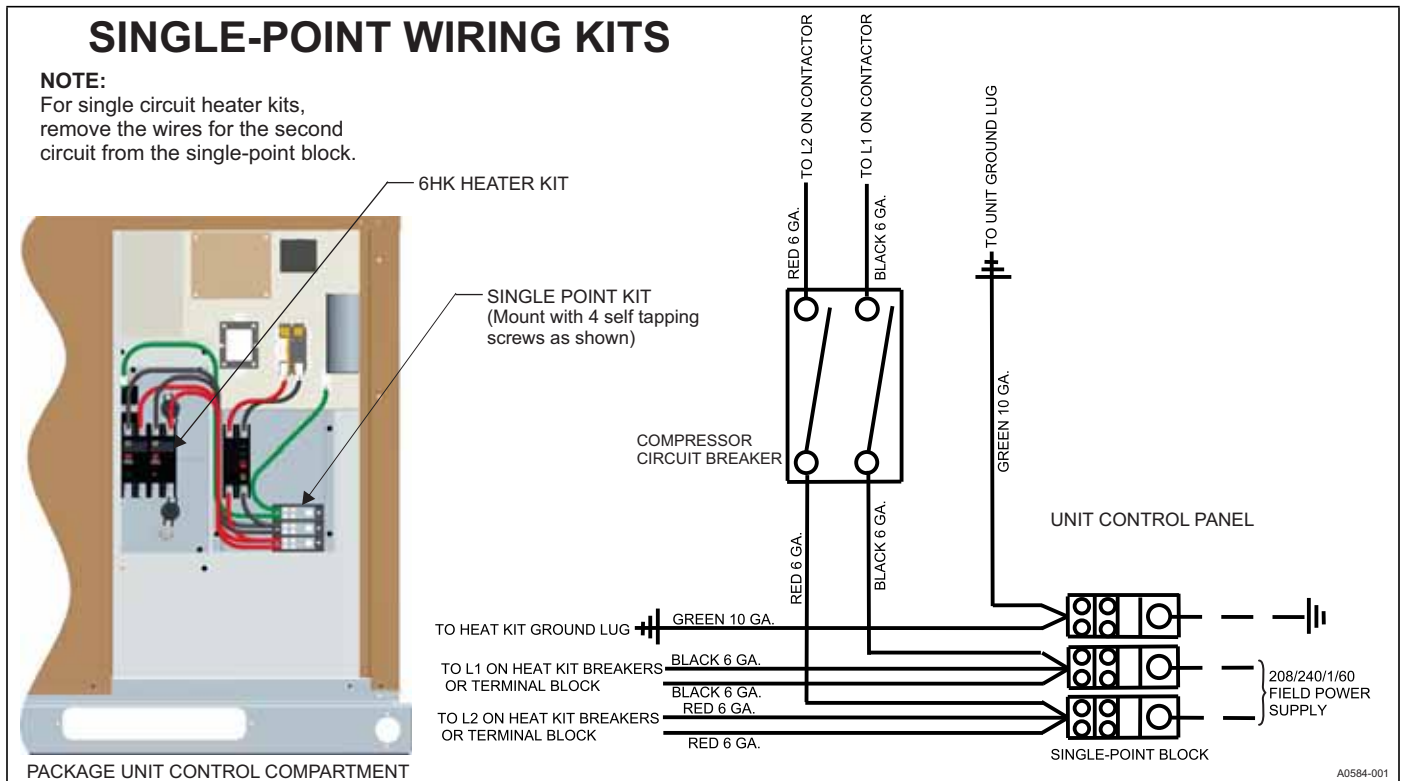

Figure 8: Single-Point Wiring Kits

Table 10: Single-Point Wiring Kits

| Unit Model Number | Single-Point Kit P/N | Breaker Size | Heat Kit |
|-------------------|----------------------|--------------|-------------|
| PCE4A24 | S1-2SPWK006 | 25 A | Up to 10 kW |
| PCE4A30 | S1-2SPWK001 | 30 A | Up to 15 kW |
| PCE4A36 | S1-2SPWK002 | 35 A | Up to 15 kW |
| PCE4A42 | S1-2SPWK007 | 40 A | Up to 20 kW |
| PCE4B48 | S1-2SPWK003 | 45 A | Up to 20 kW |
| PCE4B60 | S1-2SPWK004 | 50 A | Up to 20 kW |

Table 11: Physical Data

| NOMINAL TONNAGE | MODELS | | | | | |
|--|--|-------------|-------------|-------------|-------------|-------------|
| | PCE4A24 | PCE4A30 | PCE4A36 | PCE4A42 | PCE4B48 | PCE4B60 |
| | 2.0 | 2.5 | 3.0 | 3.5 | 4.0 | 5.0 |
| Refrigerant Information | | | | | | |
| Refrigerant Type | R-410A | R-410A | R-410A | R-410A | R-410A | R-410A |
| Refrigerant Charge (lb-oz) | 3-10 | 6-10 | 6-14 | 7-0 | 7-14 | 10-2 |
| Dimensions (in.) | | | | | | |
| Length | 51 1/4 | 51 1/4 | 51 1/4 | 51 1/4 | 51 1/4 | 51 1/4 |
| Width | 35 3/4 | 35 3/4 | 35 3/4 | 35 3/4 | 45 3/4 | 45 3/4 |
| Height | 44 | 45 | 47 | 47 | 47 | 50 |
| Operating Weight (lb) | 307 | 343 | 350 | 369 | 431 | 450 |
| Compressors | | | | | | |
| Type | Scroll | Scroll | Scroll | Scroll | Scroll | Scroll |
| Outdoor Coil Data | | | | | | |
| Face Area (sq. ft) | 12.3 | 13.8 | 15.3 | 15.3 | 17.5 | 21.1 |
| Rows | 1 | 2 | 2 | 2 | 2 | 2 |
| Fins per Inch | 22 | 22 | 22 | 22 | 22 | 22 |
| Tube Diameter (mm) | 7 | 7 | 7 | 7 | 7 | 7 |
| Circuitry Type | Straight | Interlaced | Interlaced | Interlaced | Interlaced | Interlaced |
| Indoor Coil Data | | | | | | |
| Face Area (sq. ft) | 4.6 | 4.6 | 4.6 | 4.6 | 6.2 | 6.2 |
| Rows | 2 | 2 | 3 | 3 | 3 | 4 |
| Fins per Inch | 16 | 16 | 16 | 16 | 16 | 16 |
| Tube Diameter (in.) | 3/8 | 3/8 | 3/8 | 3/8 | 3/8 | 3/8 |
| Circuitry Type | Interlaced | Interlaced | Interlaced | Interlaced | Interlaced | Interlaced |
| Refrigerant Control | TXV | TXV | TXV | TXV | TXV | TXV |
| Outdoor Fan Data | | | | | | |
| Fan Diameter (in.) | 24 | 24 | 24 | 24 | 26 | 26 |
| Type | Prop | Prop | Prop | Prop | Prop | Prop |
| Drive Type | Direct | Direct | Direct | Direct | Direct | Direct |
| Number of Speeds | 1 | 1 | 1 | 1 | 1 | 1 |
| Motor HP each | 1/8 | 1/8 | 1/3 | 1/3 | 1/3 | 1/3 |
| RPM | 790 | 790 | 850 | 850 | 850 | 850 |
| Nominal Total CFM | 2400 | 2400 | 2400 | 2400 | 3200 | 3200 |
| Direct Drive Indoor Blower Data | | | | | | |
| Blower Size (in.) | 11 x 8 | 11 x 8 | 11 x 10 | 11 x 10 | 11 x 10 | 11 x 10 |
| Type | Centrifugal | Centrifugal | Centrifugal | Centrifugal | Centrifugal | Centrifugal |
| Motor HP each | 1/2 | 1/2 | 1/2 | 3/4 | 3/4 | 1 |
| RPM | 1400 Max | 1400 Max | 1400 Max | 1400 Max | 1400 Max | 1400 Max |
| Frame Size | 48 | 48 | 48 | 48 | 48 | 48 |
| Filters | | | | | | |
| Filter Size | A | A | A | A | B | B |
| Quantity - Size | Field-supplied external filters must be sized so as not to exceed 300 fpm air velocity through disposable filters. For internal filter use, a filter rack kit is available. Refer to the instructions supplied with the kit for replacement filter sizes. Filter sizes: A = 20 in. x 20 in., B = 20 in. x 30 in. | | | | | |

COMPRESSORS

⚠ CAUTION

This system uses R-410A refrigerant, which operates at higher pressures than R-22. No other refrigerant may be used in this system.

The compressor used in this product is specifically designed to operate with R-410A refrigerant and cannot be interchanged with a different type of compressor.

The compressor uses polyolester (POE) oil, Mobil 3MA POE. This oil is extremely hygroscopic, meaning it absorbs water readily. POE oil can absorb 15 times as much water as other oils designed for HCFC and CFC refrigerants. If the refrigerant circuit is opened, take all necessary precautions to avoid exposure of the oil to the atmosphere.

⚠ CAUTION

*Do not leave the system open to the atmosphere. Unit damage could occur due to moisture being absorbed by the **POE oil** in the system. This type of oil is highly susceptible to moisture absorption*

POE compressor lubricants are known to cause long-term damage to some synthetic roofing materials.

⚠ CAUTION

Exposure, even if immediately cleaned up, may cause embrittlement (leading to cracking) to occur in one year or more. When performing any service that may risk exposure of compressor oil to the roof, take precautions to protect roofing.

Procedures that risk oil leakage include, but are not limited to the following:

- Replacing the compressor
- Repairing refrigerant leaks
- Replacing refrigerant components, for example, filter drier, pressure switch, metering device, or coil

⚠ CAUTION

Do not loosen compressor mounting bolts.

Units are shipped with compressor mountings, which are factory-adjusted and ready for operation.

SECTION V: AIRFLOW PERFORMANCE

Table 12: Airflow Performance - Side Duct Application

| Model | Motor Speed | External Static Pressure (in. W.C.) | | | | | | | | |
|---------|-----------------|-------------------------------------|------|------|------|------|------|------|------|------|
| | | 0.1 | 0.2 | 0.3 | 0.4 | 0.5 | 0.6 | 0.7 | 0.8 | 1.0 |
| | | SCFM | SCFM | SCFM | SCFM | SCFM | SCFM | SCFM | SCFM | SCFM |
| PCE4A24 | Low (1) | 580 | 550 | 500 | 440 | 390 | 350 | 290 | 240 | 130 |
| | Medium Low (2) | 690 | 660 | 620 | 570 | 520 | 460 | 410 | 360 | 270 |
| | Medium (3) | 800 | 760 | 720 | 680 | 630 | 570 | 530 | 480 | 400 |
| | Medium High (4) | 910 | 870 | 840 | 810 | 770 | 730 | 680 | 620 | 540 |
| | High (5) | 1120 | 1080 | 1060 | 1030 | 1000 | 970 | 930 | 890 | 820 |
| PCE4A30 | Low (1) | 690 | 660 | 620 | 570 | 520 | 460 | 410 | 360 | 270 |
| | Medium Low (2) | 840 | 800 | 770 | 730 | 680 | 630 | 590 | 530 | 450 |
| | Medium (3) | 1040 | 1010 | 980 | 940 | 910 | 880 | 840 | 800 | 700 |
| | Medium High (4) | 1180 | 1160 | 1130 | 1100 | 1070 | 1050 | 1010 | 980 | 910 |
| | High (5) | 1310 | 1280 | 1260 | 1230 | 1200 | 1180 | 1150 | 1110 | 1050 |
| PCE4A36 | Low (1) | 850 | 790 | 710 | 660 | 610 | 560 | 510 | 450 | 400 |
| | Medium Low (2) | 1100 | 1050 | 1010 | 960 | 900 | 840 | 790 | 750 | 660 |
| | Medium (3) | 1270 | 1230 | 1190 | 1150 | 1110 | 1060 | 1000 | 960 | 860 |
| | Medium High (4) | 1370 | 1340 | 1300 | 1260 | 1220 | 1180 | 1130 | 1070 | 980 |
| | High (5) | 1490 | 1450 | 1420 | 1380 | 1340 | 1300 | 1260 | 1210 | 1120 |
| PCE4A42 | Low (1) | 950 | 890 | 830 | 760 | 700 | 650 | 590 | 550 | 390 |
| | Medium Low (2) | 1320 | 1280 | 1240 | 1200 | 1150 | 1100 | 1050 | 990 | 900 |
| | Medium (3) | 1530 | 1490 | 1450 | 1420 | 1370 | 1330 | 1280 | 1230 | 1120 |
| | Medium High (4) | 1640 | 1600 | 1570 | 1530 | 1490 | 1450 | 1410 | 1360 | 1270 |
| | High (5) | 1890 | 1860 | 1830 | 1800 | 1760 | 1730 | 1700 | 1640 | 1510 |
| PCE4B48 | Low (1) | 1140 | 1090 | 1030 | 980 | 920 | 850 | 780 | 730 | 600 |
| | Medium Low (2) | 1350 | 1300 | 1250 | 1200 | 1160 | 1100 | 1050 | 1000 | 870 |
| | Medium (3) | 1690 | 1650 | 1600 | 1570 | 1530 | 1490 | 1440 | 1400 | 1310 |
| | Medium High (4) | 1800 | 1760 | 1720 | 1680 | 1650 | 1610 | 1560 | 1520 | 1440 |
| | High (5) | 2020 | 1980 | 1940 | 1910 | 1870 | 1830 | 1790 | 1760 | 1690 |
| PCE4B60 | Low (1) | 1300 | 1240 | 1200 | 1150 | 1090 | 1050 | 1000 | 940 | 820 |
| | Medium Low (2) | 1520 | 1480 | 1450 | 1400 | 1360 | 1320 | 1280 | 1240 | 1150 |
| | Medium (3) | 1870 | 1840 | 1810 | 1770 | 1730 | 1690 | 1650 | 1620 | 1540 |
| | Medium High (4) | 2000 | 1970 | 1930 | 1890 | 1860 | 1830 | 1780 | 1740 | 1670 |
| | High (5) | 2240 | 2210 | 2180 | 2150 | 2100 | 2070 | 2040 | 2140 | 2050 |

Notes:

Airflow is tested with dry coil conditions, without air filters, at 230 V.

Applications above 0.8 in. W.C. external static pressure are not recommended.

Brushless DC high-efficiency standard ECM blower motor is used for all indoor blower assemblies.

Minimal variations in airflow performance data result from operating at 208 V. The data in the table can be used in those cases.

Heating applications are tested at 0.50 in. W.C. external static pressure. Cooling applications are tested per AHRI Standard 210/240.

The differences between side duct airflows and bottom duct airflows are insignificant.

Table 13: Electric Heat Minimum Supply Air

| Model | Voltage | Minimum Blower Speed for Electric Heat | | | | | |
|---------|--------------|--|-----------------|-----------------|-----------------|------------|------------|
| | | Heater kW | | | | | |
| | | 5 | 8 | 10 | 15 | 20 | 25 |
| PCE4A24 | 208/230-1-60 | Medium (3) | Medium High (4) | Medium High (4) | -- | -- | -- |
| PCE4A30 | 208/230-1-60 | Medium Low (2) | Medium High (4) | Medium High (4) | Medium High (4) | -- | -- |
| PCE4A36 | 208/230-1-60 | Medium Low (2) | Medium Low (2) | Medium High (4) | Medium High (4) | -- | -- |
| PCE4A42 | 208/230-1-60 | Medium Low (2) | Medium Low (2) | Medium Low (2) | High (5) | High (5) | -- |
| PCE4B48 | 208/230-1-60 | Medium Low (2) | Medium Low (2) | Medium Low (2) | Medium (3) | Medium (3) | -- |
| PCE4B60 | 208/230-1-60 | Medium Low (2) | Medium Low (2) | Medium (3) | Medium (3) | Medium (3) | Medium (3) |

Table 14: Electric Heat Multipliers

| Voltage | | kW Capacity Multipliers ¹ |
|---------|---------|--------------------------------------|
| Nominal | Applied | |
| 240 | 208 | 0.75 |
| | 230 | 0.92 |

1. Electric heaters are rated at nominal voltage. Use this table to determine the electric heat capacity for heaters applied at lower voltages.

Table 15: Additional Static Resistance

| Size (ton) | CFM | Wet Indoor Coil | Economizer ¹ | Filter/Frame Kit |
|------------|------|-----------------|-------------------------|------------------|
| 24 (2.0) | 500 | 0.01 | 0.00 | 0.01 |
| | 600 | 0.01 | 0.00 | 0.02 |
| | 700 | 0.01 | 0.00 | 0.04 |
| | 800 | 0.02 | 0.01 | 0.06 |
| | 900 | 0.03 | 0.01 | 0.08 |
| | 1000 | 0.04 | 0.01 | 0.10 |
| | 1100 | 0.05 | 0.01 | 0.13 |
| | 1200 | 0.06 | 0.02 | 0.16 |
| 30 (2.5) | 700 | 0.01 | 0.00 | 0.04 |
| | 800 | 0.02 | 0.01 | 0.06 |
| | 900 | 0.03 | 0.01 | 0.08 |
| | 1000 | 0.04 | 0.01 | 0.10 |
| | 1100 | 0.05 | 0.01 | 0.13 |
| | 1200 | 0.06 | 0.02 | 0.16 |
| | 1300 | 0.07 | 0.03 | 0.17 |
| 36 (3.0) | 700 | 0.01 | 0.00 | 0.04 |
| | 800 | 0.02 | 0.01 | 0.06 |
| | 900 | 0.03 | 0.01 | 0.08 |
| | 1000 | 0.04 | 0.01 | 0.10 |
| | 1100 | 0.05 | 0.01 | 0.13 |
| | 1200 | 0.06 | 0.02 | 0.16 |
| | 1300 | 0.07 | 0.03 | 0.17 |
| | 1400 | 0.08 | 0.04 | 0.18 |
| 42 (3.5) | 1100 | 0.02 | 0.02 | 0.04 |
| | 1200 | 0.03 | 0.02 | 0.04 |
| | 1300 | 0.04 | 0.02 | 0.05 |
| | 1400 | 0.05 | 0.03 | 0.05 |
| | 1500 | 0.06 | 0.04 | 0.06 |
| | 1600 | 0.07 | 0.04 | 0.07 |
| | 1700 | 0.07 | 0.04 | 0.08 |
| | 1800 | 0.08 | 0.04 | 0.09 |
| | 1900 | 0.09 | 0.05 | 0.10 |
| 2000 | 0.09 | 0.05 | 0.11 | |
| 48 (4.0) | 1100 | 0.02 | 0.02 | 0.04 |
| | 1200 | 0.03 | 0.02 | 0.04 |
| | 1300 | 0.04 | 0.02 | 0.05 |
| | 1400 | 0.05 | 0.03 | 0.05 |
| | 1500 | 0.06 | 0.04 | 0.06 |
| | 1600 | 0.07 | 0.04 | 0.07 |
| | 1700 | 0.07 | 0.04 | 0.08 |
| | 1800 | 0.08 | 0.04 | 0.09 |
| | 1900 | 0.09 | 0.05 | 0.10 |
| | 2000 | 0.09 | 0.05 | 0.11 |
| 60 (5.0) | 1100 | 0.02 | 0.02 | 0.04 |
| | 1200 | 0.03 | 0.02 | 0.04 |
| | 1300 | 0.04 | 0.02 | 0.05 |
| | 1400 | 0.05 | 0.03 | 0.05 |
| | 1500 | 0.06 | 0.04 | 0.06 |
| | 1600 | 0.07 | 0.04 | 0.07 |
| | 1700 | 0.07 | 0.04 | 0.08 |
| | 1800 | 0.08 | 0.04 | 0.09 |
| | 1900 | 0.09 | 0.05 | 0.10 |
| 2000 | 0.09 | 0.05 | 0.11 | |

1. The pressure drop through the economizer is greater for 100% outdoor air than for 100% return air. If the resistance of the return air duct is less than 0.25 IWG, the unit delivers less CFM during full economizer operation.

Note: Filter pressure drop based on standard filter media tested at velocities not to exceed 300 ft/min.

SECTION VI: OPERATION

The following sequences of operation are based on using a single-stage air conditioning thermostat.

COOLING SEQUENCE OF OPERATION

- On a call for cooling, the wall thermostat sends a 24-V Y signal to the unit. The unit contactor closes, which energizes the outdoor fan and the compressor. The 24-V signal is also sent to the indoor blower motor, which runs at the selected cooling speed.
- When the demand for cooling is satisfied, the wall thermostat removes the 24-V Y signal from the unit. The contactor opens and the outdoor fan and the compressor stop. The indoor blower has a built-in delay and continues to run for 60 s after the cooling signal has been removed.

HEATING SEQUENCE OF OPERATION

Note: This section applies to units with an optional electric heat kit.

- On a call for heating, the wall thermostat sends a 24-V W signal to the unit. The indoor blower starts to run at the selected heating speed. The 24-V signal also goes to the sequencer(s) or relays in the electric heat kit and turns on the electric heating elements.
- When the demand for heating is removed, the wall thermostat removes the 24-V W signal. When the 24-V signal is removed from the electric heat sequencer, the heating elements turn off. The indoor blower continues to run for 60 s after the call for heat is removed.

Electric Heat Limit Switch Operation

When the limit switch opens, the heating elements turn off. The indoor blower continues to run. The limit switch automatically resets when the temperature falls to a normal level, at which time the heating elements are turned on again.

Table 16: Thermostat Signals

| Signal | State | Function |
|---------|--|---|
| G | ON | Indoor blower instant on |
| | OFF | Indoor blower off after 60-s delay |
| W | ON | Indoor blower instant on Electric heat stages on (if so equipped) |
| | OFF | Electric heat stages off (if so equipped) Indoor blower off after 60-s delay |
| G and W | ON | Indoor blower instant on in heating speed Electric heat stages on (if so equipped) |
| | W OFF | Electric heat stages off (if so equipped) Indoor blower switches to continuous fan speed |
| G and Y | ON | Outdoor fan on |
| | | Indoor blower instant on in cooling speed |
| | | Compressor on |
| | Y OFF | System operates in cooling mode |
| | | Compressor instant off |
| | Outdoor fan instant off | |
| | Indoor blower switches to continuous fan speed | |

Note: The motor program has a 60-s blower off delay on all five speed taps.

CHARGING

To check or adjust unit charge:

- Connect a temperature probe to the compressor discharge line approximately 6 in. away from the compressor shell.
- Connect a high side refrigerant pressure gauge to the unit discharge pressure port.
- Record discharge line temperature and discharge pressure. Using an R410A temperature pressure chart, convert gauge pressure to saturation temperature. The difference between discharge saturation temperature and discharge line temperature is discharge superheat.
- Obtain an entering indoor wet bulb temperature reading.
- Compare readings taken to the unit charging chart.

STARTING UP THE UNIT

1. Check the electrical supply voltage being supplied. Make sure that it is within the specified range on the unit data plate.
2. Make sure all electrical connections are tight.
3. If the unit is connected to 208-V supply power, wire the control transformer accordingly.
4. Turn on the electrical power to the unit.
5. Set the room thermostat to the COOL position and set the temperature setting on the thermostat lower than the room temperature to create a call for cooling.
6. Measure the total external static pressure and set the blower motor cooling speed appropriately as per the airflow performance tables.

7. If an optional electric heat kit is installed, make sure the W blower speed is set at or above the required speed. See Table 13.
8. Make sure that all the unit panels are in place and secured, and that an air filter is installed.

MEASURING EXTERNAL STATIC PRESSURE

1. Measure the supply air static pressure and record this positive number.
2. Measure the return air static pressure and record this negative number.
3. Treat the negative number as a positive and add the two numbers together. This is the total external static pressure.

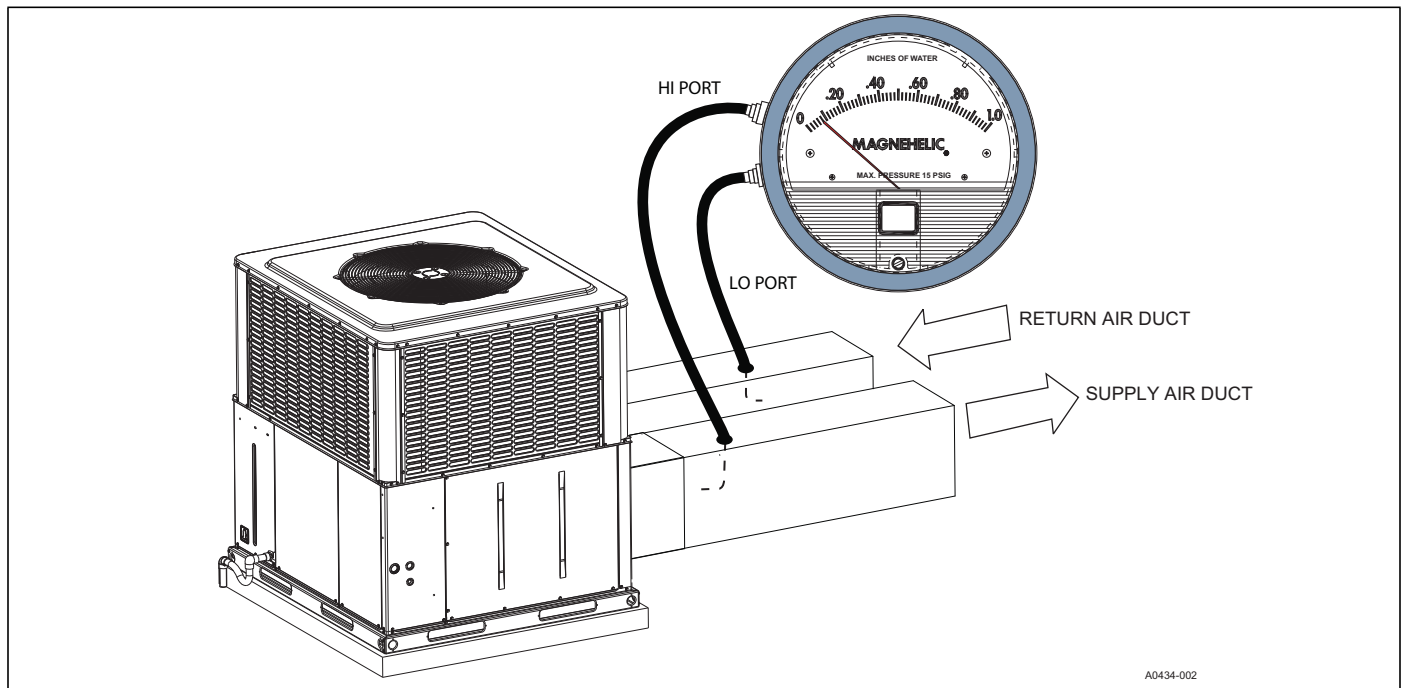

Figure 9: Measuring External Static Pressure

SECTION VII: MAINTENANCE

NORMAL MAINTENANCE

⚠ WARNING

Prior to any of the following maintenance procedures, shut off all power to the unit, to avoid personal injury.

Periodic maintenance consists of changing filters or cleaning filters and general cleaning of the outdoor coil.

Filters

Inspect filters once a month. Replace disposable filters or clean permanent filters as necessary.

Note: Do not replace permanent filters with disposable filters.

Motors

The indoor blower motor and outdoor fan motor are permanently lubricated and require no maintenance.

Outdoor Coil

Do not allow dirt to accumulate on the outdoor coil surface or other parts in the air circuit. Clean the coil as often as necessary to keep the coil clean. If using water to clean the coil, ensure that the power to the unit is shut off before cleaning.

NOTICE

DO NOT use a pressure washer as coil fin damage will occur.

⚠ CAUTION

Exercise care when cleaning the coil so that the coil fins are not damaged. Do not permit the hot outdoor air discharge outlet to be obstructed by overhanging structures or shrubs.

TROUBLESHOOTING

⚠ WARNING

Troubleshooting of components necessarily requires opening the electrical control box with the power connected to the unit. Use extreme care when working with live circuit! Check the unit nameplate for the correct range before making any connections with line terminals.

⚠ CAUTION

The wire number or color and terminal designations referred to may vary. Check the wiring label inside the control box access panel for the correct wiring.

SECTION VIII: TYPICAL WIRING DIAGRAMS

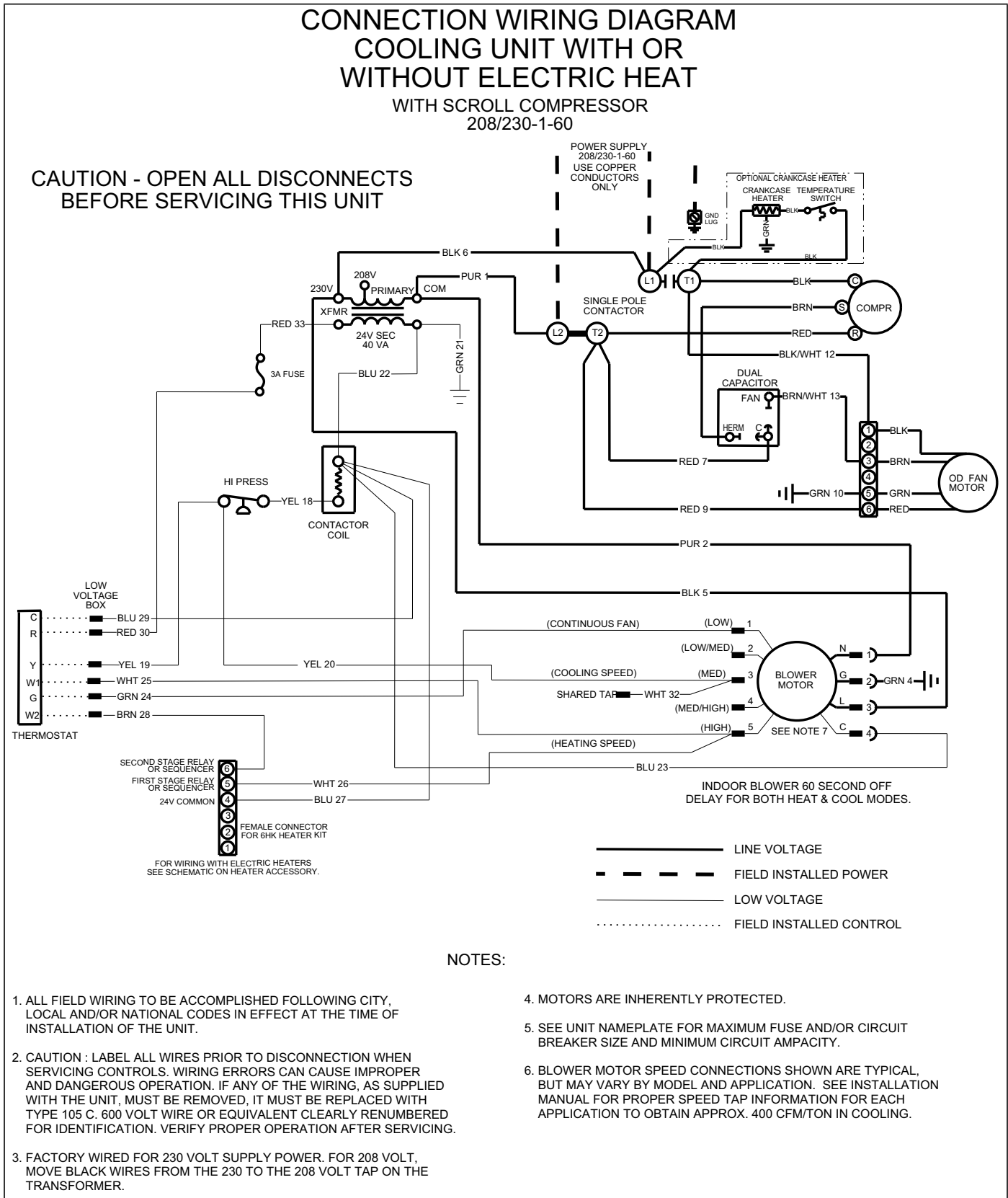
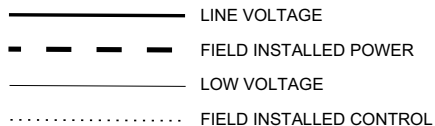

Figure 10: Connection Wiring Diagram

LADDER WIRING DIAGRAM COOLING UNIT WITH OR WITHOUT ELECTRIC HEAT

WITH SCROLL COMPRESSOR
208/230-1-60

**CAUTION - OPEN ALL DISCONNECTS
BEFORE SERVICING THIS UNIT**



NOTES:

1. ALL FIELD WIRING TO BE ACCOMPLISHED FOLLOWING CITY, LOCAL AND/OR NATIONAL CODES IN EFFECT AT THE TIME OF INSTALLATION OF THE UNIT.
2. CAUTION : LABEL ALL WIRES PRIOR TO DISCONNECTION WHEN SERVICING CONTROLS. WIRING ERRORS CAN CAUSE IMPROPER AND DANGEROUS OPERATION. IF ANY OF THE WIRING, AS SUPPLIED WITH THE UNIT, MUST BE REMOVED, IT MUST BE REPLACED WITH TYPE 105 C. 600 VOLT WIRE OR EQUIVALENT CLEARLY RENUMBERED FOR IDENTIFICATION. VERIFY PROPER OPERATION AFTER SERVICING.
3. FACTORY WIRED FOR 230 VOLT SUPPLY POWER. FOR 208 VOLT, MOVE BLACK WIRES FROM THE 230 TO THE 208 VOLT TAP ON THE TRANSFORMER.
4. MOTORS ARE INHERENTLY PROTECTED.
5. SEE UNIT NAMEPLATE FOR MAXIMUM FUSE AND/OR CIRCUIT BREAKER SIZE AND MINIMUM CIRCUIT AMPACITY.
6. BLOWER MOTOR SPEED CONNECTIONS SHOWN ARE TYPICAL, BUT MAY VARY BY MODEL AND APPLICATION. SEE INSTALLATION MANUAL FOR PROPER SPEED TAP INFORMATION FOR EACH APPLICATION TO OBTAIN APPROX. 400 CFM/TON IN COOLING.

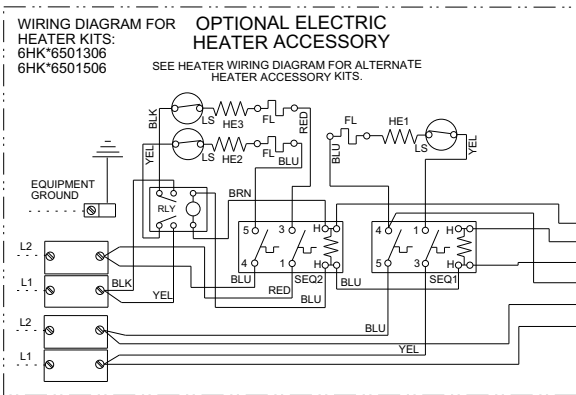
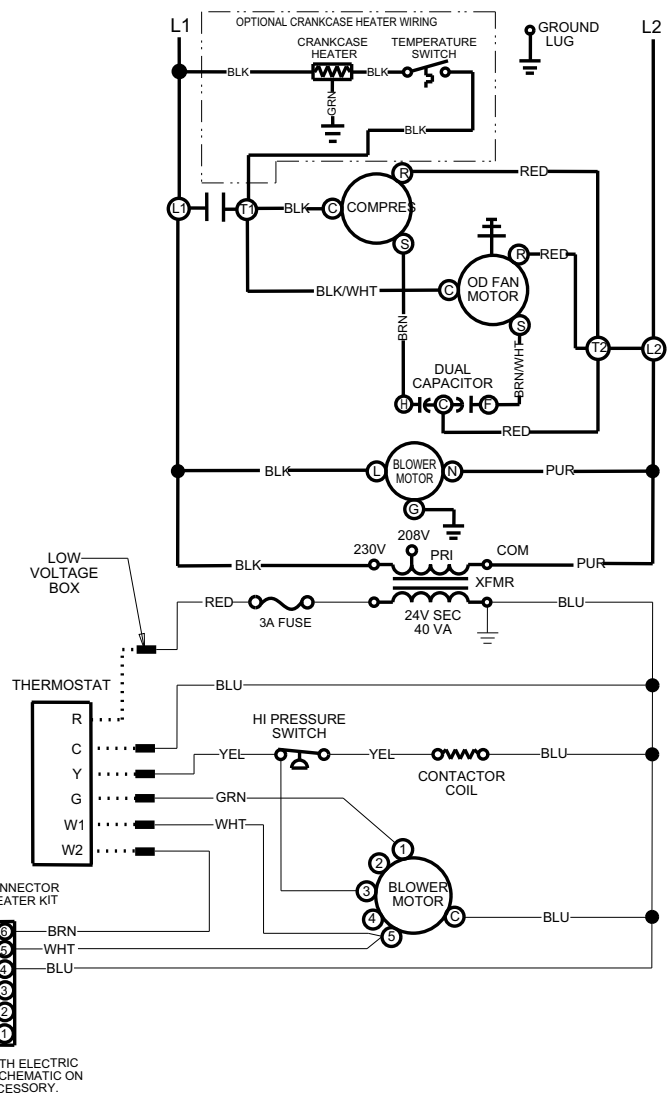

Figure 11: Ladder Wiring Diagram

R-410A QUICK REFERENCE GUIDE

Refer to Installation Instructions for specific installation requirements

- R-410A refrigerant operates at 50 - 70 percent higher pressures than R-22. Be sure that servicing equipment and replacement components are designed to operate with R-410A.
- R-410A refrigerant cylinders are rose colored.
- Recovery cylinder service pressure rating must be 400 psig, DOT 4BA400, or DOT BW400.
- Recovery equipment must be rated for R-410A.
- DO NOT use R-410A service equipment on R-22 systems. All hoses, gages, recovery cylinders, charging cylinders and recovery equipment must be dedicated for use on R-410A systems only.
- Manifold sets must be at least 700 psig high side, and 180 psig low side, with 550 psig retard.
- All hoses must have a service pressure rating of 800 psig.
- Leak detectors must be designed to detect HFC refrigerants.
- Systems must be charged with liquid refrigerant. Use a commercial type metering device in the manifold hose.
- R-410A can only be used with POE type oils.
- POE type oils rapidly absorb moisture from the atmosphere.
- Vacuum pumps will **not** remove moisture from R-410A refrigerant oils.
- Do not use liquid line driers with a rated working pressure rating less than 600 psig.
- Do not install suction line driers in the liquid line.
- A liquid line drier is required on every unit.
- Do not use a R-22 TXV. If a TXV is to be used, it must be a R-410A TXV.
- Never open system to atmosphere when under a vacuum.
- If system must be opened for service, evacuate system then break the vacuum with dry nitrogen and replace all filter driers.

Figure 12: R-410A Quick Reference Guide

SECTION IX: START-UP SHEET

[Print Form](#)

Residential Package Unit Cooling With Electric Heat Start-Up Sheet

[Reset Form](#)

Proper start-up is critical to customer comfort and equipment longevity

Start-Up Date Company Name Start-Up Technician

Owner Information

Name Address Daytime Phone
 City State or Province Zip or Postal Code

Equipment Data

Unit Model # Unit Serial #

General Information (Check all that apply)

| | | | |
|-----------------------------------|--|-----------------------------------|---------------------------------|
| <input type="radio"/> Residential | <input type="radio"/> New Construction | <input type="radio"/> Roof level | <input type="radio"/> Down flow |
| <input type="radio"/> Commercial | <input type="radio"/> Retrofit | <input type="radio"/> Grade level | <input type="radio"/> Side flow |

Unit Location and Connections (Check all that apply)

Unit is level and installed on: Slab Roof curb Duct connections are complete: Supply Return
 Condensate drain properly connected per the installation instructions Condensate trap has been primed with water

Filters

Filters installed Number of filters Filter size Filter located inside Filter located outside

Additional Kits & Accessories Installed (Check all that apply)

Refrigerant safety kit Low ambient kit Anti-recycle timer Crank case heater Filter frame kit
 Transformer kit Economizer Roof curb kit Burglar bar kit Hail guard kit
 Manual fresh air damper kit Motorized fresh air damper kit

Electrical Connections & Inspection (Check all that apply)

Single phase Three phase 208 volts AC 230 volt AC 460 volts AC 575 volts AC
 Inspect wires and electrical connections Transformer wired properly for primary supply voltage Ground connected
 Low voltage present at control board "R & C" Measured voltage "R" and "C" outdoor unit control board
 Line voltage present at disconnect Measured voltage "L1 to L2" "L2 to L3" "L1 to L3"
 Compressor amperes "L1" "L2" "L3" Total amperes "L1" "L2" "L3"
 Single stage compressor Two stage compressor

Air Flow Setup / Cooling

| | | |
|---------------------------------|--|--|
| Blower Type & Set-Up | <input type="radio"/> ECM | COOL <input type="radio"/> A <input type="radio"/> B <input type="radio"/> C <input type="radio"/> D |
| | | ADJUST <input type="radio"/> A <input type="radio"/> B <input type="radio"/> C <input type="radio"/> D |
| | | DELAY <input type="radio"/> A <input type="radio"/> B <input type="radio"/> C <input type="radio"/> D |
| | <input type="radio"/> X-13 <input type="radio"/> 1 <input type="radio"/> 2 <input type="radio"/> 3 <input type="radio"/> 4 <input type="radio"/> 5 | |
| | <input type="radio"/> PSC <input type="radio"/> Low <input type="radio"/> Medium Low <input type="radio"/> Medium <input type="radio"/> Medium High <input type="radio"/> High | |

| | | |
|---|--|---|
| Supply static (inches of water column) <input type="text"/> | Supply air dry bulb temperature <input type="text"/> | Outside air dry bulb temperature <input type="text"/> |
| Return static (inches of water column) <input type="text"/> | Return air dry bulb temperature <input type="text"/> | Return air wet bulb temperature <input type="text"/> |
| Total external static pressure <input type="text"/> | Temperature drop <input type="text"/> | Supply air wet bulb temperature <input type="text"/> |

Refrigerant Charge and Metering Device

| | | | |
|---|---|---|--|
| <input type="radio"/> R-410A <input type="radio"/> R-22 | Data plate - lbs / Oz <input type="text"/> | Suction line temperature <input type="text"/> | Discharge pressure <input type="text"/> |
| <input type="radio"/> TXV <input type="radio"/> Fixed Orifice | Discharge line temperature <input type="text"/> | Suction pressure <input type="text"/> | Liquid line temperature <input type="text"/> |
| TXV# / Orifice size <input type="text"/> | | Superheat <input type="text"/> | Subcooling <input type="text"/> |

Electric Heat

| | | | | |
|--|--|---|-------------------------------|-------------------------------|
| Electric heat kit - Model number <input type="text"/> | Serial number <input type="text"/> | Rated KW <input type="text"/> | | |
| <input type="radio"/> Single Phase | Measured Amperage | Heater 1 <input type="text"/> | Heater 2 <input type="text"/> | Heater 3 <input type="text"/> |
| <input type="radio"/> Three Phase | | Heater 4 <input type="text"/> | Heater 5 <input type="text"/> | Heater 6 <input type="text"/> |
| Number of elements <input type="text"/> | Measured Voltage | Heater 1 <input type="text"/> | Heater 2 <input type="text"/> | Heater 3 <input type="text"/> |
| | | Heater 4 <input type="text"/> | Heater 5 <input type="text"/> | Heater 6 <input type="text"/> |
| Heating return air dry bulb temperature <input type="text"/> | Heating supply air dry bulb temperature <input type="text"/> | Air temperature rise <input type="text"/> | | |

Clean Up Job Site

| |
|--|
| <input type="checkbox"/> Job site has been cleaned, indoor and outdoor debris removed from job site <input type="checkbox"/> Tools have been removed from unit <input type="checkbox"/> All panels have been installed |
|--|

Unit Operation and Cycle Test

| |
|---|
| <input type="checkbox"/> Operate the unit through continuous fan cycles from the thermostat, noting and correcting any problems <input type="checkbox"/> Operate the unit through cooling cycles from the thermostat, noting and correcting any problems |
|---|

Owner Education

| |
|--|
| <input type="checkbox"/> Provide owner with the owner's manual <input type="checkbox"/> Explain operation of system to equipment owner <input type="checkbox"/> Explain thermostat use and programming (if applicable) to owner <input type="checkbox"/> Explain the importance of regular filter replacement and equipment maintenance |
|--|

Comments and Additional Job Details