

SUBMITTAL DATA SHEET

LX SERIES SPLIT SYSTEM AIR CONDITIONERS 14 SEER – R-410A – 1 PHASE – 1.5 THRU 5 NOMINAL TONS MODELS: TC4B18 THRU 60

JOB NAME:			LOCATION:		
PURCHASER:			ORDER NO:		
ENGINEER:					
SUBMITTED TO:	FOR:	REF:	APPROVAL:	CONSTRUCTION:	
SUBMITTED BY:			DATE:		
UNIT DESIGNATION:			SCHEDULE NO.	MODEL NO.	

PRODUCT DATA

Cooling Performance

Total Capacity _____ MBH
Outdoor Design Temp _____ °F

Electrical Data

Power Supply _____ / _____ / _____
Compressor Ampacity _____ AMPs
Total Unit Ampacity _____ AMPs
Power Input Req _____ KW
Minimum Wire Size _____ AWG
Maximum Overcurrent Device
 Fuses Circuit Breaker

Unit Weight

Unit Weight _____ LBS

DIMENSIONS - INCHES

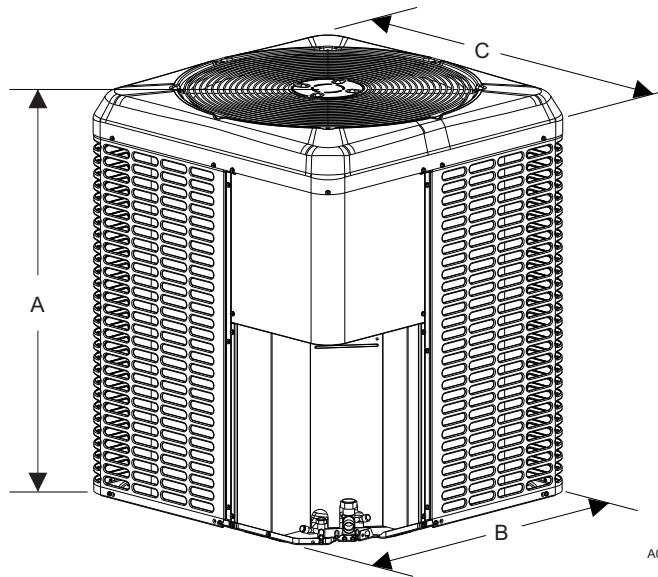

A0339-001

DIMENSIONS

Unit Model	Dimensions (Inches)			Refrigerant Connection Service Valve Size	
	A	B	C	Liquid	Vapor
TC4B1822S	30	24	24	3/8	3/4
TC4B2422S	26-3/4	29-1/4	29-1/4		
TC4B3022S	26-3/4	29-1/4	29-1/4		
TC4B3622S	30	29-1/4	29-1/4		7/8
TC4B4222S	36-1/4	29-1/4	29-1/4		
TC4B4821S	33-1/4	35-1/4	31-3/4		
TC4B6021S	36-1/4	38	34-1/4	7/8 [‡]	

[‡] Adapter fitting must be field installed for the required 1-1/8" line set.
All dimensions are in inches and are subject to change without notice.
Overall height is from bottom of base pan to top of fan guard.
Overall length and width include screw heads.



FEATURES

- **Small Footprint** - Minimum footprint for easier handling, transportation, and installation.
- **Easier Installation** - Independent panels provide quick access for unit setup. Installation time is reduced by easy power and control wiring access. Select indoor matches with factory-mounted TXVs are available for quicker system installation. The factory installed filter-drier and factory charge for a 15-Ft lineset means less time spent brazing and charging the system. The small base dimension and reduced unit clearances make for easier retrofits.
- **Accessible Information** - QR code on unit provides quick access to technical documents and warranty information.
- **Durable Finish** - The coated steel wire fan guard, coated external fasteners, and pre-treated G90-equivalent galvanized steel chassis components resist corrosion and rust creep. Titanium colored powdercoat paint further protects external panels.
- **Quality Coils** - The high efficiency microchannel aluminum coil is manufactured using an improved material system providing reliable performance and small unit size.
- **Rugged Coil Protection** - Coils are protected from mechanical damage by a proven stamped steel coil guard design.
- **Protected Compressor** - Compressors are protected internally by a high pressure relief valve and a temperature sensor, and externally by the system high pressure switch. The liquid line filter-drier is factory installed to protect the compressor against moisture and debris.
- **Reliable Operation** - Ball bearing fan motors provide superior performance in extreme temperatures.
- **Environmentally Friendly** - CFC-free R-410A refrigerant delivers environmentally friendly performance with zero ozone depletion.
- **Top Discharge** - Warm air is blown up, away from the structure and any landscaping and allows compact location on multi-unit applications.
- **Low Operating Sound Levels** - Developed using CFD and FEA tools, the sturdy cabinet and top design provides sound performance of 76 dBA or lower. Compatible accessories for further sound reduction are also available.
- **Better Service Access** - Diagonal base valves with open access for low-loss fittings, single panel access to the electrical controls, swing out control box for full corner access, and removable fan guard allow easy access for unit maintenance.
- **Agency Listed** - Safety certified by CSA to UL 1995 / CSA 22.2. Performance certified to ANSI/AHRI Standard 210/240 in accordance with the Unitary Small Equipment certification program.

WARRANTY SUMMARY*

Standard 5-Years limited parts warranty.

Standard 10-Years limited compressor warranty.

Extended 10-Years limited parts warranty when product is registered online within 90 days of purchase for replacement or closing for new home construction.

*Does not apply to R-22 models, 3-Phase models, or Internet sales. See Limited Warranty certificate in User's Information Manual for details.

TYPICAL CLEARANCES

The minimum clearances for a typical installation are shown below. See the Technical Guide for alternate installations.

- 10" Clearance Coil Area
- 48" Overhead Clearance
- 18" Minimum Service Panel Access
- 24" Minimum Unit to Unit Distance

MATCHING AIR SIDE EQUIPMENT

Model No. _____

Submittal Form No. _____

FIELD INSTALLED ACCESSORIES

Off Cycle Time Delay (S1-2TD08700124)

Standard Low Ambient Control (S1-2LA06700424)

Advanced Low Ambient Control (S1-2LA04701024)

Low Pressure Switch Kit (S1-2PS06700524)

Compressor Start Assist (S1-2SA067_____)*

Compressor Crankcase Heater (S1-025_____)*

Support Feet (S1-HPRKIT-_____)*

Anchor Bracket Kit (S1-1HK0401)

Indoor TXV Kit (S1-1TVM_____)*

Wall Mount Kit (S1-ACB-_____)*

Compressor Sound Blanket (S1-010076_____)*

* See price pages for accessory information.

Refer to Technical Guide for detailed specifications on the unit and its accessories.

Verify the actual ratings for each specific matchup in the online AHRI directory at www.ahridirectory.org at the time of bid or sale. It is also recommended to print the rating certificate, if needed, at the time of bid or sale.