

# Installation Manual: Z8ES Single-Stage Standard ECM Residential Gas Furnaces (Non-condensing Multi-position Standard and Low NOx)

York International Corp. 5005 York Drive  
Norman, OK 73069

[www.johnsoncontrols.com](http://www.johnsoncontrols.com)

2023-03-23

6100758-UIM-B-0323

Rev B



# Contents

General.....	5	Vent system.....	22
Certification.....	5	Vent connections.....	22
Safety.....	5	Category 1 - 450°F maximum vent temperature.....	23
Specific safety rules and precautions.....	6	Venting.....	23
Safety requirements.....	7	Venting into an existing chimney.....	23
Combustion air quality (list of contaminants).....	7	Fan-assisted combustion system.....	23
Codes and standards.....	8	Ambient combustion air supply.....	23
For furnaces installed in the Commonwealth of Massachusetts only.....	8	Dampers, louvers and grilles (Canada only).....	25
Inspection.....	9	.....	25
Ductwork.....	10	Ventilated combustion air.....	26
Ductwork general information.....	10	Vent and supply (outside) air safety check procedure.....	26
Duct flanges.....	11	Start-up and adjustments.....	27
Ductwork installation and supply plenum connection - upflow/horizontal.....	11	Removing NOx screens (Lo-NOx models only).....	27
Floor base and ductwork installation - downflow.....	11	Gas piping leak check.....	28
Coil installation.....	12	Ignition system sequence.....	28
Downflow duct connectors.....	13	Calculating the furnace input (natural gas).....	28
Residential and modular home upflow return plenum connection.....	13	.....	29
Side return application.....	13	Adjusting the manifold gas pressure and input rate.....	30
Bottom return and attic installations.....	13	Airflow settings.....	31
Downflow application.....	13	Safety controls.....	34
Horizontal application.....	13	Control circuit fuse.....	34
Attic installation.....	13	Blower door safety switch.....	34
Suspended furnace or crawl space installation.....	14	Rollout switch controls.....	34
Filters.....	16	Pressure switches.....	34
Filter installation.....	16	Limit controls.....	35
Side return.....	16	Sequence of operation.....	35
Gas piping.....	17	Troubleshooting.....	35
Gas safety.....	17	Furnace control diagnostics.....	36
Gas piping installation.....	17	Diagnostic fault code storage and retrieval.....	37
Gas orifice conversion for propane (LP).....	18	Replacement parts list.....	38
High altitude gas orifice conversion.....	18	Replacement part contact information.....	38
High altitude pressure switch conversion.....	19	Wiring diagram.....	39
Electric power.....	19	Start-up sheet.....	41
Electric power connections.....	19		
Supply voltage connections.....	20		
Low voltage control wiring connections.....	20		
Accessory connections.....	21		
Electronic air cleaner connection.....	21		
Humidifier connection.....	21		
Twinning and staging.....	21		
Furnace control twinning wiring.....	21		
Twinning duct system.....	22		



## General

These high efficiency, compact units employ induced combustion, reliable hot surface ignition and high heat transfer aluminized steel tubular heat exchangers. The units are factory-shipped for installation in upflow or horizontal applications and may be converted for downflow applications.

These furnaces are designed for residential installation in a basement, closet, alcove, attic, recreation room, or garage and are also ideal for commercial applications. All units are factory-assembled, wired, and tested to ensure safe, dependable, and economical installation and operation.

These units are Category I listed and can be common-vented with another gas appliance in accordance with the National Fuel Gas Code.

## Certification



Assembled at a facility with an ISO 9001:2015-certified Quality Management System



## Safety



This is a safety alert symbol. When you see this symbol on labels or in manuals, be alert to the potential for personal injury.

Understand and pay particular attention to the signal words **DANGER**, **WARNING**, or **CAUTION**.

**DANGER** indicates an **imminently** hazardous situation, which, if not avoided, **will result in death or serious injury**.

**WARNING** indicates a **potentially** hazardous situation, which, if not avoided, **could result in death or serious injury**.

**CAUTION** indicates a **potentially** hazardous situation, which, if not avoided **may result in minor or moderate injury**. It is also used to alert against unsafe practices and hazards involving only property damage.

### **WARNING**

Improper installation may create a condition where the operation of the product could cause personal injury or property damage. Improper installation, adjustment, alteration, service or maintenance can cause injury or property damage. **Failure to carefully read and follow all instructions in this manual can result in furnace malfunction, death, personal injury and/or property damage.** Only a qualified contractor, installer or service agency should install this product.

### **WARNING**

This system should be installed by personnel certified by Johnson Controls, Inc. Personnel must be qualified according to local, state, and national building and safety codes and regulations. Incorrect installation could cause leaks, electric shock, fire or explosion. Additionally, in N.A., the US EPA regulations (40 CFR Part 82, Subpart F) under Section 608 of the Clean Air Act requires that technicians who maintain, service, repair, or dispose of equipment that could release refrigerants into the atmosphere must be certified.

### **WARNING**

Perform the test run in its entirety to ensure normal operation. Safety guards, shields, barriers, covers, and protective devices must be in place while the compressor/unit is operating. During the test run, keep fingers and clothing away from any moving parts. Clean up the site when finished, remembering to check that no metal scraps or bits of wiring have been left inside the unit being installed. After installation work for the system has been completed, explain the Safety Precautions, use, and maintenance of the unit to the customer according to the information in all manuals that accompanied the system. All manuals and warranty information must be given to the user or left near the Indoor Unit.

## WARNING

- Check that the ground wire is securely connected. Do not connect ground wiring to gas piping, water piping, lighting conductor, or telephone ground wiring.
- If a circuit breaker, fuse or safety sensor is frequently activated, i.e. rapid red flashes, shut down the system and contact your service contractor. Please follow all instructions provided in this manual. Any disregard of the steps outlined in this manual is taken at the user's own risk.

## WARNING

- Unauthorized modifications to Johnson Controls products are prohibited as they:
- may create hazards which could result in death, serious injury or equipment damage.
  - will void product warranties.
  - may invalidate product regulatory certifications.
  - may violate OSHA standards.

## WARNING

Use appropriate personal protective equipment, such as gloves and protective goggles and, where appropriate, have a gas mask nearby. Also, use electrical protection equipment and tools suited for electrical operation purposes. Do not touch or adjust any safety devices inside the indoor or outdoor units. All safety features, disengagement, and interlocks must be in place and functioning correctly before the equipment is put into operation. If these devices are improperly adjusted or tampered with in any way, a serious accident can occur. Never bypass or wire around any safety device.

### Specific safety rules and precautions

- Only natural gas or propane (LP) gas are approved for use with this furnace.
- Only install this furnace in a location and position as specified in this manual.
- Only install a gas-fired furnace in a residential garage as specified in this manual.
- Provide adequate combustion and ventilation air to the furnace space as specified in this manual.

- Only discharge combustion products outdoors. Only connect this furnace to an approved vent system, as specified in this manual.
- Test for gas leaks as specified in this manual.

## WARNING

### FIRE OR EXPLOSION HAZARD

Failure to follow the safety warnings exactly could result in serious injury, death, or property damage. Never test for gas leaks with an open flame. Use a commercially available soap solution made specifically for detection of leaks to check all connections. A fire or explosion may result causing property damage, personal injury, or loss of life.

- Always install the furnace to operate within the furnace's intended temperature rise range. Only connect the furnace to a duct system that has an external static pressure within the allowable range, as specified on the furnace rating plate.
- When installing a furnace so that supply ducts carry air circulated by the furnace to areas outside the space containing the furnace, handle the return air with ducts sealed to the furnace casing and terminating outside the space containing the furnace.
- It is permitted to use the furnace to heat buildings or structures under construction where the application and use comply with all installation instructions in this manual, including:
  - Adequate vent installation
  - The furnace operating under thermostatic control
  - The return air duct sealed to the furnace
  - Air filters in place
  - The furnace input rate and temperature rise set according to the rating plate marking
  - Means for providing the outside air required for combustion
  - The return air temperature maintained between 55°F (13°C) and 80°F (27°C)
  - **Replacing the air filter** after substantial completion of the construction process
  - Cleaning the furnace, duct work, and components after substantial completion of the construction process, and verifying furnace-operating conditions, including ignition, input rate, temperature rise, and venting.
- When installing in a non-HUD-Approved Modular Home or building constructed on-site, do not supply combustion air from occupied spaces.

- Base the size of the unit on an acceptable heat loss calculation for the structure. Use ACCA Manual J or another approved method.
- When moving or handling the furnace before installation, always leave the doors on the furnace to provide support and to prevent damage or warping of the cabinet. When lifting the furnace by the cabinet, support the ends of the furnace rather than lifting by the cabinet flanges at the bottom or side return air openings or supply air opening.
- When lifting the furnace, you can use the primary heat exchanger tubes as a lifting point provided that you lift the tubes at the front of the heat exchangers where they are attached to the vestibule panel. Do not use the top return bend of the heat exchangers as lifting points as the tubes may shift out of position.
  - **Important:** Doors must remain on the furnace when moving or lifting during installation.

## Safety requirements

### CAUTION

This product must be installed in strict compliance with the installation instructions and any applicable local, state, and national codes including, but not limited to, building, electrical, and mechanical codes.

- Refer to the unit rating plate for the furnace model number and then see for return air plenum dimensions. You must install the plenum according to the instructions.
- Provide clearances from combustible materials as listed under Table 1.
- Provide clearances for servicing. Ensure to allow service access for both the burners and the blower.
- These models **are not** CSA listed or approved for installation into a **HUD Approved Modular Home** or a **Manufactured (Mobile) Home**.
- This furnace is not approved for installation in trailers or recreational vehicles.
- Do not install furnaces on combustible flooring directly on carpeting, tile, or other combustible material, other than wood flooring.
- Check the rating plate and power supply to be sure that the electrical characteristics match. All models use nominal 115 VAC, single-phase, 60 Hz power supply. **Do not connect this appliance to a 50 Hz power supply or a voltage above 130 V.**
- Install the Furnace so that the electrical components are protected from water.

- Installing and servicing heating equipment can be hazardous due to the electrical components and the gas-fired components. Only trained and licensed personnel must install, repair, or service gas heating equipment. Unlicensed service personnel can perform basic maintenance functions such as cleaning and replacing the air filters. When working on heating equipment, observe precautions in the manuals and on the labels attached to the unit, and other safety precautions that apply.

## Combustion air quality (list of contaminants)

### WARNING

The furnace area must not be used as a broom closet or for any other storage purposes, as a fire hazard may be created. Never store items such as the following on, near, or in contact with the furnace:

- Spray or aerosol cans, rags, brooms, dust mops, vacuum cleaners or other cleaning tools.
- Soap powders, bleaches, waxes or other cleaning compounds, plastic items or containers, gasoline, kerosene, cigarette lighter fluid, dry cleaning fluids or other volatile fluid.
- Paint thinners and other painting compounds.
- Paper bags, boxes or other paper products.

**Never operate the furnace with the blower door removed. To do so could result in serious personal injury and/or equipment damage.**

The furnace requires **outdoor air** for combustion when locating the furnace in any of the following environments:

- Buildings with indoor pools
- Chemical exposure
- Commercial buildings
- Hobby or craft rooms
- Laundry rooms
- Installation near chemical storage areas
- Restricted environments

The furnace requires **outdoor air** for combustion when the furnace is located in an area where the furnace is being exposed to the following substances or chemicals:

- Antistatic fabric softeners for clothes dryers
- Carbon tetrachloride
- Cements and glues
- Chlorine based swimming pool chemicals
- Chlorinated waxes and cleaners
- Cleaning solvents such as perchloroethylene
- De-icing salts or chemicals

- Halogen type refrigerants
- Hydrochloric acid
- Masonry acid washing materials
- Permanent wave solutions
- Printing inks, paint removers, varnishes, and similar substances
- Water softening chemicals

When using outdoor air for combustion, you must locate the combustion air intake duct system termination external to the building and in an area where there is no exposure to the substances listed above.

## Codes and standards

Follow all national and local codes and standards in addition to this installation manual. The installation must comply with regulations of the serving gas supplier, local building, heating, plumbing, and other codes. In the absence of local codes, the installation must comply with the national codes listed below and all authorities having jurisdiction.

In the United States and Canada, follow all codes and standards for the following, using the latest edition available:

### Safety

- United States: National Fuel Gas Code (NFGC) NFPA 54/ANSI Z223.1 and the Installation Standards, Warm Air Heating and Air Conditioning Systems ANSI/NFPA 90B
- Canada: CSA B149.4 National Standard of Canada. Natural Gas and Propane Installation Codes (NSCNGPIC)

### General installation

- United States: Current edition of the NFGC and NFPA 90B. For copies, contact the National Fire Protection Association Inc. Batterymarch Park Quincy, MA 02269 or for only the NFGC, contact the American Gas Association, 400 N. Capital, N.W. Washington DC 20001 or <http://www.NFPA.org>
- Canada: NSCNGPIC. For a copy, contact: Standard Sales, CSA International 178 Rexdale Boulevard Etobicoke, (Toronto) Ontario, Canada M9W 1R5

### Combustion and ventilation air

- United States: Section 5.3 of the NFGC, air for Combustion and Ventilation
- Canada: Part 7 of NSCNGPIC, Venting Systems and Air Supply for Appliances

## Duct systems

- United States and Canada: Air Conditioning Contractors Association (ACCA) Manual D, Sheet Metal and Air Conditioning Contractors Association National Association (SMACNA), or American Society of Heating, Refrigeration, and Air Conditioning Engineers (ASHRAE) 1997 Fundamentals Handbook Chapter 32.

## Acoustical lining and fibrous glass duct

- United States and Canada: Current edition of SMACNA and NFPA 90B as tested by UL Standard 181 for Class I Rigid Air Ducts

## Gas piping and gas pipe pressure testing

- United States: NFGC, Chapters 2, 3, 4, and 9, and National Plumbing Codes
- Canada: NSCNGPIC Part 5

## Electrical connections

- United States: National Electrical Code (NEC) ANSI/NFPA 70
- Canada: Canadian Electrical Code CSA C22.1

These instructions cover minimum requirements and conform to existing national standards and safety codes. In some instances, these instructions exceed certain local codes and ordinances, especially those that do not reflect changing residential and non-HUD modular home construction practices. These instructions are required as a minimum for a safe installation.

## For furnaces installed in the Commonwealth of Massachusetts only

For all side wall horizontally vented gas-fueled equipment installed in every dwelling, building, or structure used in whole or in part for residential purposes, including those owned or operated by the Commonwealth and where the side wall exhaust vent termination is less than seven (7) feet above finished grade in the area of the venting, including but not limited to decks and porches, the following requirements shall be satisfied:



1. **Installation of carbon monoxide detectors** - At the time of installation of the side wall horizontal vented gas fueled equipment, the installing plumber or gasfitter shall observe that a hard wired carbon monoxide detector with an alarm and battery back-up is installed on the floor level where the gas equipment is to be installed. In addition, the installing plumber or gasfitter shall observe that a battery operated or hard wired carbon monoxide detector with an alarm is installed on each additional level of the dwelling, building or structure served by the side wall horizontal vented gas fueled equipment. It shall be the responsibility of the property owner to secure the services of qualified licensed professionals for the installation of hard wired carbon monoxide detectors.
  - a. In the event that the side wall horizontally vented gas fueled equipment is installed in a crawl space or an attic, the hard wired carbon monoxide detector with alarm and battery back-up may be installed on the next adjacent floor level.
  - b. In the event that the requirements of this subdivision can not be met at the time of completion of installation, the owner shall have a period of thirty (30) days to comply with the above requirements; provided, however, that during said thirty (30) day period, a battery operated carbon monoxide detector with an alarm shall be installed.
2. **Approved carbon monoxide detectors** - Each carbon monoxide detector as required in accordance with the above provisions shall comply with NFPA 720 and be ANSI/UL 2034 listed and IAS certified.
3. **Signage** - A metal or plastic identification plate shall be permanently mounted to the exterior of the building at a minimum height of eight (8) feet above grade directly in line with the exhaust vent terminal for the horizontally vented gas fueled heating appliance or equipment. The sign shall read, in print size no less than one-half (1/2) inch in size, "**GAS VENT DIRECTLY BELOW. KEEP CLEAR OF ALL OBSTRUCTIONS**".
4. **Inspection** - The state or local gas inspector of the side wall horizontally vented gas fueled equipment shall not approve the installation unless, upon inspection, the inspector observes carbon monoxide detectors and signage installed in accordance with the provisions of 248 CMR 5.08(2)(a)1 through 4.

## Inspection

Immediately after receiving the unit, inspect for possible damage during transit. If damage is evident, note the

extent of the damage on the carrier's freight bill. Make a separate request for inspection by the carrier's agent in writing. Also, before installation, check the unit for any screws or bolts that loosened in transit. You do not need to remove any shipping or spacer brackets from the interior of this unit.

## Furnace location and clearances

Choose a location to install the furnace using the following guidelines:

- Where a minimum amount of air intake or vent piping and elbows is required
- As centralized with the air distribution as possible
- Where adequate combustion air is available, particularly when the appliance is not using outdoor combustion air
- Where the furnace does not interfere with adequate air circulation in the confined space

## Installation in freezing temperatures

- Install the furnace in an area where ventilation facilities provide for safe limits of ambient temperature under normal operating conditions.



### WARNING

Improper installation in a room with an ambient temperature below 32°F (0.0°C) such as a garage or attic, could create a hazard, resulting in damage, injury, or death.

- Do not allow the return air temperature to be below 55° F (13°C) for extended periods. To do so may cause condensation to occur in the main heat exchanger, leading to premature heat exchanger failure.

### Clearances for access or service:

Provide ample clearances for easy access to the unit. The following are the minimum clearances required:

- 24 in. (61 cm) between the front of the furnace and an adjacent wall or another appliance, to provide access for servicing and cleaning
- 18 in. (46 cm) at the side where access is required for passage to the front when servicing, or for inspection or replacement of flue or vent connections

In all cases, accessibility clearances take precedence over clearances for combustible materials where accessibility clearances are greater.

### Installation in a residential garage

When installing a gas-fired furnace in a residential garage, ensure the burners and the ignition source are at least 18 in. (46 cm) above the floor and the furnace is in a location that avoids physical damage by vehicles.

**Table 1: Unit clearances to combustibles**

Application	Top	Front	Rear	Left side	Right side	Flue	Floor or bottom	Closet	Alcove	Attic	Line contact
	in. (cm)	in. (cm)	in. (cm)	in. (cm)	in. (cm)	in. (cm)	in. (cm)				
Upflow	1 (2.5)	1 (2.5)	0	0	0	6 (15.2)	Combustible	Yes	Yes	Yes	No
Upflow B-Vent	1 (2.5)	1 (2.5)	0	0	0	1 (2.5)	Combustible	Yes	Yes	Yes	No
Downflow	1 (2.5)	1 (2.5)	0	0	0	6 (15.2)	1 (25.4)	Yes	Yes	Yes	No
Downflow B-Vent	1 (2.5)	1 (2.5)	0	0	0	1 (2.5)	1 (25.4)	Yes	Yes	Yes	No
Horizontal	1 (2.5)	1 (2.5)	0	0	0	6 (15.2)	Combustible	No	Yes	Yes	Yes
Horizontal B-Vent	1 (2.5)	1 (2.5)	0	0	0	1 (2.5)	Combustible	No	Yes	Yes	Yes

**Note:**

- All surfaces are identified with the unit in an upflow configuration.
- **For downflow applications:** a combustion floor base accessory or an air conditioning coil is required for use on a combustible floor.
- **For horizontal applications:** line contact is only permitted between lines formed by the intersection of the rear panel and side panel (top in horizontal position) of the furnace jacket and building joists, studs, or framing.

## Ductwork

### Ductwork general information

The duct system's design and installation must adhere to the following:


- The system must handle an air volume appropriate for the served space and within the operating parameters of the furnace specifications.
- Installation must be in accordance with the National Fire Protection Association as outlined in NFPA standard 90B (latest editions) or applicable national, provincial, state, and local fire and safety codes.
- It must create a closed duct system. For residential and non-HUD Modular Home installations, when installing a furnace so that the supply ducts carry air circulated by the furnace to areas outside the space containing the furnace, handle the return air with ducts sealed to the furnace casing and terminating outside the space containing the furnace.
- Complete a path for heated or cooled air to circulate through the air conditioning and heating equipment, and to and from the conditioned space.

to avoid condensation in the primary heat exchanger. When using a parallel flow arrangement, dampers or other means used to control airflow must be adequate to prevent chilled air from entering the furnace. If manually operated, equip the damper with means to prevent the furnace or the air conditioner from operating unless the damper is in full heat or cool position.

When replacing an existing furnace, if the existing plenum is not the same size as the new furnace then remove the existing plenum and install a new plenum that is the correct size for the new furnace. If the plenum is shorter than 12 in. (30.5 cm), the turbulent airflow may cause the limit controls not to operate as designed or the limit controls may not operate at all.

The duct system is a very important part of the installation. **If the duct system is incorrectly sized, the furnace does not operate correctly.** The ducts attached to the furnace plenum must be of sufficient size so that the furnace operates at the specified external static pressure and within the air temperature rise specified on the nameplate.

- **Important:** The minimum plenum height is 12 in. (30.5 cm). The furnace does not operate correctly on a shorter plenum height. The minimum rectangular duct height is 4 in. (10.2 cm) attached to the plenum.

 **CAUTION**

You must install the indoor coil in the supply air duct, downstream of the furnace. Do not pass cooled air over the heat exchanger.

When using the furnace with an indoor coil, install the coil parallel with or on the supply air side of the furnace

## ⚠ WARNING

The duct system must be correctly sized to obtain the correct airflow for the furnace size that is being installed.

Refer to the furnace rating plate for the correct rise range and static pressures or to Table 5 for the correct rise range.

If the duct system is undersized, the result will be high external static pressures and/or high temperature rises which can result in a heat exchanger **overheating condition**. This condition can result in premature heat exchanger failure, which can result in personal injury, property damage, or death.

If using a matching cased indoor coil, it is possible to place it directly on the furnace outlet and seal it to prevent leakage. If installing an uncased indoor coil with a thermoplastic drain pan in the upflow/horizontal configuration, then provide an extra 2 in. (5.1 cm) minimum spacing to ensure against drain pan distortion. On all installations without an indoor coil, use a removable access panel in the outlet duct so that smoke or reflected light are observable inside the casing, which indicates the presence of leaks in the heat exchanger. Ensure to attach this access panel securely to prevent leaks.

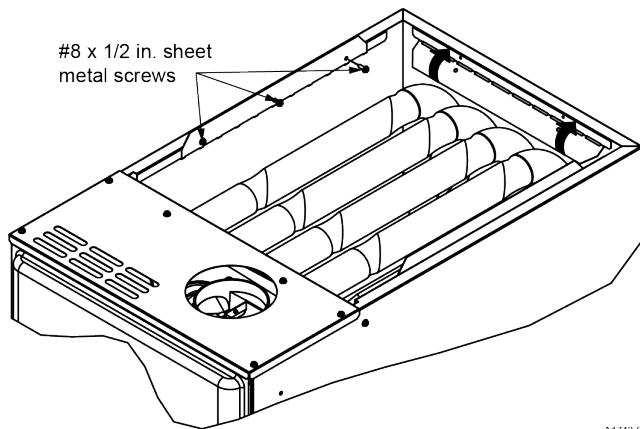
### Duct flanges

Three duct flanges are part of the furnace casing. To use these duct flanges, do the following:

1. Fold the flanges upward along the slots until the flanges contact the casing flange.
2. Secure each flange to the casing using #8 x 1/2 in. screws (not provided) in the holes provided.

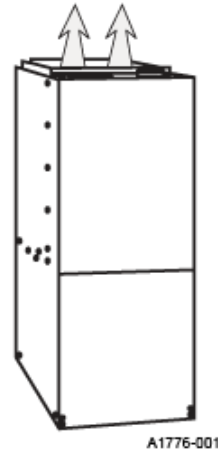
If not using the flanges, they must remain in the down position as shipped.

**Figure 1: Duct attachment**



## Ductwork installation and supply plenum connection - upflow/horizontal

**Figure 2: Ductwork installation and supply plenum connection - upflow/horizontal**



To install the ductwork and supply plenum connection in the upflow/horizontal configuration, follow the steps below:

1. Attach the supply plenum to the furnace outlet. Use an approved flexible duct connector on all installations.
2. Ensure that you seal the connection to prevent air leakage.
3. Use crosshatched sheet metal to eliminate any popping of the sheet metal when the indoor fan is energized.

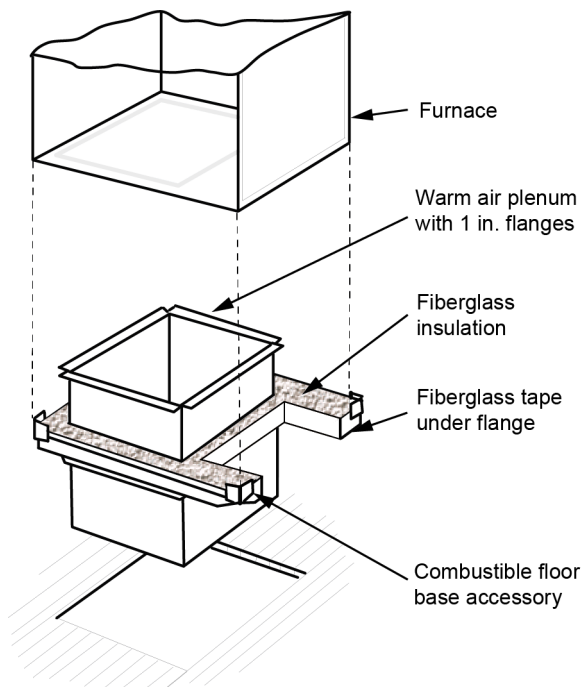
## Floor base and ductwork installation - downflow

**Figure 3: Floor base and ductwork installation - downflow**



Use a combustible floor base for installations on combustible material or directly on any floors, as shown in Figure 4. Follow the instructions supplied with the combustible floor base accessory. It is possible to replace this combustible floor base with a matching indoor coil, correctly sealed to prevent leaks. Follow the instructions supplied with the indoor coil cabinet for installing the cabinet to the duct connector. Plug vent pipe hole in the bottom panel.

**Figure 4: Combustible floor base accessory**



A0732-002

### Downflow air - indoor coil cabinet

Install the furnace with a coil cabinet specifically intended for downflow application. If using a matching indoor coil, it is possible to place it directly on the furnace outlet and seal it to prevent leakage. For details of the coil cabinet dimensions and installation requirements, refer to the installation instructions supplied with the coil cabinet.

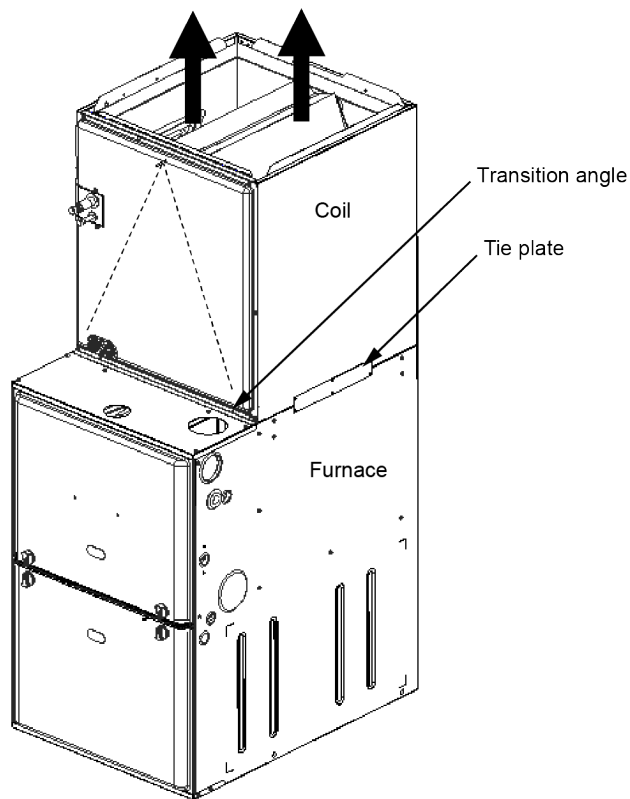
Attach the indoor coil cabinet to the duct connector and then position the furnace on top of the coil cabinet. Seal the connection to the furnace, coil cabinet, duct connector, and supply air duct to prevent air leakage.

### Coil installation

► **Important:** On all installations without a coil, use a removable access panel in the outlet duct so that smoke or reflected light are observable inside the casing, which indicates the presence of leaks in the heat exchanger. Ensure to attach this access panel securely to prevent leaks.

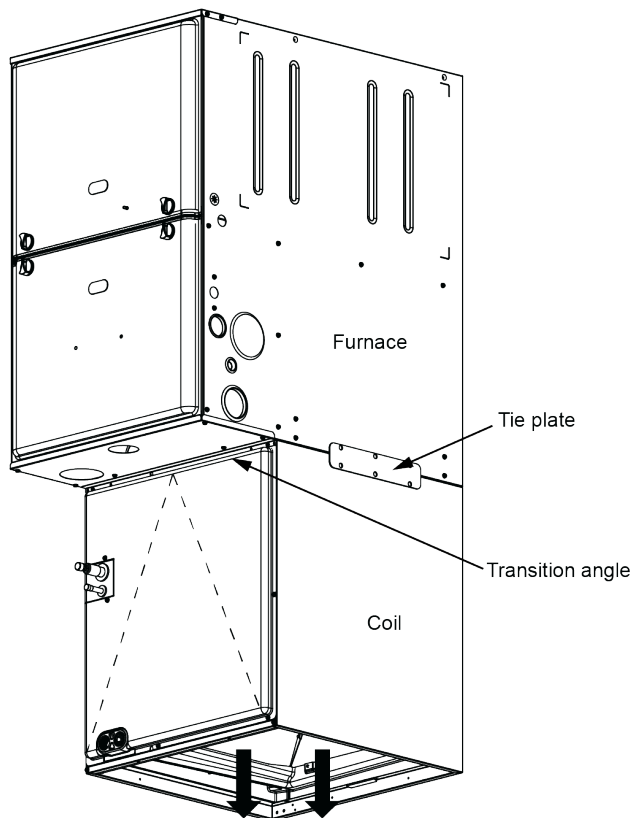
Mount the indoor coil on the supply side of the furnace as shown in Figure 5 to Figure 8. Refer to the installation instructions provided with each indoor coil.

**Figure 5: Vertical upflow applications with furnaces**



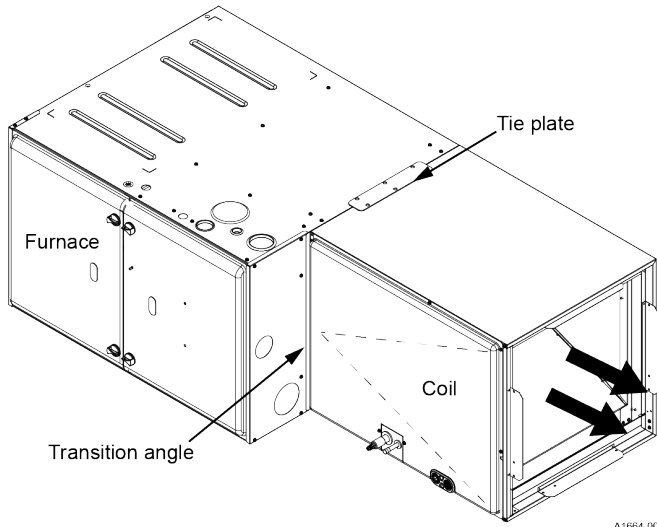
A1659-001

**Figure 6: Vertical downflow applications with furnaces**

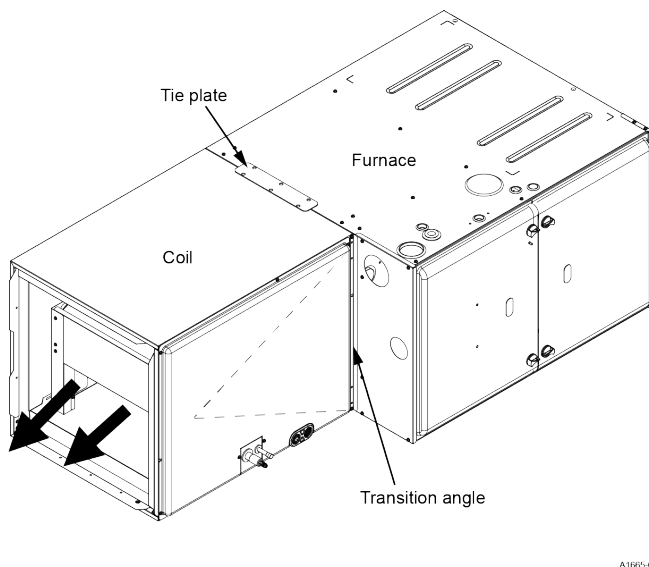


A1660-001

**Figure 7: XAH horizontal right application with furnace**



**Figure 8: XAH horizontal left application with furnace**



### Downflow duct connectors

All downflow installations must use a suitable duct connector approved by the furnace manufacturer for use with this furnace. The duct connectors are designed to connect to the rectangular duct under the floor and sealed. Refer to the instructions supplied with the duct connector for correct installation.

### Residential and modular home upflow return plenum connection

Return air may enter the furnace through the sides or bottom depending on the type of application. Do not connect return air into the rear panel of the unit.

### Side return application

Side return applications pull return air through an opening cut in the side of the furnace casing. The furnace is supplied with a bottom blockoff panel that must be left in place if using a side return. If installing the furnace on a flat, solid surface, this bottom panel provides an adequate seal to prevent air leakage through the unused bottom opening. However, if installing the furnace on a surface that is uneven or if installing on blocks or otherwise raised off the floor, it is necessary to seal the edges of the bottom panel to the casing using tape or other appropriate gasket material to prevent air leakage.

### Bottom return and attic installations

Bottom return applications normally pull return air through a base platform or return air plenum. Ensure the return platform structure or return air plenum is suitable to support the weight of the furnace. The internal bottom panel must be removed for this application.

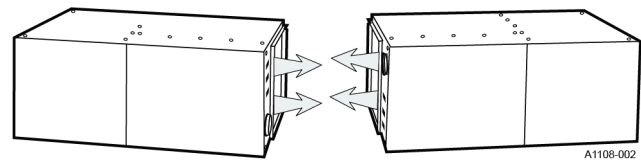
Attic installations must meet all minimum clearances to combustibles and have floor support with the required service accessibility.

### Downflow application

For downflow applications, turn the furnace upside down so the circulating air enters the furnace at the top and exits the furnace at the bottom. Rotate the combustion air inducer 90° as shown in Figure 24. **Do not block the combustion air inlet openings.**

### Horizontal application

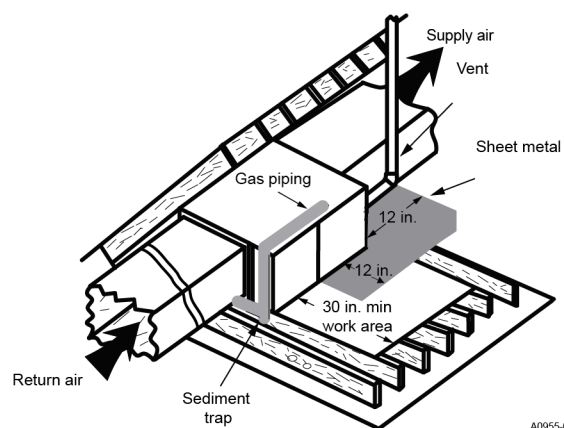
**Figure 9: Horizontal application**



**Important:** It is possible to install this furnace in a horizontal position on either side as shown above. **Do not install this furnace on its back.**

### Attic installation

**Figure 10: Typical attic installation**



This appliance is certified for line contact when installing in the horizontal left or right position. The line contact is only permissible between lines that are formed by the intersection of the top and two sides of the furnace and the building joists, studs, or framing. This line may be in contact with combustible material. The filter rack must be a minimum distance of 18 in. (45.7 cm) from the furnace. Maintain required clearances to combustibles. See Figure 10.

**WARNING**

When a furnace is installed in an attic or other insulated space, keep all insulating materials at least 12 in. (30.5 cm) away from furnace and burner combustion air openings.

► **Important:** During installation, doors must remain on the furnace when moving or lifting.

When moving or handling this furnace before installation, always leave the doors on the furnace to provide support and to prevent damage or warping of the cabinet. When lifting the furnace, support the ends of the furnace rather than lifting by the cabinet flanges at the return air openings, bottom or sides, or supply air opening.

It is acceptable to use the primary heat exchanger tubes as a lifting point, provided that you lift the tubes at the front of the heat exchangers where attached to the vestibule panel. Do not use the top return bend of the heat exchangers as lifting points, as the tubes may shift out of position, or out of their location brackets or baffles.

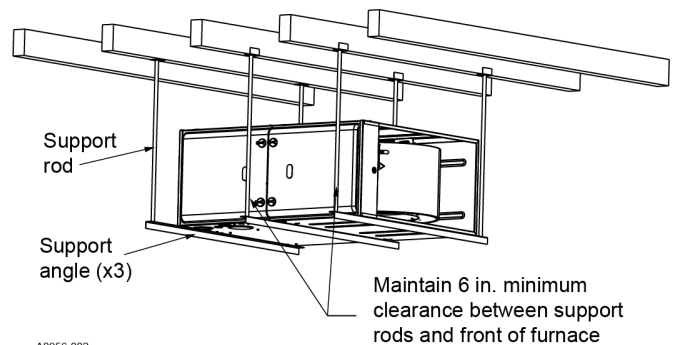
## Suspended furnace or crawl space installation

It is possible to hang the furnace from floor joists or install it on suitable blocks or pads. Ensure blocks or pad installations provide adequate height so that the unit is not subject to water damage.

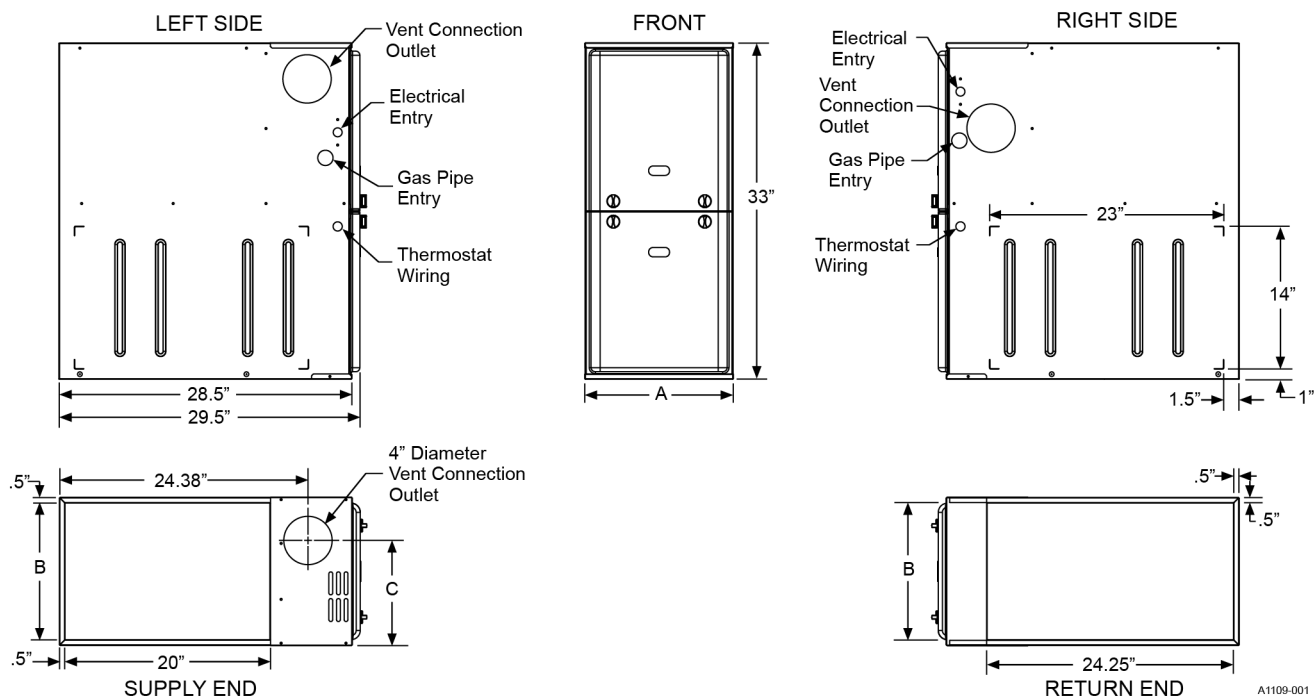
You can also suspend units from rafters or floor joists using rods, pipe angle supports, or straps. In all cases, you must support the furnace with rods, straps, or angle supports at three locations to adequately support the furnace. Place one support at the supply end of the furnace, one support in the center of the furnace near the blower shelf, and the third support at the return end of the furnace. Maintain a 6 in. (15.2 cm) minimum clearance between the front of the furnace and the support rods or straps.

All six suspension points must be level to ensure correct and quiet furnace operation. When suspending the furnace, use a secure platform constructed of steel angle iron or unistrut secured to the floor or ceiling joists. See Figure 11 for details and additional information.

**Figure 11: Typical suspended furnace or crawl space installation**



**Figure 12: Dimensions**



A1109-001

**Table 2: Cabinet and duct dimensions**

Btu/h (kW) input	Nominal CFM (m <sup>3</sup> /min)	Cabinet size	A (in.)	A (cm)	B (in.)	B (cm)	C (in.)	C (cm)	Approximate operating weight (lb)
40 (11.7)	1200 (34.0)	A	14 1/2	36.8	13 3/8	34.0	10.3	26.2	89
60 (17.6)	1200 (34.0)	A	14 1/2	36.8	13 3/8	34.0	10.3	26.2	94
80 (23.4)	1200 (34.0)	B	17 1/2	44.4	16 3/8	41.6	11.8	29.9	103
80 (23.4)	1600 (45.3)	C	21	53.3	19 7/8	50.5	13.6	34.5	116
80 (23.4)	2000 (56.6)	C	21	53.3	19 7/8	50.5	13.6	34.5	121
100 (29.3)	1200 (34.0)	B	17 1/2	44.4	16 3/8	41.6	11.8	29.9	108
100 (29.3)	1600 (45.3)	C	21	53.3	19 7/8	50.5	13.6	34.5	120
100 (29.3)	2000 (56.6)	C	21	53.3	19 7/8	50.5	13.6	34.5	124
120 (35.1)	1600 (45.3)	C	21	53.3	19 7/8	50.5	15.8	40.1	125
120 (35.1)	2000 (56.6)	C	21	53.3	19 7/8	50.5	15.8	40.1	131
130 (38.1)	2000 (56.6)	D	24.5	62.2	23 3/8	59.4	17.5	44.4	137

## Filters

### Filter installation

#### CAUTION

All installations must have a filter installed. All filters and mounting provision must be field-supplied. Unauthorized modifications to Johnson Controls products are prohibited as they may create hazards which could result in equipment damage.

All applications require the use of a field-installed filter. All filters and mounting provision must be field-supplied.

Install filters external to the furnace cabinet. **Do not attempt to install filters inside the furnace.**

**Table 3: Required minimum filter sizes (high velocity 600 FPM)**

CFM (m <sup>3</sup> /min)	Cabinet size	Side (in.)	Bottom (in.)
1200 (34.0)	A	16 x 25	14 x 25
1200 (34.0)	B	16 x 25	16 x 25
1600 (45.3)	C	16 x 25	20 x 25
2000 (56.6)	C	(2) 16 x 25	20 x 25
2000 (56.6)	D	(2) 16 x 25	22 x 25

- Air velocity through disposable-type filters may not exceed 300 ft/min (91.4 m/min). All velocities over this require the use of high velocity filters.
- Do not exceed 1800 CFM using one side return and a 16 x 25 filter. For CFM greater than 1800, you may use two side returns, one side and the bottom, or one side return with a transition to allow use of a 20x25 filter.

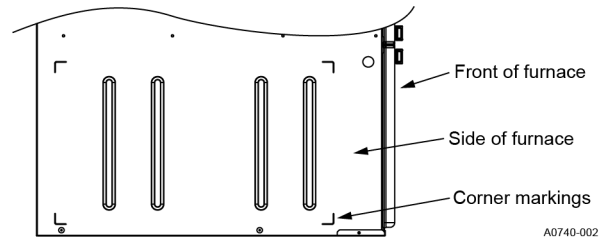
#### NOTICE

Single side return above 1800 CFM is approved as long as the filter velocity does not exceed filter manufacturer's recommendation and a transition is used to allow use on a 20x25 filter.

### Side return

Locate the L shaped corner locators. These indicate the size of the cutout to make in the furnace side panel as shown in Figure 13.

**Figure 13: Side return cutout markings**



Install the side filter rack following the instructions provided with that accessory. If one or more filters are provided at another location in the return air system, attach the ductwork directly to the furnace side panel.

- Important:** Some accessories such as electronic air cleaners and pleated media may require a larger side opening. Follow the instructions supplied with that accessory for side opening requirements. **Do not** cut the opening larger than the dimensions for the optional return air cutout shown in Figure 12.

### Horizontal filters

#### CAUTION

In horizontal furnace arrangement, the filter must be located a minimum of 18 in. from the return air inlet of furnace.

Any branch duct (rectangular or round duct) attached to the plenum must attach to the vertical plenum before the filter. It is important to use straps and supports as required to support the weight of the external filter box.

### Downflow filters

#### CAUTION

In downflow furnace arrangement, the filter must be located a minimum of 12 in. from the return air inlet of furnace.

Downflow furnaces are typically installed with the filters located above the furnace, extending into the return air plenum or duct. Any branch duct (rectangular or round duct) attached to the plenum must attach to the vertical plenum above the filter height. Filters may be located in the duct system external to the furnace using an external duct filter box attached to the furnace plenum or at the end of the duct in a return filter grille.

Use straps and supports as required to support the weight of the external filter box.



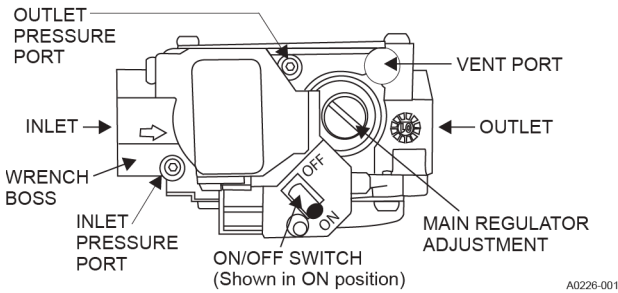
# Gas piping

## Gas safety

### **WARNING**

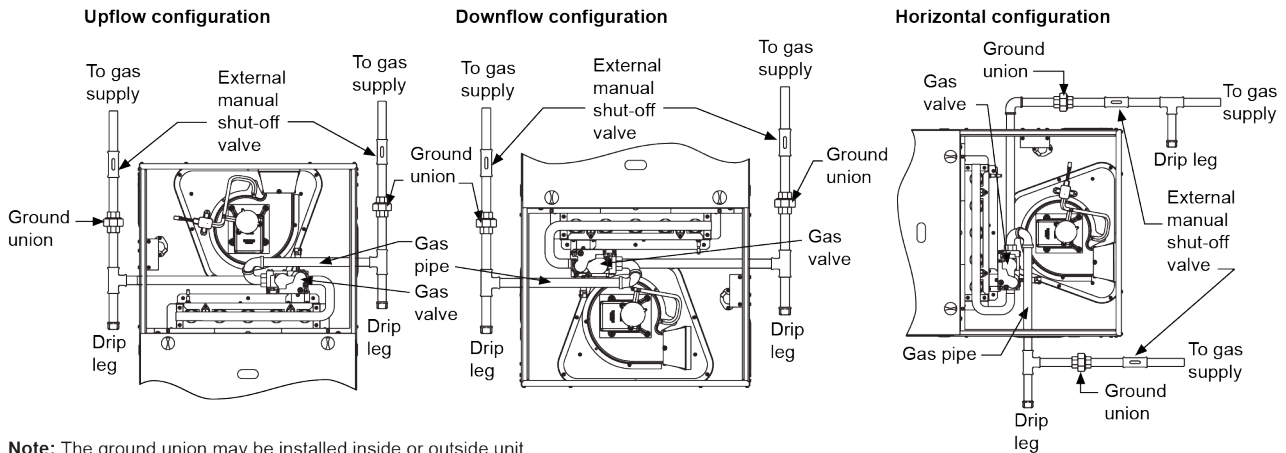
An overpressure protection device, such as a pressure regulator, must be installed in the gas piping system upstream of the furnace and must act to limit the downstream pressure to the gas valve so it does not exceed 0.5 psig (14 in. W.C., 3.48 kPa). Pressures exceeding 0.5 psig (14 in. W.C., 3.48 kPa) at the gas valve can damage the gas valve and subsequently the furnace or some of its components, leading to possible gas-related fire, explosion, property damage, and loss of life.

**Figure 14: Gas valve**



A0226-001

**Figure 15: Supply gas pipe arrangement**



**Note:** The ground union may be installed inside or outside unit.

A1794-001

► **Important:** Plan the gas supply routing before determining the correct gas pipe entry. Use 90° conventional elbows and short pipe nipples to enter through the cabinet access holes.

## Gas piping installation

You must use correctly sized wrought iron, approved flexible or steel pipe when making gas connections to the unit. If local codes allow the use of a flexible gas appliance connection, always use a new listed connector. Do not use a connector that has previously serviced another gas appliance.

Some utility companies or local codes require pipe sizes larger than the minimum sizes listed in these instructions and in the codes. The furnace rating plate and the instructions in this section specify the type of gas approved for this furnace - only use those approved gases. The installation of a drip leg and ground union is required. See Figure 15.

► **Important:** You must install an accessible manual shutoff valve upstream of the furnace gas controls and within 6 ft (1.8 m) of the furnace.

You must isolate the furnace from the gas supply piping system by closing its individual external manual shutoff valve during any pressure testing of the gas supply piping system at pressures equal to or less than 1/2 psig (3.5 kPa).

**CAUTION**

The gas valve body is a very thin casting that cannot take any external pressure. Never apply a pipe wrench to the body of the gas valve when installing piping. A wrench must be placed on the octagon hub located on the gas inlet side of the valve. Placing a wrench to the body of the gas valve will damage the valve causing improper operation and/or the valve to leak.

**CAUTION**

Burner ignition may not be satisfactory on first startup due to residual air in the gas line or until gas manifold pressure is adjusted. The ignition control makes three attempts to light before locking out. After three trials for ignition, if the appliance does not operate, follow the instructions Turning off the appliance in the User's Information Manual and call your gas supplier to verify the quality and/or consistency of the gas supply. If the gas supply has been verified and/or other gas appliances are operating properly, and the appliance still does not ignite, call service to properly troubleshoot the unit.

It is possible to connect gas piping from either side of the furnace using any of the gas pipe entry knockouts on both sides of the furnace. See Figure 15.

**Gas orifice conversion for propane (LP)**

This furnace is factory-made for natural gas-fired operation, but it is possible to convert it to operate

**Table 4: Nominal Manifold Pressure**

Gas heating value (Btu/ft <sup>3</sup> )	Manifold pressures (in. W.C.) at different altitude ranges (ft)			Gas heating value (MJ/m <sup>3</sup> )	Manifold pressures (kPa) at different altitude ranges (m)		
	0-7999	8000-8999	9000-9999		0-2437	2438-2742	2743-3048
800	3.5	3.5	3.5	29.8	0.87	0.87	0.87
850	3.5	3.5	3.5	31.7	0.87	0.87	0.87
900	3.5	3.5	3.5	33.5	0.87	0.87	0.87
950	3.5	3.5	3.3	35.4	0.87	0.87	0.81
1000	3.5	3.2	2.9	37.3	0.87	0.80	0.73
1050	3.5	2.9	2.7	39.1	0.87	0.73	0.67
1100	3.2	2.7	2.4	41.0	0.80	0.66	0.61
2500 (LP)	9.8	8.2	7.5	93.2 (LP)	2.44	2.03	1.86

on propane (LP) gas by using a factory-supplied LP conversion kit. Follow the instructions supplied with the LP kit.

**WARNING**

LoNOx furnaces requiring propane (LP) gas must have the LoNOx screens removed prior to installation and operation. Refer to the propane kit conversion instructions.

**WARNING**

Examine the burner flames to make sure they are in good adjustment. Look to a pure blue flame with a light blue cone at its center that burns full, steady and straight. If yellow or orange, or a partial, diverted, or unsteady flame is detected, then turn off gas valves and clean any debris from nozzles and pilot light. If condition still exists, then check airflow, venting, gas pressure, etc. If condition still exists, contact technical service for further instructions.

**High altitude gas orifice conversion**

This furnace is factory-made for natural gas-fired operation at 0 ft to 5,000 ft (0 m to 1,524 m) above sea level.

To maintain correct and safe operation, it is essential to change the manifold pressure when installing the furnace in a location where the altitude is greater than 5,000 ft (1,524 m) above sea level. See Table 4 for the correct manifold pressure settings.



## WARNING

### PROPANE AND HIGH ALTITUDE CONVERSION KITS

The installer must take every precaution to insure that the furnace has been converted to the proper gas orifice size when the furnace is installed. It is very important to choose the correct kit and/or gas orifices for the altitude and the type of gas for which the furnace is being installed.

High altitude conversions are required in order for the appliance to satisfactorily meet those applications. Only use natural gas in furnaces designed for natural gas. Only use propane (LP) gas for furnaces that have been properly converted to use propane (LP) gas. Do not use this furnace with butane gas.

Incorrect gas orifices or a furnace that has been improperly converted creates an extremely dangerous condition that results in premature heat exchanger failure, excessive sooting, high levels of carbon monoxide, personal injury, property damage, and potential for fire hazard and/or death.

An authorized distributor or dealer must make all gas conversions. In Canada, a certified conversion station or other qualified agency, using factory specified and/or approved parts, must perform the conversion.

Do not attempt to drill out any orifices to obtain the proper orifice size. Drilling out a gas orifice will cause misalignment of the burner flames, causing premature heat exchanger burnout, high levels of carbon monoxide, excessive sooting, a fire hazard, personal injury, property damage and/or death.

## High altitude pressure switch conversion

For installation where the altitude is less than 5,000 ft (1,524 m), it is not required to change the pressure switch unless you are in an area subject to low pressure inversions.

## Electric power

### Electric power connections

Field wiring to the unit must be grounded. Electric wires that are field-installed must conform to the temperature limitation for 63°F (35°C) rise wire when installed in accordance with instructions. See Table 5 for specific furnace electrical data.



## CAUTION

Use copper conductors only.

**Table 5: Ratings and Physical/Electrical Data**

Input		Output		Nominal airflow		AFUE	Air temperature rise		Maximum outlet air temperature		Blower		Blower size	Recommended fuse or circuit breaker	Total unit	Gas pipe connection, NPT
MBH	kW	MBH	kW	CFM	m <sup>3</sup> /min	%	°F	°C	°F	°C	HP	A	in.	A	A	in.
40	11.7	32	9.4	1200	34.0	80	20-50	11-28	190	88	1/2	6.4	11 x 8	15	8.2	1/2
60	17.6	48	14.1	1200	34.0	80	30-60	17-33	190	88	1/2	6.4	11 x 8	15	8.2	1/2
80	23.5	64	18.8	1200	34.0	80	35-65	19-36	190	88	1/2	6.4	11 x 8	15	8.7	1/2
80	23.5	64	18.8	1600	45.3	80	30-60	17-33	190	88	1/2	6.4	11 x 10	15	8.8	1/2
80	23.5	64	18.8	2000	56.6	80	25-55	14-31	190	88	1	11.5	11 x 11	20	13.8	1/2
100	29.3	80	23.4	1200	34.0	80	40-70	22-39	190	88	1/2	6.4	11 x 8	15	8.7	1/2
100	29.3	80	23.4	1600	45.3	80	40-70	22-39	190	88	3/4	8.8	11 x 10	15	11.1	1/2
100	29.3	80	23.4	2000	56.6	80	25-55	14-31	190	88	1	11.5	11 x 11	20	13.8	1/2
120	33.7	96	26.9	1600	45.3	80	40-70	22-39	190	88	3/4	8.8	11 x 10	15	11.1	1/2
120	33.7	96	26.9	2000	56.6	80	35-65	19-36	190	88	1	11.5	11 x 11	20	13.7	1/2
130	38.1	104	30.5	2000	56.6	80	35-65	19-36	190	88	1	11.5	11 x 11	20	13.7	1/2

### ⓘ Note:

- Annual Fuel Utilization Efficiency (AFUE) numbers are determined in accordance with DOE test procedures.

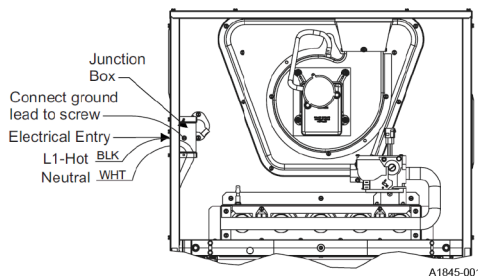
- Wire size and overcurrent protection must comply with the National Electrical Code (NFPA-70-latest edition) and all local codes.
- Install the furnace so that the electrical components are protected from water.

## Supply voltage connections

1. Provide a power supply separate from all other circuits. Install overcurrent protection and a disconnect switch in accordance with local and national electrical codes. Locate the switch close to the unit for convenience in servicing.
2. With the disconnect or fused switch in the OFF position, check all wiring against the unit wiring label. See the wiring diagram in this manual.
3. Remove the wiring box cover screws.
4. Route all power wiring through a conduit connector or other proper bushing that is field-installed into the unit opening and the junction box. In the junction box, there is a black wire, a white wire, and a green ground screw.
  - a. Connect the power supply as shown on the unit's wiring label located on the inside of the blower compartment door or the wiring schematic in this section.
  - b. Connect the black wire to L1 (hot) from the power supply.
  - c. Connect the white wire to neutral.
  - d. Connect the installer-supplied ground wire to the green equipment ground screw.

An alternate wiring method is to use a field-provided 2 in. x 4 in. (5.1 cm x 10.2 cm) box and cover on the outside of the furnace. Route the furnace leads into the box using a protective bushing where the wires pass through the furnace panel. After making the wiring connections replace the wiring box cover and screws. See Figure 16.

**Figure 16: Electrical wiring**



5. The furnace's control system requires correct polarity of the power supply and an adequate ground connection. See Figure 16.
  - **Important:** It is possible to relocate the power connection leads and wiring box to the opposite side of the furnace. Remove the screws and cut wire tie holding excess wiring. Reposition on the opposite side of the furnace and fasten using the holes provided.

## Low voltage control wiring connections

Install the field-supplied thermostat by following the instructions that come with the thermostat. With the thermostat set in the OFF position and the main electrical source disconnected, connect the thermostat wiring from the wiring connections on the thermostat to the terminal block on the control board, as shown in Figure 17 to Figure 20. Electronic thermostats require the common wire to be connected. Do not use power-stealing thermostats. Apply strain relief to thermostat wires passing through cabinet. If air conditioning equipment is installed, use thermostat wiring to connect the Y and C terminals on the furnace control board to the correct wires on the condensing unit (unit outside).

- **Important:** Set the heat anticipator in the room thermostat to 0.4 A. Setting it lower causes short cycles. Setting it higher causes the room temperature to exceed the set points.
- **Important:** Some electronic thermostats do not have adjustable heat anticipators. Set these to six cycles per hour. Follow the thermostat manufacturer's instructions.

The 24 V, 40 VA transformer is sized for the furnace components only, and must not be connected to power auxiliary devices such as humidifiers and air cleaners. The transformer may provide power for an air conditioning or heat pump contactor.

### NOTICE

**For Figure 17 and Figure 18:**

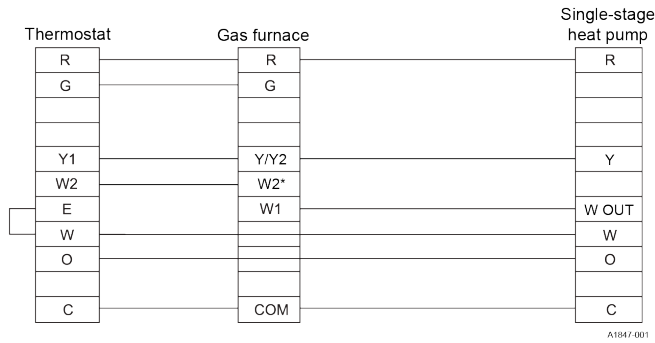
- Do not bond any of the outdoor unit W wires together.
- W2 input is only available on two-stage gas heat models.
- Fossil fuel operation must be controlled by the room thermostat.

### NOTICE

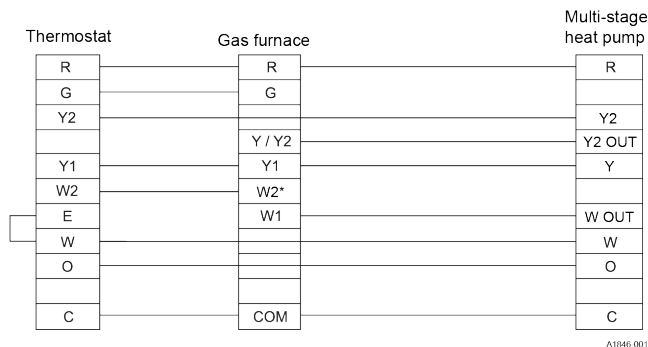
**For Figure 20:**

If the outdoor section DEMAND RESPONSE feature is used, connect the room thermostat Y2 connection directly to the outdoor unit and the outdoor unit Y2 OUT connection to the furnace Y/Y2 input.

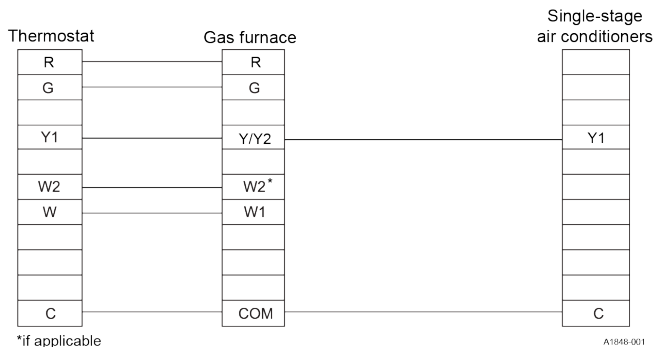
**Figure 17: Standard ECM furnace and single-stage HP**



**Figure 18: Standard ECM furnace and multi-stage HP**

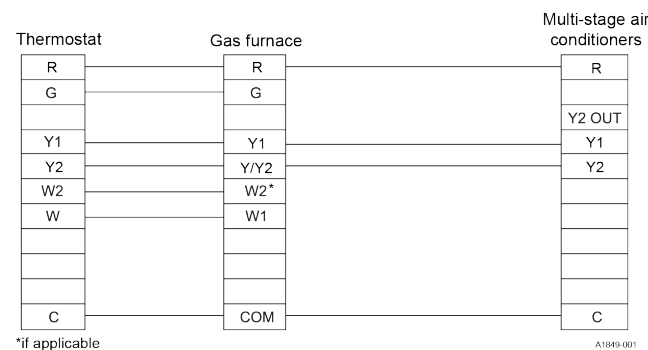


**Figure 19: Standard ECM furnace and single-stage AC**



\*if applicable

**Figure 20: Standard ECM furnace and premium multi-stage AC**



\*if applicable

## Accessory connections

The furnace control allows power-switching control of various accessories.

## Electronic air cleaner connection

Two 1/4 in. (6.4 mm) spade terminals (EAC and EAC-N) for electronic air cleaner connections are located on the control board. The terminals provide 115 VAC (1 A maximum) during circulating blower operation.

## Humidifier connection

Two 1/4 in. (6.4 mm) spade terminals for humidifier connections, HUM and HUM N, are located on the control board. The terminals provide 115 VAC (1 A maximum) during heating system operation.

## Twinning and staging

In applications where more heating capacity or more airflow capacity is needed than what one furnace can deliver, twinning can be used to make two furnaces operate in tandem (as long as the two furnaces have the same model number). Both furnaces must have separate power circuits but the circuits **must** be from the same phase or leg of power.

When two identical furnaces are installed using the same duct system, it is very important that the two furnace circulating air blowers operate simultaneously at all times. If one blower starts before the second blower, the duct system becomes pressurized and the blower on the second furnace may turn backwards, causing the second furnace to overheat and resulting in damage to the furnace. Twinning is used to make two furnaces operate in tandem, using one duct system and one room thermostat and causing both furnaces blowers to turn on and off simultaneously.

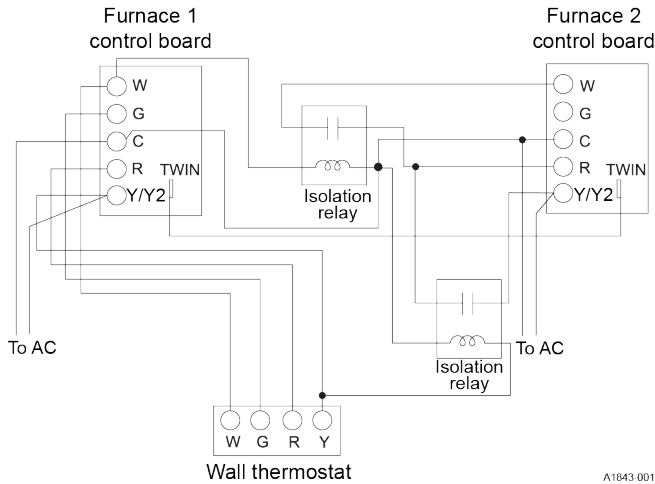
When furnaces use the twinning capability, the two controls do not trade on and off during a W1 call. Only the control that is connected to the thermostat conditions while both blowers continue to operate at the same time and speed.

## Furnace control twinning wiring

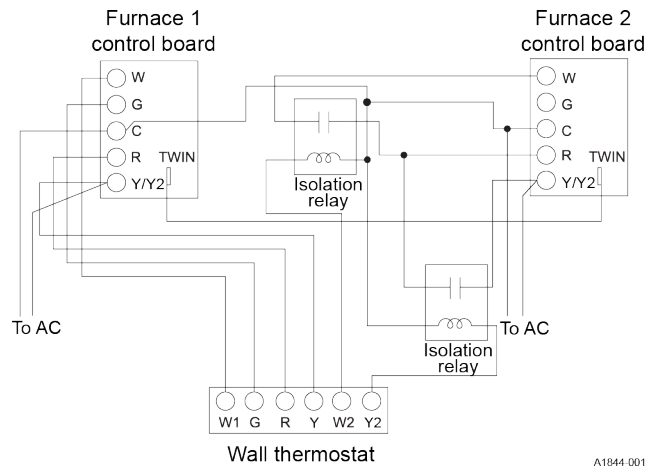
### CAUTION

Twinned furnaces must be on the same power source or line leg (phase). Notify the job electrician early so they can correctly balance the electrical load. Failure to do this may result in control voltage polarity issues. See the Rapid Red Flash fault code in [Furnace control diagnostics](#).

**Figure 21: Wiring using a single-stage thermostat**



**Figure 22: Wiring using a multi-stage thermostat**



## Twining duct system

Twinned furnaces must only be applied on a common duct system. A single air supply plenum must be used for both furnaces and indoor coils. Separate plenums and supply ducts systems cannot be utilized. A single return air plenum, common to both furnaces, must be used. It is suggested that a return platform be utilized, with bottom air entrance into each furnace.

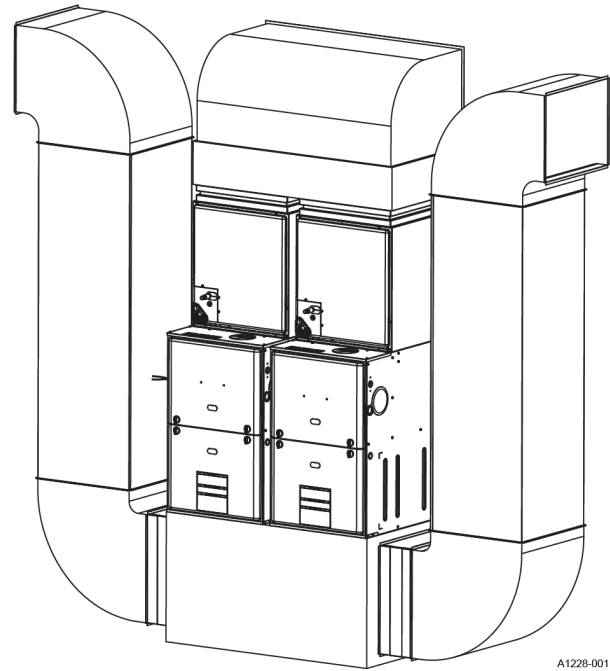
If a side entrance return system is used, the common return duct must be divided equally so as to supply each furnace with an equal amount of return air.

Both furnaces must be identical models in both heating capacity and CFM capacity. Both furnaces must be operated on the same motor speed taps. See Figure 23 for a typical application.

If furnace staging is required with two single stage furnaces on a common duct, where the gas burner on the first furnace operates on W1 and the gas burner on the second furnace operates on W2, it is best practice to use an air-mixing device in the plenum to mix the air from both furnaces. The mixing device must be installed before any ducts that supply air to occupied spaces. Twining causes both indoor fans to operate simultaneously. If a

mixing device is not used, any ducts that are connected downstream from the furnace that is not operating in heat mode supply cold air to the occupied spaces.

**Figure 23: Twinned furnaces**



## CAUTION

If a return duct is connected to only one furnace (with a connection between the two furnaces) an imbalance in the airflow will occur and the furnace furthest from the return plenum will overheat.

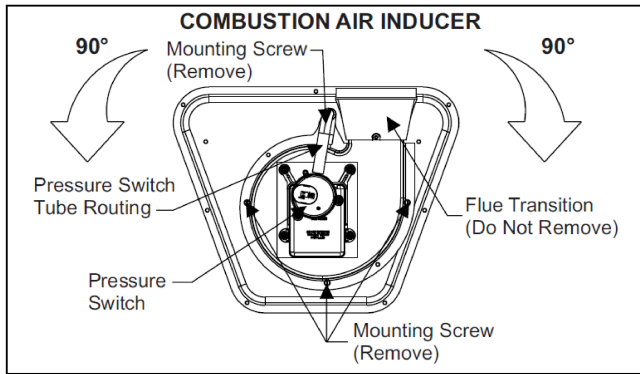
## Vent system

### Vent connections

All models are provided with a flue transition that is sized for 4 in. diameter vent connections. If a larger size vent connector is required, that connection must be installed external to the furnace. Figure 24 shows the furnace as it is shipped from the factory. To convert to a horizontal or downflow position, remove the four screws that secure the inducer assembly and rotate 90°, being careful not to damage the gasket. Reinstall screws. Remove cap from appropriate vent outlet location on the cabinet, cut insulation in cabinet to same size as the hole provided, and reinstall cap in the hole in the top panel.

- **Important:** In downflow applications, do not block the combustion air inlet. The furnace must be installed on a coil cabinet or subbase to allow combustion air to enter the burner compartment.

**Figure 24: Combustion air inducer**



### Category 1 - 450°F maximum vent temperature

Install the venting system in accordance with Section 5.3, Air for Combustion and Ventilation, of the National Fuel Gas Code Z223.1/NFPA 54 (latest edition), or Sections 7.2, 7.3 or 7.4 of CSA B149.1, National Gas and Propane Codes (latest edition) or applicable provisions of the local building code and these instructions.

Connect the furnace to any type of B, BW, or L vent connector and to a factory-built or masonry chimney. **Do not connect the furnace to a chimney flue serving a separate appliance designed to burn solid fuel.**

Install the appliance in a location where the space temperature is 32°F (0°C) or higher. If installing the appliance in a location where the ambient temperature is below 32°F (0°C), the combustion byproducts could condense, causing damage to the appliance heat exchanger.

This appliance may be common-vented with another gas appliance for residential installations as allowed by the codes and standards listed in this manual.

Non-HUD approved modular homes must be vented with an approved roof jack and may not be common-vented with other appliances.

### Venting

Category I venting consists of vertically venting one or more appliances in a B-vent or masonry chimney (as allowed), using single wall metal pipe or B-vent connectors. A Type B-vent system extends in a general vertical direction and does not contain offsets exceeding 45°. A vent system that does not have more than one 60° offset is permitted.

### Venting into an existing chimney

For Category I installations, the furnace is connected to a factory-built chimney or vent complying with a recognized standard, or a masonry or concrete chimney lined with a material acceptable to the authority having jurisdiction.

► **Important:** Do not vent this furnace into an unlined masonry chimney or concrete chimney.

Where use of an existing chimney is unavoidable, you must adhere to the following rules:

- The masonry chimney must be built and installed in accordance with nationally recognized building codes or standards and must be lined with approved fire-clay tile flue-liners or other approved liner material that resists corrosion, softening, or cracking from flue gases.
  - **Important:** Do not vent this furnace into an unlined masonry chimney.
- Only vent this furnace into a fire-clay tile-lined masonry chimney if a source of dilution air is available, such as by common venting with a draft hood equipped water heater. If no source of dilution air is available, you must use a Type B vent or masonry chimney vent kit S1-1CK0604. Refer to the instructions with the kit to correctly apply these masonry chimney kits.
- The chimney must extend at least 3 ft (0.91 m) above the highest point where it passes through a roof of a building and at least 2 ft (0.61 m) higher than any portion of the building with a horizontal distance of 10 ft (3.05 m).
- The chimney must extend at least 5 ft (1.52 m) above the highest equipment draft hood or flue collar.

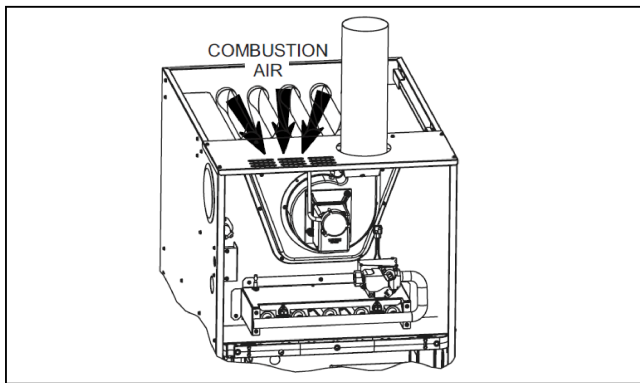
### Fan-assisted combustion system

This appliance is equipped with an integral mechanical means to draw products of combustion through the heat exchanger.

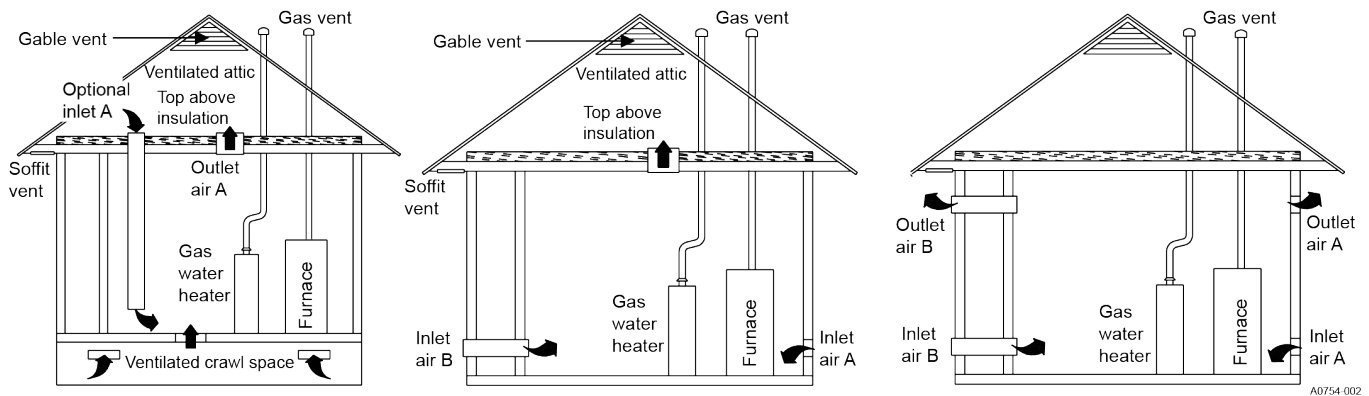
### Ambient combustion air supply

This type of installation will draw the air required for combustion from within the space surrounding the appliance and from areas or rooms adjacent to the space surrounding the appliance. This may be from within the space in a non-confined location or it may be brought into the furnace area from outdoors through permanent openings or ducts. A single, correctly sized pipe from the furnace vent connector to the outdoors must be provided. Combustion air is brought into the furnace through the unit top panel opening.

**Figure 25: Combustion airflow path through the furnace casing to the burner compartment**



**Figure 26: Combustion airflow path through the furnace casing to the burner compartment**



A0754-002

**WARNING**

This type of installation requires that the supply air to the appliance(s) be of a sufficient amount to support all of the appliance(s) in the area. Operation of a mechanical exhaust, such as an exhaust fan, kitchen ventilation system, clothes dryer or fireplace may create conditions requiring special attention to avoid unsatisfactory operation of gas appliances. A venting problem or a lack of supply air will result in a hazardous condition, which can cause the appliance to soot and generate dangerous levels of CARBON MONOXIDE, which can lead to serious injury, property damage and / or death.

**WARNING**

Examine the heat exchanger, vent pipe, combustion air passages, vent connectors, and chimney to be sure they are clear and free of obstructions.

**Note:** Proper orientation on the heat exchanger is for the compressed heat transfer blade portion to be up and away from the burner section, towards the air leaving end of the furnace.

An **unconfined space** is not less than 50 ft<sup>3</sup> (1.42 m<sup>3</sup>) per 1,000 Btu/h (0.2928 kW) input rating for all of the appliances installed in that area.

Rooms communicating directly with the space containing the appliances are considered part of the unconfined space, if doors are furnished with openings or louvers.

A **confined space** is an area with less than 50 ft<sup>3</sup> (1.42 m<sup>3</sup>) per 1,000 Btu/h (0.2928 kW) input rating for all of the appliances installed in that area. The following must be considered to obtain proper air for combustion and ventilation in confined spaces.



## Dampers, louvers and grilles (Canada only)

The blocking effects of louvers, grilles and screens must be given consideration in calculating free area. If the free area of a specific louver or grille is not known, see Table 6, to estimate free area.


**Table 6: Estimated free area**

Wood or metal Louvers or grilles	Wood 20-25% <sup>1</sup> Metal 60-70% <sup>1</sup>
Screens <sup>2</sup>	1/4 in. (6.4 mm) mesh or larger 100%

**Note:**

- Do not use less than 1/4 in. (6.4 mm) mesh.
- The free area of louvers and grille varies widely; the installer must follow louver or grille manufacturer's instructions.

- Calculate the free area of a supply air opening by subtracting the blockage area of all fixed louvers grilles or screens from the gross area of the opening.
- Apertures in a fixed louver, a grille, or screen have no dimension smaller than 1/4 in. (0.64 cm).
- Manually operated dampers or manually adjustable louvers are not permitted for use.
- Automatically operated dampers or automatically adjustable louvers are interlocked so that the main burner cannot operate unless either the damper or the louver is in the fully open position.


**WARNING**

Always verify that any pre-existing venting system previously attached to a different Category I furnace is still properly sized for safe use of this furnace.

An improperly sized vent system can cause CARBON MONOXIDE to spill into the living space causing personal injury and/or death.

**Table 7: Unconfined space minimum area**

Btu/h input rating	Minimum free area required for each opening
40,000	40 in. <sup>2</sup> (258 cm <sup>2</sup> )
60,000	60 in. <sup>2</sup> (387 cm <sup>2</sup> )
80,000	80 in. <sup>2</sup> (516 cm <sup>2</sup> )
100,000	100 in. <sup>2</sup> (645 cm <sup>2</sup> )
120,000	120 in. <sup>2</sup> (742 cm <sup>2</sup> )
130,000	130 in. <sup>2</sup> (838 cm <sup>2</sup> )

**Table 8: Free area**

Btu/h input rating	Minimum free area required for each opening		
	Horizontal duct (2,000 Btu/h)	Vertical duct or opening to outside (4,000 Btu/h)	Round duct (4,000 Btu/h)
40,000	20 in. <sup>2</sup> (129 cm <sup>2</sup> )	10 in. <sup>2</sup> (64 cm <sup>2</sup> )	4 in. (10 cm)
60,000	30 in. <sup>2</sup> (193 cm <sup>2</sup> )	15 in. <sup>2</sup> (97 cm <sup>2</sup> )	5 in. (13 cm)
80,000	40 in. <sup>2</sup> (258 cm <sup>2</sup> )	20 in. <sup>2</sup> (129 cm <sup>2</sup> )	5 in. (13 cm)
100,000	50 in. <sup>2</sup> (322 cm <sup>2</sup> )	25 in. <sup>2</sup> (161 cm <sup>2</sup> )	6 in. (15 cm)
120,000	60 in. <sup>2</sup> (387 cm <sup>2</sup> )	30 in. <sup>2</sup> (193 cm <sup>2</sup> )	7 in. (18 cm)
130,000	65 in. <sup>2</sup> (419 cm <sup>2</sup> )	33 in. <sup>2</sup> (213 cm <sup>2</sup> )	7 in. (18 cm)

Example: Determining free area.

Appliance 1 Appliance 2 Total input  
 100,000 + 30,000 = (130,000 ÷ 4,000) = 32.5 in.<sup>2</sup> vertical

Appliance 1 Appliance 2 Total input  
 100,000 + 30,000 = (130,000 ÷ 2,000) = 65 in.<sup>2</sup> horizontal

## Air supply openings and ducts

- An opening may be used in lieu of a duct to provide to provide the outside air supply to an appliance unless otherwise permitted by the authority having jurisdiction. The opening must be located within 12 in. (30.5 cm) horizontally from the burner level of the appliance. See [Combustion air source from outdoors](#) and for additional information and the safety check procedure.
- The duct must be either metal or a material meeting the class 1 requirements of CAN4-S110 Standard for Air Ducts.
- The duct must be at least the same cross-sectional area as the free area of the air supply inlet opening to which it connects.
- The duct must terminate within 12 in. (30.5 cm) above and within 24 in. (61 cm) horizontally from the burner level of the appliance having the largest input.
- Only use a square or rectangular-shaped duct when the required free area of the supply opening is 9 in.<sup>2</sup> (58.06 cm<sup>2</sup>) or larger. When using a square or rectangular duct, its small dimension must not be less than 3 in. (7.6 cm).
- An air inlet supply from outdoors must be equipped with a means to prevent the direct entry of rain and wind that does not reduce the required free area of the air supply opening.
- Locate an air supply inlet opening from the outdoors not less than 12 in. (30.5 cm) above the outside grade level.

## Combustion air source from outdoors

1. Two permanent openings, one within 12 in. (30.5 cm) of the top and one within 12 in. (30.5 cm) of bottom of the confined space, must communicate directly or by means of ducts with the outdoors, crawl spaces, or attic spaces.
2. One permanent opening, starting within 12 in. (30.5 cm) of the top of the enclosure is permitted where the equipment has clearances of at least 1 in. (2.54 cm) from the sides and back and 6 in. (15.2 cm) from the front of the appliance. The opening must communicate directly with the outdoors and have a minimum free area of:
  - 1 in<sup>2</sup>/3,000 Btu/h (700 mm<sup>2</sup>/kW) of the total input rating of all equipment located in the enclosure
  - Not less than the sum of all vent connectors in the confined space
3. The duct must be least the same cross-sectional area as the free area of the air supply inlet opening to which it connects.
4. The blocking effects of louvers, grilles, and screens must be given consideration in calculating free area. If the free area of a specific louver or grille is not known, see Table 6.

## Ventilated combustion air

The ventilated attic space or a crawl space from which the combustion air is taken must comply with the requirements specified in [Combustion air source from outdoors](#) in this manual or in Section 5.3, Air for Combustion and Ventilation of the National Fuel Gas Code, ANSI Z223.1 (latest edition). This type of installation requires two correctly sized pipes. One brings combustion air from an adequately ventilated attic space or crawl space and the second pipe extends from the furnace vent connection (top right of the unit) to the exterior of the building.

## Vent and supply (outside) air safety check procedure

For Category I furnaces, vent installations are in accordance with Parts 7 and 11 of the National Fuel Gas Code, ANSI Z223.1/NFPA 54, and Section 7 and Appendix B of the CSA B149.1, Natural Gas and Propane Installation Codes, the local building codes, furnace and vent manufactures instructions.

Multi-story or common venting systems are permitted and must be installed in accordance with the National Fuel Gas Code, ANSI Z223.1/ NFPA 54 and the CSA B149.1, Natural Gas and Propane Installation Codes, local codes, and the manufactures instructions.

Vent connectors serving Category I furnaces are not connected into any portion of mechanical draft systems operating under positive pressure.

Horizontal portions of the venting system a supported to prevent sagging using hangers or perforated straps and must slope upwards not less than 1/4 in./ft (20.8 mm/m) from the furnace to the vent terminal.

It is recommended that you follow the venting safety procedure below.

This procedure is designed to detect an inadequate ventilation system that can cause the appliances in the area to operate improperly causing unsafe levels of carbon monoxide or an unsafe condition to occur.



## WARNING

### CARBON MONOXIDE POISONING HAZARD

Failure to follow the steps outlined below for each appliance connected to the venting system being placed into operation could result in carbon monoxide poisoning or death.

The following steps shall be followed for each appliance connected to the venting system being placed into operation, while all other appliances connected to the venting system are not in operation:

1. Inspect the venting system for proper size and horizontal pitch. Determine that there is no blockage, restriction, leakage, corrosion or other deficiencies, which could cause an unsafe condition
2. Close all building doors and windows.
3. Turn on clothes dryers and TURN ON any exhaust fans, such as range hoods and bathroom exhausts, so they shall operate at maximum speed. Open the fireplace dampers. Do not operate a summer exhaust fan.
4. Follow the lighting instructions. Place the appliance being inspected in operation. Adjust thermostat so the appliance shall operate continuously.
5. Test each appliance (such as a water heater) equipped with a draft hood for spillage (down-draft or no draft) at the draft hood relief opening after 5 minutes of main burner operation. Appliances that do not have draft hoods need to be checked at the vent pipe as close to the appliance as possible. Use a combustion analyzer to check the CO<sub>2</sub> and CO levels of each appliance. Use a draft gauge to check for a downdraft or inadequate draft condition.
6. After it has been determined that each appliance properly vents when tested as outlined above, return doors, windows, exhaust fans, fireplace dampers and any other gas burning appliance to their normal condition.
7. If improper venting is observed during any of the above tests, a problem exists with either the venting system or the appliance does not have enough combustion air (Supply Air from outside) to complete combustion. This condition must be corrected before the appliance can function safely.  

Note: An unsafe condition exists when the CO reading exceeds 40 ppm and the draft reading is not in excess of -0.1 in. W.C. (-25 kPa) with all of the appliance(s) operating at the same time.
8. Any corrections to the venting system and/or to the supply (outside) air system must be in accordance with the National Fuel Gas Code Z223.1 or CAN/CGA B149.1 Natural Gas and Propane Installation Code (latest editions). If the vent system must be resized, follow the appropriate tables in Appendix G of the above codes or for this appliance.

## Start-up and adjustments

The furnace installer **must** perform the following start-up checks on every new furnace installation:

- Gas piping leak check
- Furnace input rate check
- Air temperature rise check

See the instructions on how to perform each of these required installation checks in the sections that follow.

► **Important:** You must check all electrical connections made in the field and in the factory for adequate tightness.

When the gas supply is initially connected to the furnace, the gas piping may be full of air. In order to purge this air, loosen the ground union until you detect the odor of gas. When gas is detected, immediately retighten the ground union and check for leaks. Allow 5 min for any gas to dissipate before continuing with the start-up procedure. Ensure adequate ventilation is available to dilute and carry away any vented gas.

## Removing NO<sub>x</sub> screens (Lo-NO<sub>x</sub> models only)

### NOTICE

When using the furnace with LP(propane) gas and it is equipped with NO<sub>x</sub> screens, you must remove the screens before start-up.

1. Make sure that the electrical power to the unit is turned off and that the gas supply is turned off at the shut-off valve.
2. Remove the burner compartment access door.
3. Disconnect the gas supply piping at the union to permit removal of the entire burner and gas control assembly from the vestibule panel. Use the wrench boss on the gas valve when removing or installing the piping.
4. Unplug the igniter from the wire harness. Disconnect the flame sensor wires located on top of the air shield. Unplug the gas valve from the wiring harness.
5. Remove the screws holding the burner assembly to the vestibule panel.
6. Remove the burner assembly. It should be possible to swing the burner assembly out of the way without disconnecting the remaining wires.
7. With the burner assembly out of the way, slide the NO<sub>x</sub> screens out of the heat exchanger tubes and discard the screens.
8. Replace all components in reverse order. Reconnect all wiring.

## Gas piping leak check

- **Important:** Burner ignition may not be satisfactory on first start-up due to residual air in the gas line or until gas manifold pressure is adjusted. The ignition control makes three attempts to light before locking out.

With the furnace in operation, check all of the pipe joints, gas valve connections and manual valve connections for leakage using an approved gas detector, a non-corrosive leak detection fluid or other leak detection methods. Take appropriate action to stop any leak. If a leak persists, replace the faulty component.

The furnace and its equipment shut-off valve must be disconnected from the gas supply during any pressure testing of that system at test pressures in excess of 1/2 in. psig (3.45 kPa).

The furnace must be isolated from the gas supply piping system by closing the equipment shut-off valve during any pressure testing of the gas supply system.

## Ignition system sequence

1. Turn the gas supply on at the external valve and main gas valve.
2. Set the thermostat above room temperature to call for heat.
3. System start-up occurs as follows:
  - a. The induced draft blower motor starts and comes up to speed. Shortly after inducer start-up, the hot surface igniter glows for about 17 s.
  - b. After this warm up, the ignition module energizes (opens) the main gas valve.
  - c. Approximately 30 s after a flame is established, the supply air blower starts.

- **Important:** Burner ignition may not be satisfactory on first startup due to residual air in the gas line or until gas manifold pressure is adjusted. The ignition control makes three attempts to light before locking out.

- **Important:** With the furnace in operation, check all of the pipe joints, gas valve connections and manual valve connections for leakage using an approved gas detector, a non-corrosive leak detection fluid, or other leak detection methods. Take appropriate steps to stop any leak. If a leak persists, replace the component.

## Calculating the furnace input (natural gas)

### NOTICE

Burner orifices are sized to provide the correct input rate using natural gas with a heating value of 1,030 Btu/cu ft (38.4 MJ/m<sup>3</sup>). If the heating value of your gas is significantly different, it may be necessary to replace the orifices.

### NOTICE

**Do not** set manifold pressure less than 3.2 in. W.C. or more than 3.8 in. W.C. for natural gas at sea level. If manifold pressure is outside this range, change main burner orifices.

### NOTICE

If orifice hole appears damaged or it is suspected to have been redrilled, check orifice hole with a numbered drill bit of correct size. Never redrill an orifice. A burr-free and squarely aligned orifice hole is essential for proper flame characteristics.

### CAUTION


**Do not** bottom out gas valve regulator adjusting screw. This can result in unregulated manifold pressure and result in excess overfire and heat exchanger failures.

Verify natural gas input rate by clocking the meter as follows:

1. Turn off all other gas appliances and pilots.
2. Run the furnace for a minimum of 3 min in heating operation.
3. Measure time (in seconds) for the gas meter to complete one revolution and note the reading. The 2 cu ft dial provides a more accurate measurement of gas flow.
4. See Table 9 for cubic feet of gas per hour.
5. Multiply cubic feet per hour by heating value (Btu/cu ft) to obtain input.

If the clocked rate does not match the input rate from the unit nameplate, follow the steps in [Adjusting the manifold gas pressure and input rate](#).

Repeat Step 2 to Step 5 until the correct input is achieved.

 <b>CAUTION</b>
<p>Ensure to relight any gas appliances that were turned off at the start of this input check.</p>

**Table 9: Gas rate (cu ft/h) at full input**

Time for one revolution s	Size of Test Dial			Time for one revolution s	Size of Test Dial		
	1 cu ft	2 cu ft	5 cu ft		1 cu ft	2 cu ft	5 cu ft
10	360	720	1800	50	72	144	360
11	327	655	1636	51	71	141	355
12	300	600	1500	52	69	138	346
13	277	555	1385	53	68	136	340
14	257	514	1286	54	67	133	333
15	240	480	1200	55	65	131	327
16	225	450	1125	56	64	129	321
17	212	424	1059	57	63	126	316
18	200	400	1000	58	62	124	310
19	189	379	947	59	61	122	305
20	180	360	900	60	60	120	300
21	171	343	857	62	58	116	290
22	164	327	818	64	56	112	281
23	157	313	783	66	54	109	273
24	150	300	750	68	53	106	265
25	144	288	720	70	51	103	257
26	138	277	692	72	50	100	250
27	133	267	667	74	48	97	243
28	129	257	643	76	47	95	237
29	124	248	621	78	46	92	231
30	120	240	600	80	45	90	225
31	116	232	581	82	44	88	220
32	113	225	563	84	43	86	214
33	109	218	545	86	42	84	209
34	106	212	529	88	41	82	205
35	103	206	514	90	40	80	200
36	100	200	500	92	39	78	196
37	97	195	486	94	38	76	192
38	95	189	474	96	38	75	188
39	92	185	462	98	37	74	184
40	90	180	450	100	36	72	180
41	88	176	439	102	35	71	178
42	86	172	429	104	35	69	173

**Table 9: Gas rate (cu ft/h) at full input**

Time for one revolution	Size of Test Dial			Time for one revolution	Size of Test Dial		
	1 cu ft	2 cu ft	5 cu ft		1 cu ft	2 cu ft	5 cu ft
s				s			
43	84	167	419	106	34	68	170
44	82	164	409	108	33	67	167
45	80	160	400	110	33	65	164
46	78	157	391	112	32	64	161
47	76	153	383	116	31	62	155
48	75	150	375	120	30	60	150
49	73	147	367	—	—	—	—

### Adjusting the manifold gas pressure and input rate

It is possible to measure the inlet and the manifold gas pressure by connecting the U tube manometer to the gas valve with a piece of tubing. See Figure 27 for the locations of the pressure ports on the gas valve.

Before you begin:

1. Turn the gas off at the ball valve or gas cock on the gas supply line before the gas valve.
2. Find the pressure ports on the gas valve marked Out P and In P.
3. Using a 3/32 in. (2.4 mm) hex head wrench, loosen the set screw by turning it one turn counterclockwise. **Do not remove the set screw from the pressure port.**
4. Follow the steps in [Reading the inlet gas pressure](#) or [Reading the manifold gas pressure](#), as appropriate.

### Reading the inlet gas pressure

1. Connect the positive side of the manometer to the IN P Tap on the gas valve. Do not connect any tubing to the negative side of the manometer, as it references atmospheric pressure. See Figure 28 for connection details.
2. Turn gas and electrical supplies on and follow the operating instructions to place the unit back in operation.

**Table 10: Inlet gas pressure range**

	Natural gas	Propane (LP)
Minimum	4.5 in. W.C. (1.12 kPa)	8.0 in. W.C. (1.99 kPa)
Maximum	10.5 in. W.C. (2.61 kPa)	13.0 in. W.C. (3.24 kPa)

► **Important:** The inlet gas pressure operating range table specifies what the minimum and maximum gas line pressures must be for the furnace to operate safely. The gas line pressure must be a minimum of:

- 7 in. W.C. (1.74 kPa) for natural gas
  - 11 in. W.C. (2.74 kPa) for propane (LP) gas
- This is in order to obtain the Btu input specified on the rating plate or the nominal manifold pressure specified in these instructions and on the rating plate.

3. Once the correct gas inlet pressure has been established, see Table 10, turn the gas valve to OFF and turn the electrical supply switch to OFF. Then, remove the flexible tubing from the gas valve pressure tap and tighten the pressure tap plug using the 3/32 in. (2.4 mm) hex head wrench.
4. Turn the electrical and gas supplies back on, and with the burners in operation, check for gas leakage around the gas valve pressure port for leakage using an approved non-corrosive gas leak detection fluid, or other non-flammable leak detection methods.

### Reading the manifold gas pressure

1. Connect the positive side of the manometer to the adapter previously installed in the OUT P Tap on the gas valve. Do not connect any tubing to the negative side of the manometer, as it will reference atmospheric pressure. See Figure 28 for connection details.

► **Important:** The cap for the pressure regulator must be removed entirely to gain access to the adjustment screw. Loosening or tightening the cap does not adjust the flow of gas.

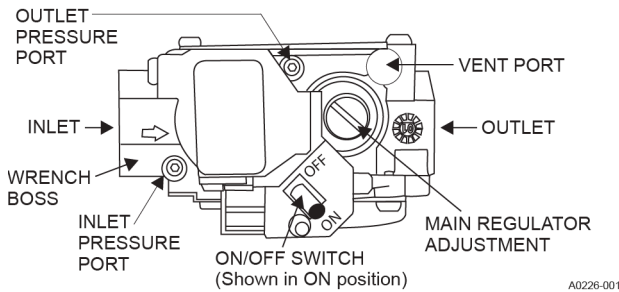
2. See Figure 27 for location of pressure regulator adjustment cap and adjustment screws on main gas valve.
3. Turn on the gas and electrical supplies and follow the operating instructions to place the unit back in operation.

- Adjust manifold pressure by adjusting gas valve regulator screw for the appropriate gas per the following.

**Table 11: Nominal manifold pressure**

Natural gas	3.5 in. W.C. (0.87 kPa)
Propane (LP) gas	10.0 in. W.C. (2.488 kPa)

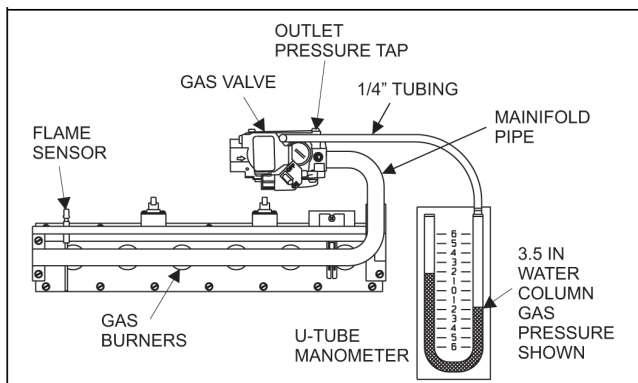
**Figure 27: Gas valve**



➤ **Important:** If gas valve regulator is turned in (clockwise), manifold pressure is increased. If screw is turned out (counter clockwise), manifold pressure will decrease.

- After the manifold pressure has been adjusted, recalculate the furnace input to make sure you have not exceeded the specified input on the rating plate. See [Calculating the furnace input \(natural gas\)](#).
- Once the correct BTU (kW) input has been established, turn the gas valve to OFF and turn the electrical supply switch to OFF; then remove the flexible tubing from the gas valve pressure tap and tighten the pressure tap plug using the 3/32 in. (2.4 mm) hex head wrench.
- Turn the electrical and gas supplies back on, and with the burners in operation, check for gas leakage around the gas valve pressure port using an approved non-corrosive gas leak detection fluid, or other non-flammable leak detection methods.

**Figure 28: Reading gas pressure**



## Airflow settings

### Cooling airflow settings

This unit is equipped with a five-speed blower motor. Select the required cooling airflow by connecting the required motor speed tap wire to the HI COOL terminal on the control board. Select the speed to deliver approximately 350 CFM to 400 CFM per ton of AC cooling capacity. Use of airflow outside of this range may result in diminished air conditioning performance and may result in lower overall energy efficiency and higher electric utility bills. See Table 12 for default cooling blower settings.

### Continuous fan airflow default settings

The default blower speed for continuous fan operation is LOW speed. The continuous fan speed is set at the factory to the default continuous fan blower speed.

The default position is with the LOW speed motor wire on the G terminal. In certain circumstances, it may be necessary to move the continuous fan speed to a different speed. However, doing so results in higher than normal electrical energy usage and electric utility bills.

**Table 12: Default blower speeds**

Model number	Default blower speeds		
	Heat	Cool	Continuous fan
040A12	Low (1)	High (5)	Medium low (2)
060A12	Medium low (2)	High (5)	Low (1)
080B12	Medium (3)	High (5)	Low (1)
080C16	Medium (3)	High (5)	Low (1)
080C20	Medium (3)	High (5)	Low (1)
100B12	Medium (3)	High (5)	Low (1)
100C16	Medium low (2)	High (5)	Low (1)
100C20	Medium (3)	High (5)	Low (1)
120C16	Medium low (2)	High (5)	Low (1)
120C20	High (5)	Medium high (4)	Low (1)
130D20	High (5)	Medium high (4)	Low (1)

### Gas heating airflow default setting

This unit is equipped with a five-speed blower motor. The heating blower speed is set at the factory to the default blower speed, which is the blower speed that delivers the correct airflow for proper heating operation in most applications. The default heating blower speed for each model is shown in Table 12. Use of a heating speed other than the default heating blower speed may result in reduced energy efficiency and higher electric utility bills.

In certain circumstances, it may be necessary to move the heating blower speed to a different motor speed tap. **Not all five motor speeds are appropriate for gas heating operation.** The use of heating airflow on a speed other than the default speed results in diminished heating performance and may cause the furnace temperature limit controls to shut down the furnace.

## Measurement of temperature rise

### WARNING

The temperature rise, or temperature difference between the return air and the supply (heated) air from the furnace, must be within the range shown on the furnace rating plate and within the application limitations for specific furnace ratings and physical/electrical data as specified in these instructions. The supply air temperature cannot exceed the "Maximum Supply Air Temperature" as it may cause premature heat exchanger failure, high levels of Carbon Monoxide, a fire hazard, personal injury, property damage, and/or death.

After about 5 min of operation, determine the furnace temperature rise. Measure the temperature of both the return air and the heated air in the ducts, about 6 ft (1.83 m) from the furnace where they are not affected by radiant heat. Increase the blower speed to decrease the temperature rise. Decrease the blower speed to increase the temperature rise.

The blower speed taps are located on the furnace control board in the blower compartment. See Figure 29 and the unit wiring label to change the blower speed. To use the same speed tap for heating and cooling, the heat terminal and cool terminal must be connected using a jumper wire and connected to the required motor lead. Place all unused motor leads on park terminals. One park terminal is provided.

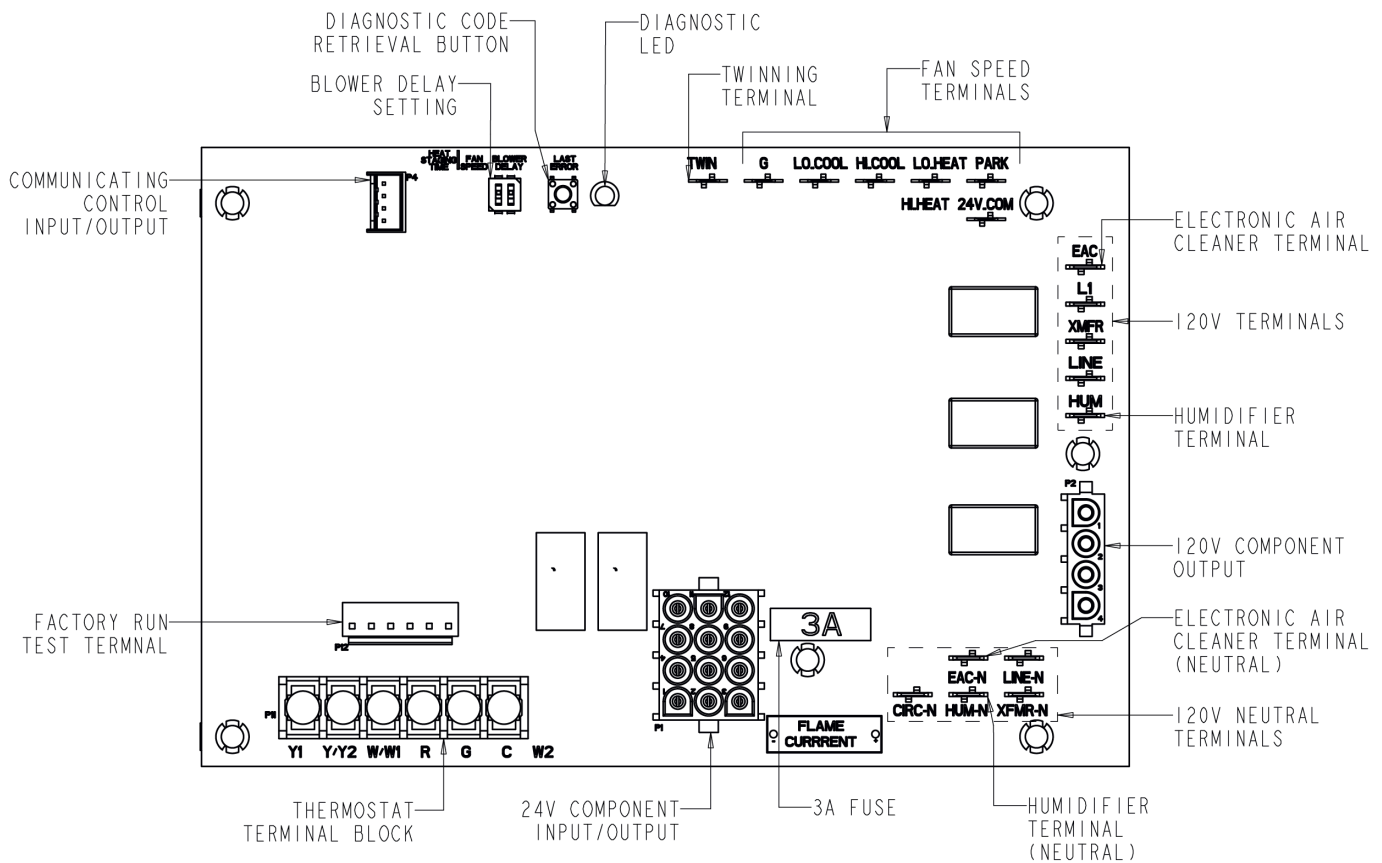
### Adjustment of blower control settings

This furnace is equipped with a time-on/time-off heating blower control. The blower-on delay is fixed at 30 s. The blower-off delay has four settings (60 s, 90 s, 120 s, and 180 s). The blower-off delay is factory-set to 120 s. The blower-off setting must be long enough to adequately cool the furnace, but not so long that cold air is blown into the heated space. The blower-off timing can be adjusted by positioning the dip switches as shown in Table 13. See Figure 29 for the dip switch location on the control board.

**Table 13: Dip switch settings for blower-off timing**

Dip switch setting	Blower-off delay (s)
00	60
01	90
10	120
11	180

**Figure 29: Furnace control board**



A1761-001



**Table 14: Blower performance CFM - any position (without filter)**

Model	Speed	Airflow data (SCFM) external static pressure (in. W.C.)							
		0.1	0.2	0.3	0.4	0.5	0.6	0.7	0.8
040A12	High	1375	1350	1325	1300	1275	1225	1200	1175
	Medium High	1225	1200	1150	1125	1100	1075	1025	1000
	Medium	1150	1100	1075	1050	1000	975	925	900
	Medium Low	1050	1025	1000	950	900	875	825	775
	Low	925	900	850	825	775	725	675	625
060A12	High	1375	1325	1300	1275	1225	1200	1175	1125
	Medium High	1125	1075	1050	1025	975	950	900	850
	Medium	1025	975	950	900	850	825	775	725
	Medium Low	925	875	850	800	750	725	675	625
	Low	850	825	775	725	675	625	575	525
080B12	High	1425	1400	1375	1325	1300	1275	1225	1200
	Medium High	1325	1275	1250	1225	1175	1150	1100	1075
	Medium	1175	1125	1075	1050	1000	975	925	900
	Medium Low	1050	1000	975	925	900	850	800	775
	Low	925	875	825	800	750	700	650	600
080C16	High	1750	1700	1675	1625	1575	1550	1500	1475
	Medium High	1625	1600	1550	1500	1475	1425	1375	1325
	Medium	1400	1375	1325	1275	1225	1200	1125	1100
	Medium Low	1275	1225	1175	1125	1100	1050	1000	950
	Low	1150	1100	1050	1000	950	900	850	775
080C20	High	2025	1950	1900	1850	1800	1750	1700	1650
	Medium High	1825	1750	1700	1625	1600	1525	1475	1425
	Medium	1675	1625	1550	1500	1450	1400	1325	1275
	Medium Low	1475	1400	1325	1275	1225	1150	1075	1025
	Low	1200	1100	1025	950	875	800	725	650
100B12	High	1550	1500	1475	1425	1400	1375	1325	1300
	Medium High	1400	1350	1300	1275	1250	1200	1175	1125
	Medium	1225	1175	1150	1100	1075	1025	1000	950
	Medium Low	1025	975	950	900	850	825	775	750
	Low	900	850	800	775	725	675	650	600
100C16	High	1900	1850	1825	1800	1750	1725	1675	1625
	Medium High	1700	1675	1625	1600	1550	1525	1475	1425
	Medium	1500	1450	1400	1375	1325	1300	1250	1225
	Medium Low	1250	1200	1175	1125	1075	1050	1000	950
	Low	1125	1050	1025	975	925	875	850	800
100C20	High	1975	1950	1900	1850	1825	1775	1725	1700
	Medium High	1825	1775	1725	1675	1650	1600	1550	1500
	Medium	1675	1600	1575	1500	1475	1425	1375	1325
	Medium Low	1475	1425	1375	1325	1275	1225	1150	1075
	Low	1275	1225	1150	1100	1025	950	825	750

**Table 14: Blower performance CFM - any position (without filter)**

Model	Speed	Airflow data (SCFM) external static pressure (in. W.C.)							
		0.1	0.2	0.3	0.4	0.5	0.6	0.7	0.8
120C16	High	2050	2025	1975	1950	1925	1900	1850	1800
	Medium High	1850	1800	1775	1750	1700	1675	1625	1600
	Medium	1700	1675	1650	1600	1550	1525	1475	1450
	Medium Low	1475	1425	1400	1350	1325	1275	1250	1200
	Low	1175	1125	1075	1025	1000	950	900	875
120C20	High	2000	1925	1875	1825	1775	1725	1675	1625
	Medium High	1850	1775	1725	1675	1600	1550	1500	1450
	Medium	1700	1625	1575	1500	1450	1400	1325	1275
	Medium Low	1475	1400	1350	1275	1225	1175	1100	1050
	Low	1250	1175	1100	1025	950	875	800	725
130D20	High	2100	2050	2000	1975	1925	1875	1850	1800
	Medium High	1925	1875	1825	1800	1775	1725	1675	1650
	Medium	1750	1725	1675	1625	1600	1550	1500	1475
	Medium Low	1625	1575	1525	1475	1425	1375	1325	1300
	Low	1325	1250	1200	1150	1075	1025	950	900

**Note:**

- Airflow is expressed in standard cubic feet per minute (SCFM).
- Motor voltage is at 115 V.
- Not all speeds are recommended for use as heating speeds.

## Safety controls

### Control circuit fuse

A 3 A fuse is provided on the control circuit board to protect the 24 V transformer from overload caused by control circuit wiring errors. This is an ATO 3 automotive-type fuse and is located on the control board.

### Blower door safety switch



Main power to the unit must still be interrupted at the main power disconnect switch before any service or repair work is to be done to the unit. **Do not rely upon the interlock switch as a main power disconnect.**

Blower and burner must never be operated without the blower panel in place.

This unit is equipped with an electrical interlock switch mounted in the blower compartment. This switch interrupts all power at the unit when the panel covering the blower compartment is removed.

Electrical supply to this unit is dependent upon the panel that covers the blower compartment being in place and correctly positioned.

### Rollout switch controls

These controls are mounted on the burner assembly. If the temperature in the area surrounding burner exceeds its set point, the gas valve is de-energized. The operation of this control indicates a malfunction in the combustion air blower, heat exchanger, or a blocked vent pipe connection. Corrective action is required. These are manual reset controls that must be reset before operation can continue.

### Pressure switches

This furnace is supplied with a pressure switch, which monitors the flow through the combustion air/vent piping and condensate drain system. This switch de-energizes the gas valve if any of the following conditions are present:

- Blockage of vent piping or terminal
- Failure of combustion air blower motor

## Limit controls

There is a high temperature limit control located on the furnace vestibule panel. This is an automatic reset control that provides over temperature protection due to reduced airflow. This may be caused by the following:

- A dirty filter
- Indoor fan motor failure
- Too many supply or return registers closed or blocked off
- Incorrectly sized duct system

The control module locks out if the limit trips five consecutive times. If this occurs, the control resets and tries ignition again after 1 h.

## Sequence of operation

The following describes the sequence of operation of the furnace. Refer to the User's Manual for component location.

### Continuous blower

Cooling or heating thermostats have a fan switch that has ON and AUTO positions. In the ON position, the thermostat circuit is completed between terminals R and G. The motor operates continuously on the speed that is selected on the G terminal on the main control board.

### Intermittent blower - cooling

On cooling/heating thermostats with a fan switch, when the fan switch is set in the auto position and the thermostat calls for cooling, a circuit is completed through the Y1 cool terminal and runs on the speed selected on the COOL tap of the control board. The fan-off setting is fixed at 60 s for SEER enhancement. The control board can accommodate two-stage cooling. When a two-stage cool thermostat is connected to the Y1 and Y2 terminals on the board, the blower operates on LOW COOL speed when Y1 is energized and on HI COOL speed when Y1 and Y2 are energized.

### Heating cycle

When the thermostat switch is set on HEAT and the fan is set on AUTO, and there is a call for heat, a circuit is completed between terminals R and W of the thermostat. When the correct amount of combustion air is being provided, the pressure switch closes and the ignition control provides a 17 s ignitor warm-up period. The gas valve then opens, the gas starts to flow, ignition occurs, and the flame sensor begins its sensing function. The blower motor energizes 30 s after the gas valve opens, if a flame is detected. Normal furnace operation continues until the thermostat circuit between R and W is opened, which causes the ignition system and gas valve to de-energize and the burner flames to be extinguished. The vent motor operates for 15 s and the blower motor operates for the amount of time set by the fan-off delay dip switch located on the control board. See Figure 29. The heating cycle is now complete and ready for the start of the next heating cycle.

If the flame is not detected within 7 s of the gas valve opening or if the flame is lost for 2 s during the 10 s stabilization period, the gas valve is shut off and a retry operation begins. During a retry operation, the vent motor starts a 15 s inter-purge and the ignitor warm-up time is extended to 27 s. If the flame is established for more than 10 s after ignition during a retry, the control clears the ignition attempt (retry) counter. If three retries occur during a call for heat, the furnace shuts down for 1 h. If at the end of the 1 h shut down there is a call for heat, the furnace initiates a normal start cycle. If the problem has not been corrected, the furnace locks out after three retries.

A momentary loss of gas supply, flame blowout, or a faulty flame probe circuit results in a disruption in the flame and is sensed within 1 s. The gas valve de-energizes and the control begins a recycle operation. A normal ignition sequence begins after a 15 s inter-purge. If during the five recycles the gas supply does not return, or the fault condition is not corrected, the ignition control locks out for 60 min.

During burner operation, a momentary loss of power for 50 ms or longer de-energizes the gas valve. When the power is restored, the gas valve remains de-energized and the ignition sequence immediately restarts.

## Hot surface ignition system



### WARNING

Do not attempt to light this furnace by hand (with a match or any other means). There may be a potential shock hazard from the components of the hot surface ignition system. The furnace can only be lit automatically by its hot surface ignition system.

## Troubleshooting

Make the following visual checks before troubleshooting:

1. Check to see that the power to the furnace and the ignition control module is on.
2. Check the manual shut-off valves in the gas line to the furnace are open.
3. Make sure all wiring connections are secure.
4. Review the sequence of operation. Start the system by setting the thermostat above the room temperature. Observe the system's response. Then use the troubleshooting section in this manual to check the system's operation.



## WARNING

Never bypass any safety control to allow furnace operation. To do so allows furnace to operate under potentially hazardous conditions.

Do not try to repair controls. Replace defective controls with UPG Source 1 Parts.

Never adjust pressure switch to allow furnace operation.

## Furnace control diagnostics

The furnace has built-in, self-diagnostic capability. A blinking LED light on the control board can flash red, green or amber to indicate various conditions. The control continuously monitors its own operation and the operation of the system. If a failure occurs, the LED light indicates the failure code.

The SLOW flash speed is 2 s on and 2 s off.

The other flash codes listed below have the following timing: LED light turns on for 1/3 s and off for 1/3 s. This pattern is repeated the number of times equal to the code. There is a 2 s pause between codes. For example, the six red flash code flashes the LED light on and off six times, then is off for 2 s. This pattern repeats as long as the fault condition remains.

**SLOW GREEN FLASH:** Normal operation, no thermostat calls.

**SLOW AMBER FLASH:** Normal operation with call for heat.

**LED STEADY OFF** – If the LED light does not flash at all, check for power to the control board and check for an open fuse on the control board. If the control board is adequately powered and the fuse is not open, the control board may need to be replaced.

**STEADY ON ANY COLOR:** Possible control failure. Turn power to the furnace off and back on. If the fault code returns, the control board must be replaced. The control board is not field-repairable.

**RAPID AMBER FLASH:** This indicates low flame sense current.

**ALTERNATING RED AND AMBER FLASH:** This indicates a refrigerant leak detected near the furnace.

**1 RED FLASH:** This indicates that flame was sensed when there was not a call for heat. The control turns on both the inducer motor and supply air blower. Check for a leaking or slow-closing gas valve.

**2 RED FLASHES:** This indicates that the pressure switch is closed when it should be open. The control confirms that the pressure switch contacts are open at the beginning of each heat cycle and does not let the ignition sequence continue if the pressure switch contacts are closed when they should be open. Check for a faulty pressure switch or miswiring.

**3 RED FLASHES:** This indicates the pressure switch contacts are open when they should be closed. Check for faulty inducer, blocked vent pipe, broken pressure switch hose, disconnected pressure switch or inducer wires or faulty pressure switch.

**4 RED FLASHES:** This indicates that the main limit switch has opened its normally closed contacts. The control operates the supply air blower and inducer while the open limit condition exists. Check for a dirty filter, incorrectly sized duct system, incorrect blower speed setting, incorrect firing rate, loose limit switch wiring or faulty blower motor.

If the limit switch has not closed within 5 min, the control assumes that the blower is not functioning, starts a hard lockout and begins to flash the 11 Red Flashes error code. Power has to be cycled off and on to reset the control after the problem has been corrected. See the 11 Red Flashes description below.

If the main limit switch opens five times within a single call for heat, the control also indicates 4 Red Flashes and enters a one-hour soft lockout.

**5 RED FLASHES:** This fault is indicated if the normally closed rollout switch opens or if the limit switch has been open longer than 15 min. The rollout control is manually reset. Check for adequate combustion air, correct inducer operation, and primary heat exchanger failure or burner problem. The control enters a hard lockout and power has to be cycled off and on to reset the control after the problem has been corrected.

**6 RED FLASHES:** This indicates that while the unit was operating, the pressure switch opened four times during the call for heat. Check for faulty inducer, blocked vent pipe or faulty pressure switch. The furnace locks out for 1 h and then restarts.

**7 RED FLASHES:** This fault code indicates that the flame could not be established during three trials for ignition. Check that the gas valve switch is in the ON position. Check for low or no gas pressure, faulty gas valve, dirty or faulty flame sensor, faulty hot surface ignitor, loose wires or a burner problem. The furnace locks out for 1 h and then restarts.

**8 RED FLASHES:** This fault is indicated if the flame is lost five times (four recycles) during the heating cycle. Check for low gas pressure, dirty or faulty flame sensor or faulty gas valve. The furnace locks out for 1 h and then restarts.

**9 RED FLASHES:** Indicates reversed line voltage polarity, grounding problem or reversed low voltage transformer wires. Both heating and cooling operations are affected. Check polarity at furnace and branch. Check furnace grounding. Check that flame probe is not shorted to chassis. The furnace does not start the ignition sequence until this problem is corrected.

**10 RED FLASHES:** Gas valve energized with no call for heat. The main blower and inducer blower run and no ignition sequence is started as long as this condition exists. Check gas valve and gas valve wiring.

**11 RED FLASHES:** This indicates that the main limit switch has opened its normally-closed contacts and has remained open for more than 5 min. This condition is usually caused by a failed blower motor or blower wheel. The control enters a hard lockout and power has to be cycled off and on to reset the control after the problem has been corrected.

**14 RED FLASHES:** If the secondary voltage drops below approximately 19 VAC, the control continues to energize any relays that are already energized, but does not energize any additional relays until the voltage level increases.

**15 RED FLASHES:** If the secondary voltage drops below approximately 16 VAC, the control immediately de-energizes the relay outputs and does not energize any relays until the voltage level increases above approximately 20 VAC.

**4 AMBER FLASHES:** The control is receiving a **Y** signal from the thermostat without a **G** signal. The furnace operates normally in both heating and cooling, but this status code is displayed in order to alert the user that there is a wiring problem. Verify that the **G** wire from the thermostat is connected correctly.

**SOFT LOCKOUT:** This control includes a soft lockout that resets automatically after 1 h. This provides protection to an unoccupied structure if a temporary condition exists causing a furnace malfunction. An example of this is a temporary interruption in gas supply that would prevent the furnace from lighting. The control keeps trying to light each hour and resumes normal operation if the gas supply is restored.

**HARD LOCKOUT:** Some fault conditions result in a hard lockout, which requires power to the control to be turned off and then back on to reset the control. The control does not automatically restart.

IGNITION CONTROL FLAME SENSE LEVELS

Normal flame sense current is  
approximately 3.7 microamps DC ( $\mu\text{a}$ )

Low flame signal warning starts at 1.5 microamps.

Low flame signal control lockout point is  
0.1 microamps DC ( $\mu\text{a}$ )

## Diagnostic fault code storage and retrieval

The control in this furnace is equipped with memory that stores up to five error codes to allow a service technician to diagnose problems more easily. This memory is retained even if power to the furnace is lost. **This feature must only be used by a qualified service technician.**

If more than five error codes have occurred, only the five most recent are retained. The furnace control board has a button, labeled LAST ERROR, that is used to retrieve error codes. This function only works if there are no active thermostat signals. Any call for heating, cooling, or continuous fan must be terminated before attempting to retrieve error codes.

To retrieve the error codes, push and release LAST ERROR button. The LED on the control then flashes the error codes that are in memory, starting with the most recent. There is a 2 s pause between each flash code. After the error codes have all been displayed, the LED resumes the normal slow green flash after a 5 s pause. To repeat the series of error codes, push the button again.

If there are no error codes in memory, the LED flashes two green flashes. To clear the memory, push the LAST ERROR button and hold it for more than 5 s. The LED flashes three green flashes when the memory has been cleared, then resumes the normal slow green flash after a 5 s pause.

## Replacement parts list

Description
<b>Motor</b>
MOTOR, DIRECT DRIVE BLOWER
BLOWER, COMBUSTION
<b>Electrical</b>
SWITCH, LIMIT
CONTROL, FURNACE
IGNITER
SENSOR, FLAME
SWITCH, PRESSURE
SWITCH, DOOR
TRANSFORMER
VALVE, GAS
CONTROL, TEMPERATURE
<b>Air moving</b>
HOUSING, BLOWER
HOUSING, BLOWER with WHEEL
WHEEL, BLOWER
<b>Fabricated parts</b>
BURNER, MAIN GAS
BRACKET, IGNITER
SHELF, BLOWER
BRACKET, BLOWER TRACK (Two required)
HEAT EXCHANGER ASSEMBLY

### Replacement part contact information

- Visit our website at <http://www.source1parts.com> for the following information:
  - a. Search for a part or browse the catalog.
  - b. Find a dealer or distributor.
  - c. Customer Service contact information.
    - i. Click on the **Brand Links** button
    - ii. Click on the **Customer Service** button

Description
MANIFOLD, GAS
PAN, BOTTOM
PANEL, TOP
PANEL, DOOR (Two required)
VENT PAN, COMBUSTION (with Gasket)
PANEL, BLOCKOFF
LO-NOX SCREEN (LO-NOx Models Only)
<b>Miscellaneous</b>
ORIFICE, BURNER (Natural No. 45)
SIGHT GLASS, OVAL (Two required)
GASKET, FOAM (Door) (1.5 ft required)
GASKET, INTAKE PAN
PLUG, VENT HOLE
BRACKET, DOOR
WIRING HARNESS
FERRULE (Three required)
GROMMET (Three required)
MOTOR MOUNT
TUBING, SILICON
DIAGRAM, WIRING
KNOB, QUARTER TURN (Four required)

This is a generic parts list. To request a complete parts list, refer to the contact information below:

- You can contact us by mail by sending a written request to:

**Johnson Controls Ducted Systems  
Consumer Relations  
5005 York Drive  
Norman, OK 73069**

**Third-Party Trademarks Notice:** For information about third-party trademarks, refer to the relevant company websites.

# Wiring diagram

## WIRING DIAGRAM - SINGLE STAGE STD ECM NON-CONDENSING FURNACE

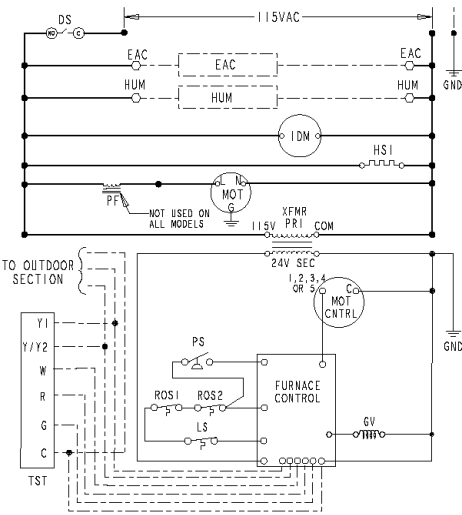
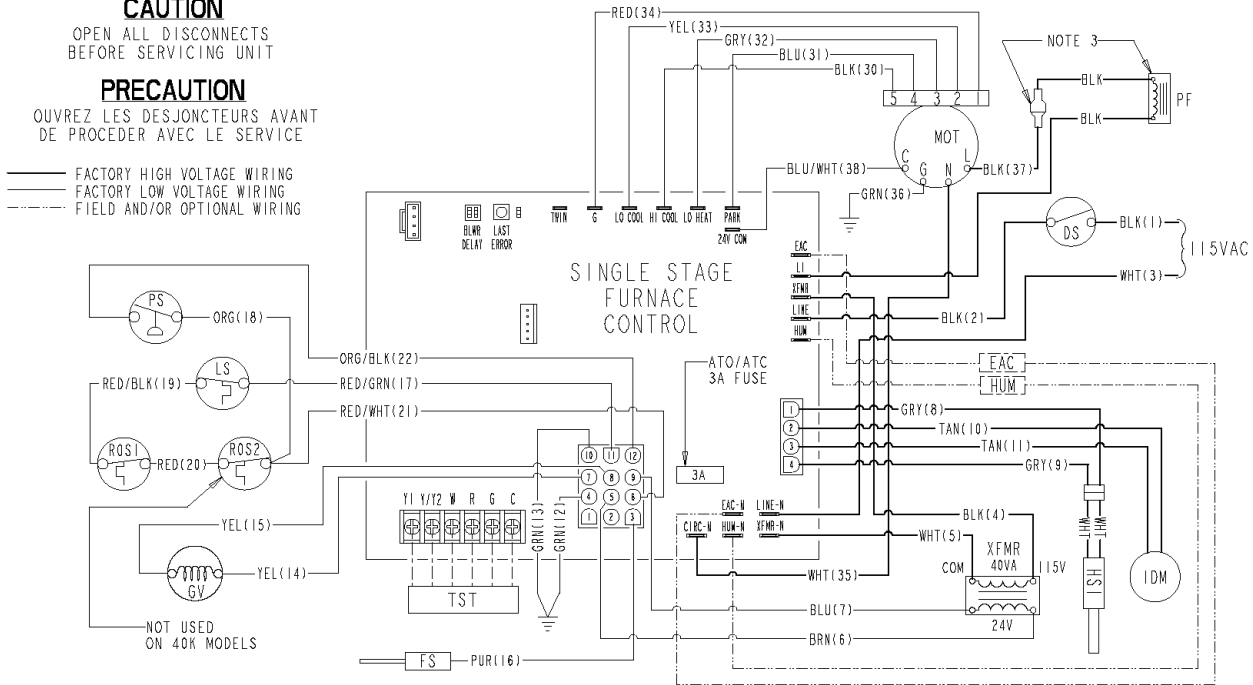
### CAUTION

OPEN ALL DISCONNECTS BEFORE SERVICING UNIT

### PRECAUTION

OUVREZ LES DESJONCTEURS AVANT DE PROCEDER AVEC LE SERVICE

— FACTORY HIGH VOLTAGE WIRING  
 - - - FACTORY LOW VOLTAGE WIRING  
 ······ FIELD AND/OR OPTIONAL WIRING



### DIAGNOSTIC CODES

FLASHES	CONDITION
NONE	POWER OFF OR OPEN FUSE
GREEN HEARTBEAT	NORMAL OPERATION
AMBER HEARTBEAT	NORMAL OPERATION WITH CALL FOR HEAT
RAPID GREEN	CONTROL IN FACTORY TEST MODE
STEADY ON (ANY COLOR)	CONTROL FAILURE
RAPID AMBER	LOW FLAME SENSE CURRENT
ALT. RED/AMBER	REFRIGERANT LEAK DETECTED NEAR FURNACE
1 RED FLASH	FLAME PRESENT WITH GV OFF
2 RED FLASHES	PS CLOSED WITH IDM OFF
3 RED FLASHES	PS OPEN WITH IDM ON
4 AMBER FLASHES	*Y* T-STAT CALL WITHOUT "G" CALL
4 RED FLASHES	LS / ROS SWITCH OPEN
5 RED FLASHES	LS / ROS OPEN GREATER THAN 15 MIN.
6 RED FLASHES	PS CYCLE LOCKOUT
7 RED FLASHES	LOCKOUT DUE TO FAILED IGNITION
8 RED FLASHES	LOCKOUT DUE TO FLAME DROPOUTS
9 RED FLASHES	INCORRECT LINE POLARITY/TWINNING FAULT
10 RED FLASHES	GV FAULT
11 RED FLASHES	LS/ROS OPEN FROM 5 TO 15 MIN.
14 RED FLASHES	LOW VOLTAGE < 19.2VAC - PREVENTS FURTHER RELAY OUTPUTS FOR > 2 SECONDS
15 RED FLASHES	LOW VOLTAGE < 16 VAC - STOPS CURRENT RELAY OUTPUTS FOR > 2 SECONDS

### LEGEND

- DS - DOOR SWITCH
- EAC - ELECTRONIC AIR CLEANER
- FS - FLAME SENSOR
- GV - GAS VALVE
- HSI - HOT SURFACE IGNITOR
- HUM - HUMIDIFIER
- IDM - INDUCED DRAFT MOTOR
- LS - LIMIT SWITCH
- MOT - BLOWER MOTOR
- PF - POWER FACTOR CHOKE
- PS - PRESSURE SWITCH
- ROS - ROLLOUT SWITCH
- TST - THERMOSTAT
- XFMR - TRANSFORMER

### LEGENDE

- DS - COMMUTATEUR DE PORTE
- EAC - FILTRE ELECTRIQUE
- FS - CAPTEUR DE FLAMME
- GV - ROBINET DE GAZ
- HSI - IGNITION DE SURFACE CHAUD
- HUM - HUMIDIFICATEUR
- IDM - VENTILATEUR DE COMBUSTION
- LS - COMMUTATEUR DE LIMITE
- MOT - BLOWEUR MOTEUR
- PF - TRANSFORMEUR DE FACTEUR DE PUISSANCE
- PS - CAPTEUR DE PRESSION
- ROS - COMMUTATEUR DE ROULEMENT
- TST - THERMOSTAT
- XFMR - TRANSFORMEUR

### NOTES:

- If any of the original wire as supplied with the furnace must be replaced, it must be replaced with wiring having a temperature rating of at least 221°F (105°C).
- Blower motor speed connections shown are typical and may vary by model and application.
- PF Choke installed with 3/4 - IHP motors only. BLK(37) connects to Control "L1" when not equipped with PF Choke.
- Connectors suitable for copper conductors only.

### NOTES:

- Si l'un des fils d'origine fourni avec ce four doit être remplacé, il doit être remplacé avec le fil ayant un degré de température d'au moins 221°F (105°C).
- Les connexions de vitesse du moteur de ventilateur illustrées sont typiques et peuvent varier selon le modèle et l'application.
- PF installé avec des moteurs 3/4 - IHP uniquement. BLK(37) se connecte pour contrôler "L1" lorsqu'il n'est pas équipé de PF.
- Seulement des marteaux pour fil de cuivre.

Refer to Installation Manual for more detailed information

**FAULT CODE RETRIEVAL** - Only a qualified service technician should use this feature.

6088313-UWD-A-0521





# Start-up sheet

## 33 in. Non-condensing Single Stage Gas Furnace Start-up Sheet

Correct furnace start-up is critical to customer comfort and equipment longevity

Start-up date

Technician performing start-up

Installing contractor name

### Owner information

Name

Address

City

State or province

Zip or postal code

### Equipment data

Furnace model

Furnace serial

Evaporator coil model

Evaporator coil serial

Outdoor unit model

Outdoor unit serial

### Furnace configuration

Upflow     Downflow     Horizontal left     Horizontal right

### Filter, thermostat, accessories

Filter type  Filter size  Filter locations

Thermostat type  Other system equipment and accessories

### Connections - all per installation instructions and local code

Unit is level     Gas piping is connected (including drip leg)     Supply plenum and return air are connected  
 Vent system is connected

### Venting: b vent

Vertical termination    Vent pipe size     Number of 90° ells     Number of 45° ells     Total height   
    Connector size     Connector length

Horizontal termination (with external power vent)    Vent pipe size     Number of 90° ells     Number of 45° ells

### Venting: lined masonry chimney

B vent connector     Single wall connector    Connector size     Connector length     Chimney height

Number of 90° ells     Number of 45° ells

#### Other appliances in same common vent:

Water heater  Btu/h input     Fan assisted?  Y  N

Furnace  Btu/h input     Fan assisted?  Y  N

Other  Btu/h input     Fan assisted?  Y  N

Venting system is the correct size, within the limitations of the chart in the installation instructions, correctly connected to the furnace, and correctly pitched.

### Electrical: line voltage

Polarity is correct (black is L1 (hot), white is N (neutral))     Ground wire is connected    Line voltage to furnace (AC)

### Electrical: low voltage

Thermostat wiring is complete     Thermostat heat anticipator set to 0.45 (if present)

Low voltage value between "R" and "C" on furnace control board (VAC)

Continued on next page

### Gas side

Gas type  Natural gas  LP gas (requires LP conversion kit)

LP gas conversion kit part number  LP conversion kit installed by

Inlet gas pressure (in. W.C.)  Manifold gas pressure (in. W.C.)

Calculated input in Btu/h - clock the gas meter (natural gas only)

Burner flame inspected - flames are blue and extending directly into the primary heat exchanger cells

### Air side: system external static pressure

Supply static before evaporator coil (in W.C.)  Supply static after evaporator coil (in W.C.)

Return static (in W.C.) before filter  Return static (in W.C.) after filter (furnace side)

Total external static pressure

### Air side: heating

Blower speed selected (standard ECM)  5-red (low)  4-yellow (medium low)  3-gray (medium)  2-blue (medium high)  
 1-black (high)

Blower speed selected  Supply air dry bulb (°F)  Temperature drop (°F)

### Air side: cooling

Blower speed selected (standard ECM)  5-red (low)  4-yellow (medium low)  3-gray (medium)  2-blue (medium high)  
 1-black (high)

Return air dry bulb (°F)  Return air wet bulb (°F)  Blower performance data chart cooling CFM

Supply air dry bulb (°F)  Supply air wet bulb (°F)

Temperature drop (°F)  Outside air dry bulb (°F)

### Air side: continuous fan

Blower speed selected (standard ECM)  5-red (low)  4-yellow (medium low)  3-gray (medium)  2-blue (medium high)  
 1-black (high)

### Cycle test

- Operate the furnace through several heating cycles from the thermostat, noting and correcting any problems
- Operate the furnace through continuous fan cycles from the thermostat, noting and correcting any problems
- Operate the furnace through cooling cycles (as applicable), noting and correcting any problems

### Clean up

Installation debris disposed of and furnace area cleaned up?

### Owner education

- Give owner the owner's manual provided
- Explain operation of system to equipment owner
- Explain the importance of regular filter replacement and equipment maintenance
- Explain thermostat use and programming (if applicable) to owner

### Additional job detail