

INSTALLATION MANUAL

SINGLE PACKAGE HEAT PUMP/ELECTRIC HEAT

MODELS: PHE6 SERIES

2 TO 5 TONS – 208/230 V - 1 PHASE



LIST OF SECTIONS

GENERAL INFORMATION	1	OPERATION	16
SAFETY	1	MAINTENANCE	20
MODEL NUMBER NOMENCLATURE	2	TYPICAL WIRING DIAGRAMS	21
INSTALLATION	2	START UP SHEET	25
AIRFLOW PERFORMANCE	13		

LIST OF FIGURES

Component Location	3	Single Point Wiring Kits	11
Unit 4 Point Load Weight	4	Demand Defrost Control	18
Unit Dimensions	4	Blower Control	18
Bottom Duct Dimensions (in.)	5	Measuring External Static Pressure	20
Rear Duct Dimensions (in.)	5	Connection Wiring Diagram	21
Typical Field Control Wiring Diagram for Heat Pump Models	6	Ladder Wiring Diagram	22
Typical Field Power Wiring Diagram	6	R-410A Quick Reference Guide	23

LIST OF TABLES

Unit Limitations	2	Electric Heat Multipliers	15
Application Limitations	3	Recommended Blower Speed for Electric Heat	15
Weights and Dimensions	4	Electric Heat Blower Off Delay	15
Unit Dimensions	4	Additional Static Resistance	16
Unit Clearances	5	Indoor Blower Control Fault Codes	17
Electrical Data for 208/230-1-60 Single Source Power	7	Delay Profile Descriptions	17
Electrical Data for 208-1-60 Multi Source Power	8	Demand Defrost Selection	18
Electrical Data for 230-1-60 Multi Source Power	9	Test Pins	19
Single Point Kit Numbers	11	Demand Defrost Fault Codes	19
Physical Data	12	Thermostat Signals	19
Airflow Performance - Side Duct Application	13		

SECTION I: GENERAL INFORMATION

PHE units are factory assembled heat pumps designed for outdoor installation on a roof top or a slab. Field-installed optional electric heater accessories are available to provide supplemental electric heat combined with electric cooling and heating.

The units are completely assembled on rigid, removable base rails. All piping, refrigerant charge, and electrical wiring is factory installed and tested. The units require only electric power condensate drain and duct connections at the point of installation.

SECTION II: SAFETY



This is a safety alert symbol. When you see this symbol on labels or in manuals, be alert to the potential for personal injury.

Understand and pay particular attention to the signal words **DANGER**, **WARNING**, or **CAUTION**.

DANGER indicates an **imminently hazardous** situation, which, if not avoided, **will result in death or serious injury**.

WARNING indicates a **potentially hazardous** situation, which, if not avoided, **could result in death or serious injury**.

CAUTION indicates a potentially hazardous situation, which, if not avoided **may result in minor or moderate injury**. It is also used to alert against unsafe practices and hazards involving only property damage.

⚠ WARNING

*Improper installation may create a condition where the operation of the product could cause personal injury or property damage. Improper installation, adjustment, alteration, service or maintenance can cause injury or property damage. **Failure to carefully read and follow all instructions in this manual can result in furnace malfunction, death, personal injury and/or property damage.** Only a qualified contractor, installer or service agency should install this product.*

⚠ CAUTION

This product must be installed in strict compliance with the installation instructions and any applicable local, state, and national codes including, but not limited to building, electrical, and mechanical codes.

⚠ WARNING

Before performing service or maintenance operations on unit, turn off main power switch to unit. Electrical shock could cause personal injury. Improper installation, adjustment, alteration, service or maintenance can cause injury or property damage. Refer to this manual. For assistance or additional information consult a qualified installer, service agency or the gas supplier.

⚠ CAUTION

This system uses R-410A Refrigerant which operates at higher pressures than R-22. No other refrigerant may be used in this system. Gage sets, hoses, refrigerant containers and recovery systems must be designed to handle R-410A. If you are unsure, consult the equipment manufacturer. Failure to use R-410A compatible servicing equipment may result in property damage or injury.

Due to system pressure, moving parts, and electrical components, installation and servicing of air conditioning equipment can be hazardous. Only qualified, licensed service personnel should install, repair, or service this equipment. Unlicensed personnel can perform basic maintenance functions of cleaning coils and filters and replacing filters.

Observe all precautions in the literature, labels, and tags accompanying the equipment when working on air conditioning equipment. Install this product in strict compliance with the installation instructions and any applicable local, state, and national codes including, but not limited to building, electrical, and mechanical codes.

Wear safety glasses and work gloves. Use quenching cloth and have a fire extinguisher available during brazing operations.

INSPECTION

As soon as a unit is received, it should be inspected for possible damage during transit. If damage is evident, the extent of the damage should be noted on the carrier's freight bill. A separate request for inspection by the carrier's agent should be made in writing.

REPLACEMENT PARTS

Contact your local Ducted Systems parts distribution center for authorized replacement parts.

SECTION III: MODEL NUMBER NOMENCLATURE

PHE	4	A	24		2		1	A		
1	2	3	4	5	6	7	8	9		
1. Model Family PHE - packaged heat pump with electric heat PCG - packaged A/C with gas heat PHG - packaged heat pump with gas heat PCE - packaged A/C with electric heat				5. Gas Heating Input BTU/Hr x 1000 050 = 50,000 BTU/Hr input, blank = electric heat						
2. Nominal Cooling Efficiency 4 = 14 SEER, 6 = 16 SEER				6. Voltage-Phase-Frequency 2 = 208/230-1-60, 3 = 208/230-3-60, 4 = 460-3-60						
3. Cabinet Size A = small 35 x 51, B = large 45 x 51				7. NOx Approval X = low-NOx, blank = not low-NOx						
4. Nominal Air Conditioning Cooling Capacity BTUx1000 24 = 24,000 BTU, etc.				8. Generation Level 1 = first generation						
				9. Revision Level A = original release, B = second release						
Example: PHE6B4221A is a packaged heat pump, 16 SEER, large cabinet, 3-1/2 ton, 208/230 V, single-phase model, first generation, first release.										

SECTION IV: INSTALLATION**LIMITATIONS**

These units must be installed in accordance with the following national and local safety codes.

- National Electrical Code ANSI/NFPA No. 70 or Canadian Electrical Code Part 1, C22.1 (latest editions)
- Local plumbing and waste water codes and other applicable local codes

See Tables 3 and 4 for unit physical data and Tables 6 to 8 for electrical data.

If components are to be added to a unit to meet local codes, they are to be installed at the dealer's and/or the customer's expense.

The size of the unit for proposed installation should be based on heat loss/heat gain calculations made in accordance with industry recognized procedures such as the Air Conditioning Contractors of America (manual J).

Table 1: Unit Limitations

Model	Unit Voltage	Unit Limitations		
		Applied Voltage		Outdoor DB Temperature
		Minimum	Maximum	Maximum (°F)
PHE6A24	208/230-1-60	187	252	125
PHE6A30	208/230-1-60	187	252	125
PHE6B36	208/230-1-60	187	252	125
PHE6B42	208/230-1-60	187	252	125
PHE6B48	208/230-1-60	187	252	125
PHE6B60	208/230-1-60	187	252	125

Table 2: Application Limitations

Packaged Equipment Series	Air Temperature at Outdoor Coil (°F)				Air Temperature at Indoor Coil (°F)			
	Minimum		Maximum		Minimum		Maximum	
	DB Cool	DB Heat	DB Cool	DB Heat	WB Cool	DB Heat	WB Cool	DB Heat
16 SEER HP	55	-10	125	75	57	50	72	80

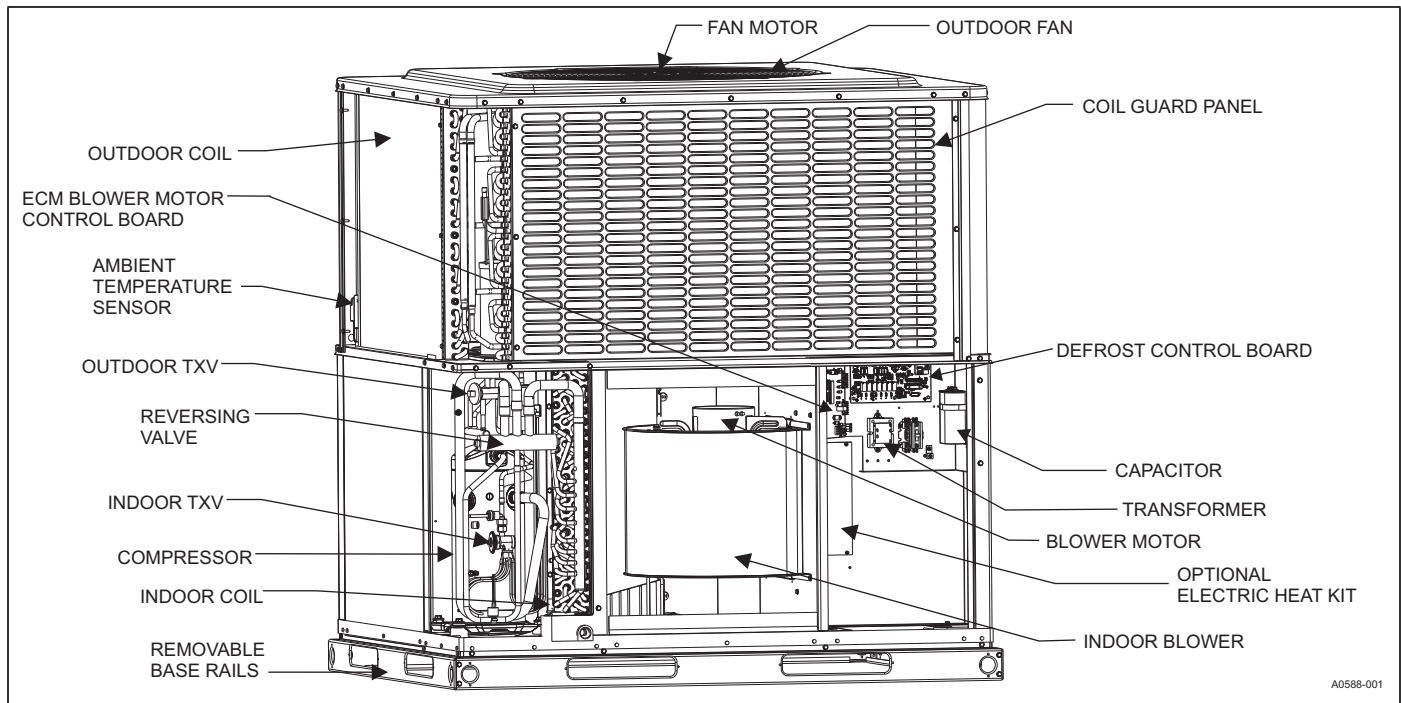
**Figure 1:** Component Location**LOCATION**

Use the following guidelines to select a suitable location for these units:

⚠ WARNING

Do not attach supply and return duct work to the bottom of the unit base pan as the drain pan could be compromised.

- The unit is designed for **outdoor installation** only.
- Outdoor coils must have an unlimited supply of air. Where a choice of location is possible, position the unit on either the north or east side of the building.
- Suitable for mounting on a roof curb.
- For ground level installation, a level pad or slab should be used. The thickness and size of the pad or slab used should meet local codes and support the unit weight. Do not tie the slab to the building foundation.
- Roof structures must be able to support the weight of the unit and its options/accessories. The unit must be installed on a solid, level roof curb or an appropriate angle iron frame.
- Maintain level tolerance to 1/8 in. across the entire width and length of the unit.

CLEARANCES

⚠ WARNING

Do not permit overhanging structures or shrubs to obstruct outdoor air discharge outlet.

All units require certain clearances for proper operation and service. Refer to Table 5 for the clearances required for construction, servicing and proper unit operation.

RIGGING AND HANDLING

⚠ CAUTION

If a unit is to be installed on a roof curb other than a Unitary Products roof curb, gasket or sealant must be applied to all surfaces that come in contact with the unit underside.

⚠ CAUTION

All panels must be secured in place when the unit is lifted. The outdoor coils should be protected from rigging cable damage with plywood or other suitable material.

Exercise care when moving the unit. Do not remove any packaging until the unit is near the place of installation. Rig the unit by attaching chain or cable slings to the lifting holes provided in the base rails. Spreader bars, whose length exceeds the largest dimension across the unit, **MUST** be used across the top of the unit.

⚠ CAUTION

Before lifting, make sure the unit weight is distributed equally on the rigging cables so it will lift evenly.

Units may be moved or lifted with a forklift. Slotted openings in the base rails are provided for this purpose.

Table 3: Weights and Dimensions

Model	Weight (lb)		Center of Gravity		4 Point Load Location (lb)			
	Shipping	Operating	X	Y	A	B	C	D
PHE6A24	382	377	29	15	133	88	86	75
PHE6A30	397	392	29	15	127	101	99	70
PHE6B36	453	448	29	15	158	108	101	86
PHE6B42	476	471	30	15	164	119	111	82
PHE6B48	501	496	29	15	168	130	119	84
PHE6B60	528	523	30	15	177	136	128	87

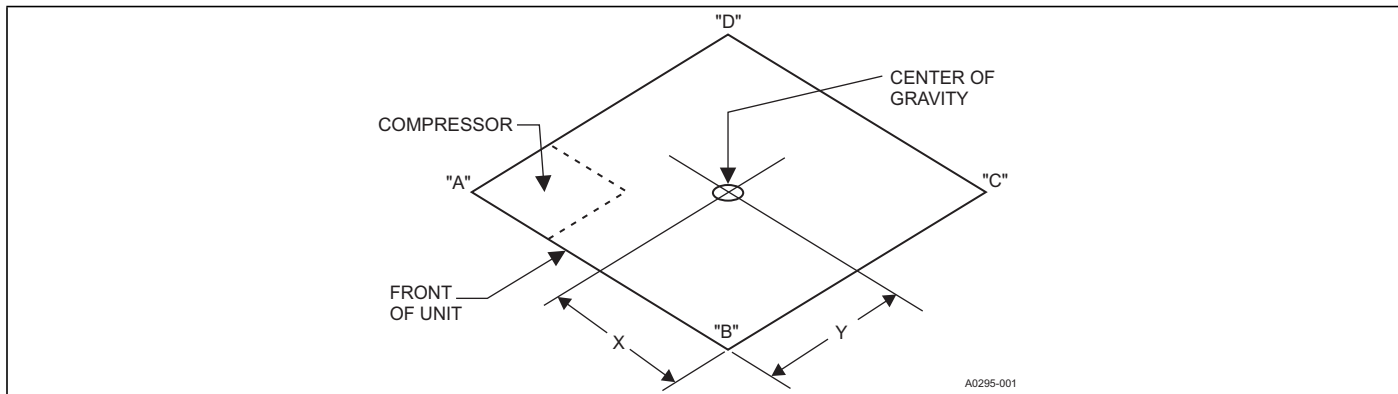

Figure 2: Unit 4 Point Load Weight

Table 4: Unit Dimensions

Model	Dimensions (in.)		
	A	B	C
PHE6A24	51-1/4	35-3/4	47
PHE6A30	51-1/4	35-3/4	47
PHE6B36	51-1/4	45-3/4	49
PHE6B42	51-1/4	45-3/4	49
PHE6B48	51-1/4	45-3/4	53
PHE6B60	51-1/4	45-3/4	55

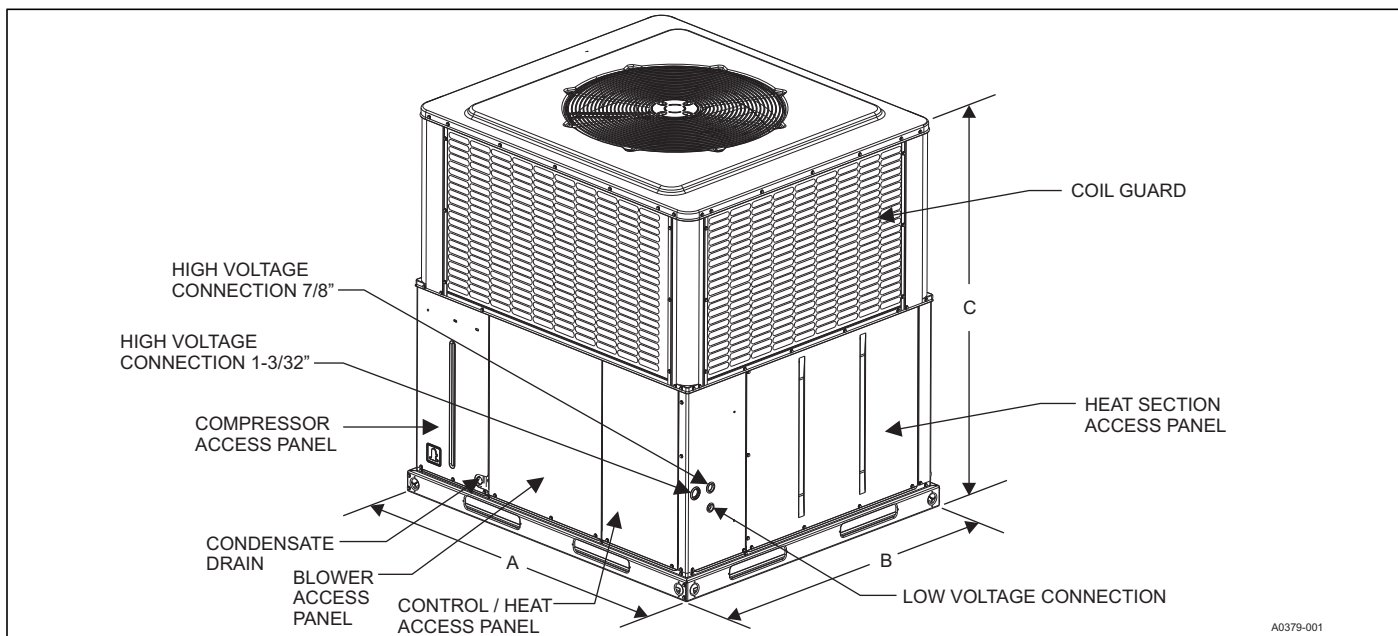

Figure 3: Unit Dimensions

Table 5: Unit Clearances

Direction	Distance (in.)	Direction	Distance (in.)
Top ¹	36	Right Side	36
Side Opposite Ducts	36	Left Side	24
Duct Panel	0	Bottom ^{2 3}	1

- There must be a minimum clearance of 1 in. on all sides of the supply air duct for the first 3 ft of the duct for 20 kW and 25 kW heaters (0 in. thereafter). For all other heaters, there must be a 0 in. clearance on all sides for the entire length of the supply air duct.
 - Units must be installed outdoors. Overhanging structures or shrubs must not obstruct the outdoor air discharge outlet.
 - Units can be installed on combustible materials made from wood or class A, B, or C roof covering materials if factory base rails are left in place as shipped.
- Note:** For units with a roof curb, the minimum clearance between combustible roof curb material and the supply air duct can be reduced from 1 in. to 1/2 in.

DUCTWORK

NOTICE

All units are shipped in the horizontal supply/return configuration. It is important to reduce the possibility of any air leakage through the bottom duct covers (resulting from cut, torn, or rolled gasket) due to improper handling or shipping processes. To ensure a good tight seal, it is recommended that silicone caulk and/or foil tape be applied along the cover edges.

These units are adaptable to downflow use as well as rear supply and return air duct openings. To convert to downflow:

- Remove the duct covers found in the bottom return and supply air duct openings. There are four screws securing each duct cover (save these screws to use in Step 2).
- Install the duct covers (removed in step one) to the rear supply and return air duct openings. Secure with the screws used in step one.
- Seal duct covers with silicone caulk.

Duct work should be designed and sized according to the methods of the Air Conditioning Contractors of America (ACCA), as set forth in their Manual D.

Use a closed return duct system. This does not preclude use of economizers or ventilation air intake. Flexible duct connectors are recommended in the supply and return duct work to minimize the transmission of vibration and noise.

CAUTION

When fastening duct work to the side duct flanges on the unit, insert the screws through the duct flanges only. DO NOT insert the screws through the casing. Outdoor duct work must be insulated and waterproofed.

NOTICE

Be sure to note supply and return openings.

Refer to Figures 4 and 5 for information concerning rear and bottom supply and return air duct openings.

FILTERS

Proper filter size is very important. Filter size, type, and pressure drop should always be considered during duct system design.

Single phase units are shipped without a filter or filter racks. It is the responsibility of the installer to secure a filter in the return air ductwork or install a Filter/Frame Kit.

A filter rack and high velocity filters are standard on three phase units.

Filters must always be used and must be kept clean. When filters become dirt laden, insufficient air is delivered by the blower, decreasing your unit's efficiency and increasing operating costs and wear-and-tear on the unit and controls.

Check filters monthly. This is especially important because this unit is used for both heating and cooling.

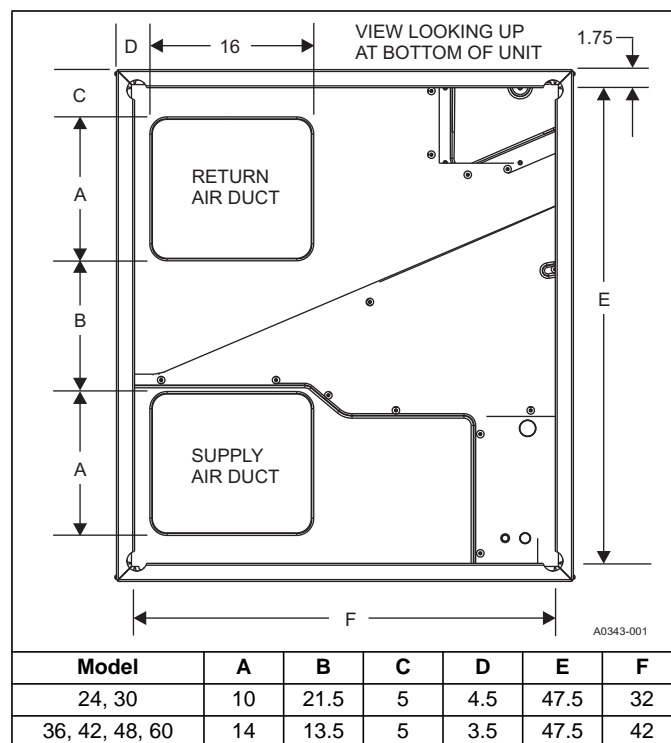

Figure 4: Bottom Duct Dimensions (in.)

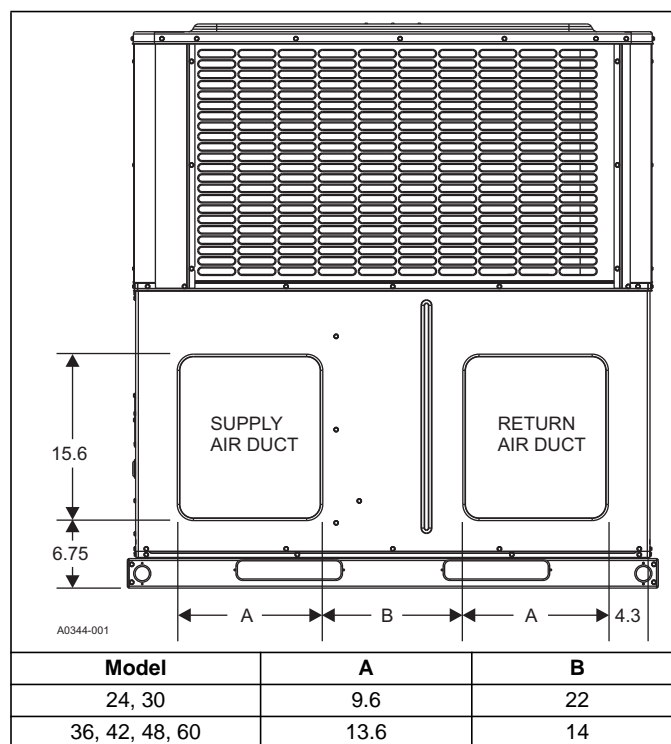

Figure 5: Rear Duct Dimensions (in.)

CONDENSATE DRAIN

A condensate trap must be installed in the condensate drain. The plumbing must conform to local codes.

⚠ CAUTION

Hand tighten only.

Use Teflon tape or pipe thread compound if needed.

SERVICE ACCESS

Access to all serviceable components is provided at the following locations:

- Coil guards
- Unit top panel
- Corner posts
- Blower access panel
- Control access panel
- Indoor coil access panel
- Compressor access panel
- Heat section access panel

See Figure 3 for the location of these access locations and see Table 5 for minimum clearances.

⚠ WARNING

Wear safety glasses and gloves when handling refrigerants. Failure to follow this warning can cause serious personal injury.

⚠ CAUTION

This system uses R-410A Refrigerant which operates at higher pressures than R-22. No other refrigerant may be used in this system. Gauge sets, hoses, refrigerant containers and recovery systems must be designed to handle R-410A. If you are unsure, consult the equipment manufacturer. Failure to use R-410A compatible servicing equipment may result in property damage or injury.

Refer to Figure 14 for the R-410A Quick Reference Guide.

THERMOSTAT

The room thermostat should be located on an inside wall approximately 60 in. above the floor where it is not subject to drafts, sun exposure, or heat from electrical fixtures or appliances. Sealant should be used behind thermostat to prevent air infiltration. Follow manufacturer's instructions enclosed with the thermostat for general installation procedure. Color coded insulated wires (minimum No. 18 AWG) should be used to connect thermostat to unit. See Figure 6.

If a field supplied electric heat kit is installed, this unit requires the use of a 3 heat/2 cool (3H/2C) heat pump thermostat for proper operation. For units installed with 6HK heat kits of 13 kW and larger, a 4H/2C heat pump thermostat should be used. Do not use power stealing thermostats.

POWER AND CONTROL WIRING

Field wiring to the unit must conform to provisions of the current N.E.C. ANSI/NFPA No. 70 or C.E.C. and/or local ordinances. The unit must be electrically grounded in accordance with local codes or, in their absence, with the N.E.C./C.E.C. Voltage tolerances that must be maintained at the compressor terminals during starting and running conditions are indicated on the unit Rating Plate and Table 1.

The wiring entering the cabinet must be provided with mechanical strain relief.

A fused disconnect switch should be field provided for the unit. If any of the wire supplied with the unit must be replaced, replacement wire must be of the type shown on the wiring diagram.

Electrical service must be sized properly to carry the load. Each unit must be wired with a separate branch circuit fed directly from the main distribution panel and properly fused.

Refer to Figures 6 and 7 for typical field wiring and to the appropriate unit wiring diagram for control circuit and power wiring information.

The unit comes wired for 230-V power. If supply power is 208 V, wires connected to the control transformer 230-V tap must be moved to the 208-V tap.

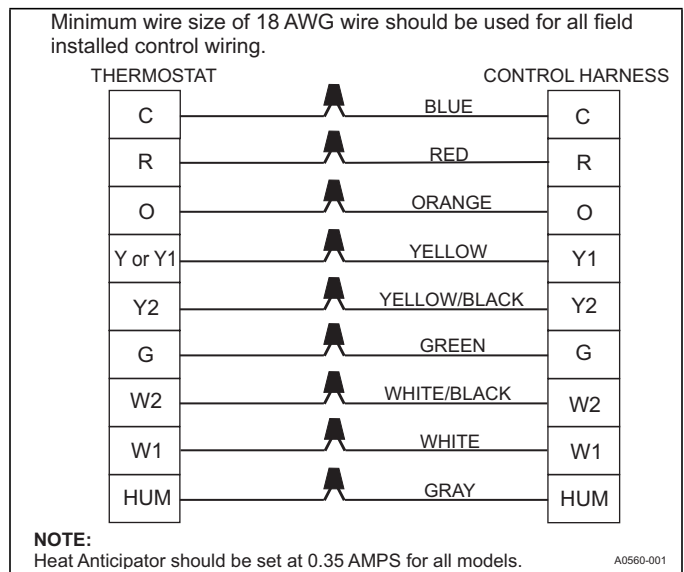

Figure 6: Typical Field Control Wiring Diagram for Heat Pump Models

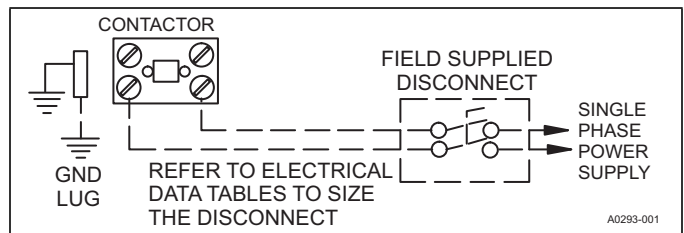

Figure 7: Typical Field Power Wiring Diagram

Table 6: Electrical Data for 208/230-1-60 Single Source Power

Model	Compressor			OD Fan Motor	Blower Motor	Electric Heat Option						MCA ¹ Amps		Max Fuse ² or Breaker Size ³	
	RLA	LRA	MCC	FLA	FLA	Heater Kit ⁴	Heater kW		Stages	Heater Amps		208	230	208	230
							208	230		208	230				
PHE6A24	11.7	58.3	18.2	0.7	3.8	none	--	--	--	--	--	19.2	19.2	30	30
						6HK16500206	1.8	2.2	1	8.7	9.6	30.0	31.2	35	40
						6HK16500506	3.6	4.4	1	17.3	19.1	40.9	43.1	45	50
						6HK16500806	5.8	7.1	1	27.9	30.9	54.1	57.8	60	60
						6HK16501006	7.2	8.8	1	34.6	38.3	62.5	67.1	70	70
						6HK16501306	9.4	11.5	2	45.2	50.0	75.7	81.7	80	90
PHE6A30	14.6	73.0	20.4	0.8	3.8	none	--	--	--	--	--	22.9	22.9	35	35
						6HK16500206	1.8	2.2	1	8.7	9.6	33.7	34.8	45	45
						6HK16500506	3.6	4.4	1	17.3	19.1	44.5	46.8	50	50
						6HK16500806	5.8	7.1	1	27.9	30.9	57.7	61.4	60	70
						6HK16501006	7.2	8.8	1	34.6	38.3	66.1	70.7	70	80
						6HK16501306	9.4	11.5	2	45.2	50.0	79.3	85.4	80	90
PHE6B36	15.6	83.0	24.4	1.7	3.8	none	--	--	--	--	--	25.0	25.0	40	40
						6HK16500206	1.8	2.2	1	8.7	9.6	35.8	37.0	40	50
						6HK16500506	3.6	4.4	1	17.3	19.1	46.6	48.9	50	50
						6HK16500806	5.8	7.1	1	27.9	30.9	59.9	63.6	60	70
						6HK16501006	7.2	8.8	1	34.6	38.3	68.3	72.8	70	80
						6HK16501306	9.4	11.5	2	45.2	50.0	81.5	87.5	90	90
PHE6B42	17.9	96.0	28.0	1.7	5.4	none	--	--	--	--	--	29.5	29.5	45	45
						6HK16500506	3.6	4.4	1	17.3	19.1	51.1	53.4	60	60
						6HK16500806	5.8	7.1	1	27.9	30.9	64.3	68.1	70	70
						6HK16501006	7.2	8.8	1	34.6	38.3	72.7	77.3	80	80
						6HK16501306	9.4	11.5	2	45.2	50.0	86.0	92.0	90	100
						6HK16501506	10.8	13.2	2	51.9	57.4	94.4	101.2	100	110
PHE6B48	21.2	104.0	33.0	1.7	5.4	none	--	--	--	--	--	33.6	33.6	50	50
						6HK16500506	3.6	4.4	1	17.3	19.1	55.2	57.5	70	70
						6HK16500806	5.8	7.1	1	27.9	30.9	68.5	72.2	80	80
						6HK16501006	7.2	8.8	1	34.6	38.3	76.9	81.4	80	90
						6HK16501306	9.4	11.5	2	45.2	50.0	90.1	96.1	100	100
						6HK16501506	10.8	13.2	2	51.9	57.4	98.5	105.3	100	110
PHE6B60	26.9	152.9	42.0	1.7	7	none	--	--	--	--	--	42.3	42.3	60	60
						6HK16500506	3.6	4.4	1	17.3	19.1	64.0	66.2	80	80
						6HK16500806	5.8	7.1	1	27.9	30.9	77.2	80.9	90	100
						6HK16501006	7.2	8.8	1	34.6	38.3	85.6	90.2	100	100
						6HK16501306	9.4	11.5	2	45.2	50.0	98.8	104.8	110	110
						6HK16501506	10.8	13.2	2	51.9	57.4	107.2	114.1	110	125
						6HK16501806	13.0	15.9	2	62.5	69.1	120.5	128.7	125	150
						6HK16502006	14.4	17.6	2	69.2	76.5	128.9	138.0	150	150

1. MCA = Minimum Circuit Ampacity.

2. Maximum Overcurrent Protection per standard UL 1995.

3. Fuse or HACR circuit breaker is field installed.

4. Single Point Connection Kit Required.

Table 7: Electrical Data for 208-1-60 Multi Source Power

Model	Compressor			OD Fan Motor	Blower Motor	Electric Heat Option				Multi Source									
	RLA	LRA	MCC			FLA	FLA	Heater Kit	Heater kW	Stages	Heater Amps	208	208	208	208	208	208	208	208
				208	208														
Multi Source: Compressor Circuit and Heat Circuits						Multi Source: Circuit 1 Compressor Circuit Circuit 2 Heat Circuit 3 Heat Circuit 4 Heat				MCA ¹ Amps	Max Fuse ² or Breaker Size ³	MCA ¹ Amps	Max Fuse ² or Breaker Size ³	MCA ¹ Amps	Max Fuse ² or Breaker Size ³	MCA ¹ Amps	Max Fuse ² or Breaker Size ³	MCA ¹ Amps	Max Fuse ² or Breaker Size ³
PHE6A24	11.70	58.3	18.2	0.8	3.8	none	--	--	--	19.2	30	--	--	--	--	--	--		
						6HK(0,1)6500206	1.8	1	8.7	19.2	30	10.8	15	--	--	--	--		
						6HK(0,1)6500506	3.6	1	17.3	19.2	30	21.6	25	--	--	--	--		
						6HK(0,1)6500806	5.8	1	27.9	19.2	30	34.9	40	--	--	--	--		
						6HK(0,1)6501006	7.2	1	34.6	19.2	30	43.3	45	--	--	--	--		
						6HK16501306	9.4	2	45.2	19.2	30	37.7	40	18.8	20	--	--		
PHE6A30	14.60	73.0	20.4	0.8	3.8	none	--	--	--	22.9	35	--	--	--	--	--	--		
						6HK(0,1)6500206	1.8	1	8.7	22.9	35	10.8	15	--	--	--	--		
						6HK(0,1)6500506	3.6	1	17.3	22.9	35	21.6	25	--	--	--	--		
						6HK(0,1)6500806	5.8	1	27.9	22.9	35	34.9	40	--	--	--	--		
						6HK(0,1)6501006	7.2	1	34.6	22.9	35	43.3	45	--	--	--	--		
						6HK16501306	9.4	2	45.2	22.9	35	37.7	40	18.8	20	--	--		
						6HK16501506	10.8	2	51.9	22.9	35	43.3	50	21.6	25	--	--		
						6HK26501306	9.4	2	45.2	22.9	35	56.5	60	--	--	--	--		
PHE6B36	15.60	83.0	24.4	1.7	3.8	none	--	--	--	25.0	40	--	--	--	--	--	--		
						6HK(0,1)6500206	1.8	1	8.7	25.0	40	10.8	15	--	--	--	--		
						6HK(0,1)6500506	3.6	1	17.3	25.0	40	21.6	25	--	--	--	--		
						6HK(0,1)6500806	5.8	1	27.9	25.0	40	34.9	40	--	--	--	--		
						6HK(0,1)6501006	7.2	1	34.6	25.0	40	43.3	45	--	--	--	--		
						6HK16501306	9.4	2	45.2	25.0	40	37.7	40	18.8	20	--	--		
						6HK16501506	10.8	2	51.9	25.0	40	43.3	50	21.6	25	--	--		
						6HK26501306	9.4	2	45.2	25.0	40	56.5	60	--	--	--	--		
PHE6B42	17.90	96.0	28.0	1.7	5.4	none	--	--	--	29.5	45	--	--	--	--	--	--		
						6HK(0,1)6500506	3.6	1	17.3	29.5	45	21.6	25	--	--	--	--		
						6HK(0,1)6500806	5.8	1	27.9	29.5	45	34.9	40	--	--	--	--		
						6HK(0,1)6501006	7.2	1	34.6	29.5	45	43.3	45	--	--	--	--		
						6HK16501306	9.4	2	45.2	29.5	45	37.7	40	18.8	20	--	--		
						6HK16501506	10.8	2	51.9	29.5	45	43.3	50	21.6	25	--	--		
						6HK16501806	13.0	2	62.5	29.5	45	39.1	40	39.1	40	--	--		
						6HK16502006	14.4	2	69.2	29.5	45	43.3	45	43.3	45	--	--		
						6HK26501306	9.4	2	45.2	29.5	45	56.5	60	--	--	--	--		
						6HK26501506	10.8	2	51.9	29.5	45	64.9	70	--	--	--	--		
PHE6B48	21.20	104.0	33.0	1.7	5.4	none	--	--	--	33.6	50	--	--	--	--	--	--		
						6HK(0,1)6500506	3.6	1	17.3	33.6	50	21.6	25	--	--	--	--		
						6HK(0,1)6500806	5.8	1	27.9	33.6	50	34.9	40	--	--	--	--		
						6HK(0,1)6501006	7.2	1	34.6	33.6	50	43.3	45	--	--	--	--		
						6HK16501306	9.4	2	45.2	33.6	50	37.7	40	18.8	20	--	--		
						6HK16501506	10.8	2	51.9	33.6	50	43.3	50	21.6	25	--	--		
						6HK16501806	13.0	2	62.5	33.6	50	39.1	40	39.1	40	--	--		
						6HK16502006	14.4	2	69.2	33.6	50	43.3	45	43.3	45	--	--		
						6HK26501306	9.4	2	45.2	33.6	50	56.5	60	--	--	--	--		
						6HK26501506	10.8	2	51.9	33.6	50	64.9	70	--	--	--	--		

Continued on next page. See notes at end of table.

Table 7: Electrical Data for 208-1-60 Multi Source Power (Continued)

Model	Compressor			OD Fan Motor	Blower Motor	Electric Heat Option				Multi Source							
						Heater Kit	Heater kW	Stages	Heater Amps	208	208	208	208	208	208	208	208
	208	208	MCA ¹ Amps	Max Fuse ² or Breaker Size ³	MCA ¹ Amps		Max Fuse ² or Breaker Size ³		MCA ¹ Amps								
Multi Source: Compressor Circuit and Heat Circuits						Multi Source: Circuit 1 Compressor Circuit Circuit 2 Heat Circuit 3 Heat Circuit 4 Heat				Circuit 1		Circuit 2		Circuit 3		Circuit 4	
						none	--	--	--	42.3	60	--	--	--	--	--	--
PHE6B60	26.90	152.9	42.0	1.7	7.0	6HK(0,1)6500506	3.6	1	17.3	42.3	60	21.6	25	--	--	--	--
						6HK(0,1)6500806	5.8	1	27.9	42.3	60	34.9	40	--	--	--	--
						6HK(0,1)6501006	7.2	1	34.6	42.3	60	43.3	45	--	--	--	--
						6HK16501306	9.4	2	45.2	42.3	60	37.7	40	18.8	20	--	--
						6HK16501506	10.8	2	51.9	42.3	60	43.3	50	21.6	25	--	--
						6HK16501806	13.0	2	62.5	42.3	60	39.1	40	39.1	40	--	--
						6HK16502006	14.4	2	69.2	42.3	60	43.3	45	43.3	45	--	--
						6HK26501306	9.4	2	45.2	42.3	60	56.5	60	--	--	--	--
						6HK26501506	10.8	2	51.9	42.3	60	64.9	70	--	--	--	--
						6HK26501806	13.0	2	62.5	42.3	60	78.1	80	--	--	--	--
						6HK26502006	14.4	2	69.2	42.3	60	86.5	90	--	--	--	--
						6HK16502506	18.0	2	86.5	42.3	60	43.3	45	43.3	45	21.6	25
						6HK26502506	18.0	2	86.5	42.3	60	108.2	110	--	--	--	--

1. MCA = Minimum Circuit Ampacity.
2. Maximum Overcurrent Protection per standard UL 1995.
3. Fuse or HACR circuit breaker is field installed.

Table 8: Electrical Data for 230-1-60 Multi Source Power

Model	Compressor			OD Fan Motor	Blower Motor	Electric Heat Option				Multi Source							
						Heater Kit	Heater kW	Stages	Heater Amps	230	230	230	230	230	230	230	230
	230	230	MCA ¹ Amps	Max Fuse ² or Breaker Size ³	MCA ¹ Amps		Max Fuse ² or Breaker Size ³		MCA ¹ Amps								
Multi Source: Compressor Circuit and Heat Circuits						Multi Source: Circuit 1 Compressor Circuit Circuit 2 Heat Circuit 3 Heat Circuit 4 Heat				Circuit 1		Circuit 2		Circuit 3		Circuit 4	
						none	--	--	--	19.2	30	--	--	--	--	--	--
PHE6A24	11.70	58.3	18.2	0.8	3.8	6HK(0,1)6500206	2.2	1	9.6	19.2	30	12.0	15	--	--	--	--
						6HK(0,1)6500506	4.4	1	19.1	19.2	30	23.9	25	--	--	--	--
						6HK(0,1)6500806	7.1	1	30.9	19.2	30	38.6	40	--	--	--	--
						6HK(0,1)6501006	8.8	1	38.3	19.2	30	47.8	50	--	--	--	--
						6HK16501306	11.5	2	50.0	19.2	30	41.7	45	20.8	25	--	--
						6HK26501306	11.5	2	50.0	19.2	30	62.5	70	--	--	--	--
						6HK26501506	13.2	2	57.4	19.2	30	71.7	80	--	--	--	--
PHE6A30	14.60	73.0	20.4	0.8	3.8	6HK(0,1)6500206	2.2	1	9.6	22.9	35	12.0	15	--	--	--	--
						6HK(0,1)6500506	4.4	1	19.1	22.9	35	23.9	25	--	--	--	--
						6HK(0,1)6500806	7.1	1	30.9	22.9	35	38.6	40	--	--	--	--
						6HK(0,1)6501006	8.8	1	38.3	22.9	35	47.8	50	--	--	--	--
						6HK16501306	11.5	2	50.0	22.9	35	41.7	45	20.8	25	--	--
						6HK16501506	13.2	2	57.4	22.9	35	47.8	50	23.9	25	--	--
						6HK26501306	11.5	2	50.0	22.9	35	62.5	70	--	--	--	--
						6HK26501506	13.2	2	57.4	22.9	35	71.7	80	--	--	--	--

Continued on next page. See notes at end of table.

Table 8: Electrical Data for 230-1-60 Multi Source Power

Model	Compressor			OD Fan Motor	Blower Motor	Electric Heat Option				Multi Source							
						Heater Kit	Heater kW	Stages	Heater Amps	230	230	230	230	230	230	230	230
	230	230	MCA ¹ Amps	Max Fuse ² or Breaker Size ³	MCA ¹ Amps		Max Fuse ² or Breaker Size ³		MCA ¹ Amps								
Multi Source: Compressor Circuit and Heat Circuits						Multi Source: Circuit 1 Compressor Circuit Circuit 2 Heat Circuit 3 Heat Circuit 4 Heat				Circuit 1		Circuit 2		Circuit 3		Circuit 4	
										MCA ¹ Amps	Max Fuse ² or Breaker Size ³	MCA ¹ Amps	Max Fuse ² or Breaker Size ³	MCA ¹ Amps	Max Fuse ² or Breaker Size ³	MCA ¹ Amps	Max Fuse ² or Breaker Size ³
PHE6B36	15.60	83.0	24.4	1.7	3.8	none	--	--	--	25.0	40	--	--	--	--		
						6HK(0,1)6500206	2.2	1	9.6	25.0	40	12.0	15	--	--	--	--
						6HK(0,1)6500506	4.4	1	19.1	25.0	40	23.9	25	--	--	--	--
						6HK(0,1)6500806	7.1	1	30.9	25.0	40	38.6	40	--	--	--	--
						6HK(0,1)6501006	8.8	1	38.3	25.0	40	47.8	50	--	--	--	--
						6HK16501306	11.5	2	50.0	25.0	40	41.7	45	20.8	25	--	--
						6HK16501506	13.2	2	57.4	25.0	40	47.8	50	23.9	25	--	--
						6HK26501306	11.5	2	50.0	25.0	40	62.5	70	--	--	--	--
6HK26501506	13.2	2	57.4	25.0	40	71.7	80	--	--	--	--						
PHE6B42	17.90	96.0	28.0	1.7	5.4	none	--	--	--	29.5	45	--	--	--	--		
						6HK(0,1)6500506	4.4	1	19.1	29.5	45	23.9	25	--	--	--	--
						6HK(0,1)6500806	7.1	1	30.9	29.5	45	38.6	40	--	--	--	--
						6HK(0,1)6501006	8.8	1	38.3	29.5	45	47.8	50	--	--	--	--
						6HK16501306	11.5	2	50.0	29.5	45	41.7	45	20.8	25	--	--
						6HK16501506	13.2	2	57.4	29.5	45	47.8	50	23.9	25	--	--
						6HK16501806	15.9	2	69.1	29.5	45	43.2	45	43.2	45	--	--
						6HK16502006	17.6	2	76.5	29.5	45	47.8	50	47.8	50	--	--
						6HK26501306	11.5	2	50.0	29.5	45	62.5	70	--	--	--	--
						6HK26501506	13.2	2	57.4	29.5	45	71.7	80	--	--	--	--
6HK26501806	15.9	2	69.1	29.5	45	86.4	90	--	--	--	--						
6HK26502006	17.6	2	76.5	29.5	45	95.7	100	--	--	--	--						
PHE6B48	21.20	104.0	33.0	1.7	5.4	none	--	--	--	33.6	50	--	--	--	--		
						6HK(0,1)6500506	4.4	1	19.1	33.6	50	23.9	25	--	--	--	--
						6HK(0,1)6500806	7.1	1	30.9	33.6	50	38.6	40	--	--	--	--
						6HK(0,1)6501006	8.8	1	38.3	33.6	50	47.8	50	--	--	--	--
						6HK16501306	11.5	2	50.0	33.6	50	41.7	45	20.8	25	--	--
						6HK16501506	13.2	2	57.4	33.6	50	47.8	50	23.9	25	--	--
						6HK16501806	15.9	2	69.1	33.6	50	43.2	45	43.2	45	--	--
						6HK16502006	17.6	2	76.5	33.6	50	47.8	50	47.8	50	--	--
						6HK26501306	11.5	2	50.0	33.6	50	62.5	70	--	--	--	--
						6HK26501506	13.2	2	57.4	33.6	50	71.7	80	--	--	--	--
6HK26501806	15.9	2	69.1	33.6	50	86.4	90	--	--	--	--						
6HK26502006	17.6	2	76.5	33.6	50	95.7	100	--	--	--	--						
PHE6B60	26.90	152.9	42.0	1.7	7.0	none	--	--	--	42.3	60	--	--	--	--		
						6HK(0,1)6500506	4.4	1	19.1	42.3	60	23.9	25	--	--	--	--
						6HK(0,1)6500806	7.1	1	30.9	42.3	60	38.6	40	--	--	--	--
						6HK(0,1)6501006	8.8	1	38.3	42.3	60	47.8	50	--	--	--	--
						6HK16501306	11.5	2	50.0	42.3	60	41.7	45	20.8	25	--	--
						6HK16501506	13.2	2	57.4	42.3	60	47.8	50	23.9	25	--	--
						6HK16501806	15.9	2	69.1	42.3	60	43.2	45	43.2	45	--	--
						6HK16502006	17.6	2	76.5	42.3	60	47.8	50	47.8	50	--	--
						6HK26501306	11.5	2	50.0	42.3	60	62.5	70	--	--	--	--
						6HK26501506	13.2	2	57.4	42.3	60	71.7	80	--	--	--	--
						6HK26501806	15.9	2	69.1	42.3	60	86.4	90	--	--	--	--
						6HK26502006	17.6	2	76.5	42.3	60	95.7	100	--	--	--	--
6HK16502506	22.0	2	95.7	42.3	60	47.8	50	47.8	50	23.9	25						
6HK26502506	22.0	2	95.7	42.3	60	119.6	125	--	--	--	--						

1. MCA = Minimum Circuit Ampacity.

2. Maximum Overcurrent Protection per standard UL 1995.

3. Fuse or HACR circuit breaker is field installed.

Table 9: Single Point Kit Numbers

Single Point Kit P/N	Unit Model Number	Breaker Size	Heat Kit
S1-2SPWK006	PHE6A24	25 A	Up to 13 kW
S1-2SPWK002	PHE6A30	35 A	Up to 15 kW
S1-2SPWK007	PHE6B36	40 A	Up to 15 kW
S1-2SPWK003	PHE6B42	45 A	Up to 20 kW
S1-2SPWK004	PHE6B48	50 A	Up to 20 kW
S1-2SPWK005	PHE6B60	60 A	Up to 20 kW

**Figure 8:** Single Point Wiring Kits

Table 10: Physical Data

NOMINAL TONNAGE	MODELS					
	PHE6A24	PHE6A30	PHE6B36	PHE6B42	PHE6B48	PHE6B60
	2.0	2.5	3.0	3.5	4.0	5.0
AHRI Cooling Performance						
Gross Capacity @ AHRI A point (MBH)	23.7	29.5	37.0	43.2	49.1	59.2
AHRI net capacity (MBH)	23.4	29.0	36.4	42.5	47.5	57.5
EER	12.5	12.5	12.5	12.5	12.5	12.5
SEER	16.0	16.0	16.0	16.0	16.0	16.0
Nominal CFM	800	1000	1200	1400	1600	1800
System power (kW)	1.8	2.3	2.8	3.3	3.7	4.5
Refrigerant type	R-410A	R-410A	R-410A	R-410A	R-410A	R-410A
Refrigerant charge (lb-oz)	9-0	10-0	12-12	11-8	15-0	15-8
AHRI Heating Performance						
47°F Capacity Rating (MBH)	22.2	27.2	33.8	38.0	45.5	56.0
System Power (kW/COP)	3.7	3.6	3.6	3.6	3.6	3.6
17°F Capacity Rating (MBH)	12.0	16.8	19.0	22.0	28.0	32.6
HSPF (BTU/Watts-hr.)	8.2	8.2	8.2	8.2	8.2	8.2
Dimensions (in.)						
Length	51-1/4	51-1/4	51-1/4	51-1/4	51-1/4	51-1/4
Width	35-3/4	35-3/4	45-3/4	45-3/4	45-3/4	45-3/4
Height	47	47	49	49	53	55
Operating Weight (lb)	377	392	448	471	496	523
Compressors						
Type	Scroll	Scroll	Scroll	Scroll	Scroll	Scroll
Stages	2	2	2	2	2	2
Outdoor Coil Data						
Face area (sq. ft)	15.1	16.9	19.5	19.5	23.8	25.9
Rows	2	2	2	2	2	2
Fins per inch	22	22	22	22	22	22
Tube diameter	3/8	3/8	3/8	3/8	3/8	3/8
Circuitry Type	Interlaced	Interlaced	Interlaced	Interlaced	Interlaced	Interlaced
Refrigerant control	TXV	TXV	TXV	TXV	TXV	TXV
Indoor Coil Data						
Face area (sq. ft)	4.6	4.6	6.3	6.3	6.3	6.3
Rows	3	3	3	3	3	4
Fins per inch	16	16	16	16	16	16
Tube diameter	3/8	3/8	3/8	3/8	3/8	3/8
Circuitry Type	Interlaced	Interlaced	Interlaced	Interlaced	Interlaced	Interlaced
Refrigerant control	TXV	TXV	TXV	TXV	TXV	TXV
Outdoor Fan Data						
Fan diameter (in.)	24	24	26	26	26	26
Type	Prop	Prop	Prop	Prop	Prop	Prop
Drive type	Direct	Direct	Direct	Direct	Direct	Direct
Number of speeds	1	1	1	1	1	1
Motor HP each	1/8	1/8	1/3	1/3	1/3	1/3
RPM	790	790	850	850	850	850
Nominal total CFM	2300	2300	4000	4000	4200	4200
Direct Drive Indoor Blower Data						
Fan Size (in.)	11 x 8	11 x 8	11 x 10	11 x 10	11 x 10	11 x 10
Type	Centrifugal	Centrifugal	Centrifugal	Centrifugal	Centrifugal	Centrifugal
Motor HP each	1/2	1/2	1/2	3/4	3/4	1
RPM	1200 Max	1200 Max	1200 Max	1200 Max	1200 Max	1200 Max
Frame size	48	48	48	48	48	48
Filters						
Filter size	A	A	B	B	B	B
Quantity - Size	Field-supplied external filters must be sized so as not to exceed 300 fpm air velocity through disposable filters. For internal filter use, a filter rack kit is available. Consult the instructions supplied with the kit for replacement filter sizes. Filter sizes: A= 20 x 20, B = 20 x 30.					

COMPRESSORS

⚠ CAUTION

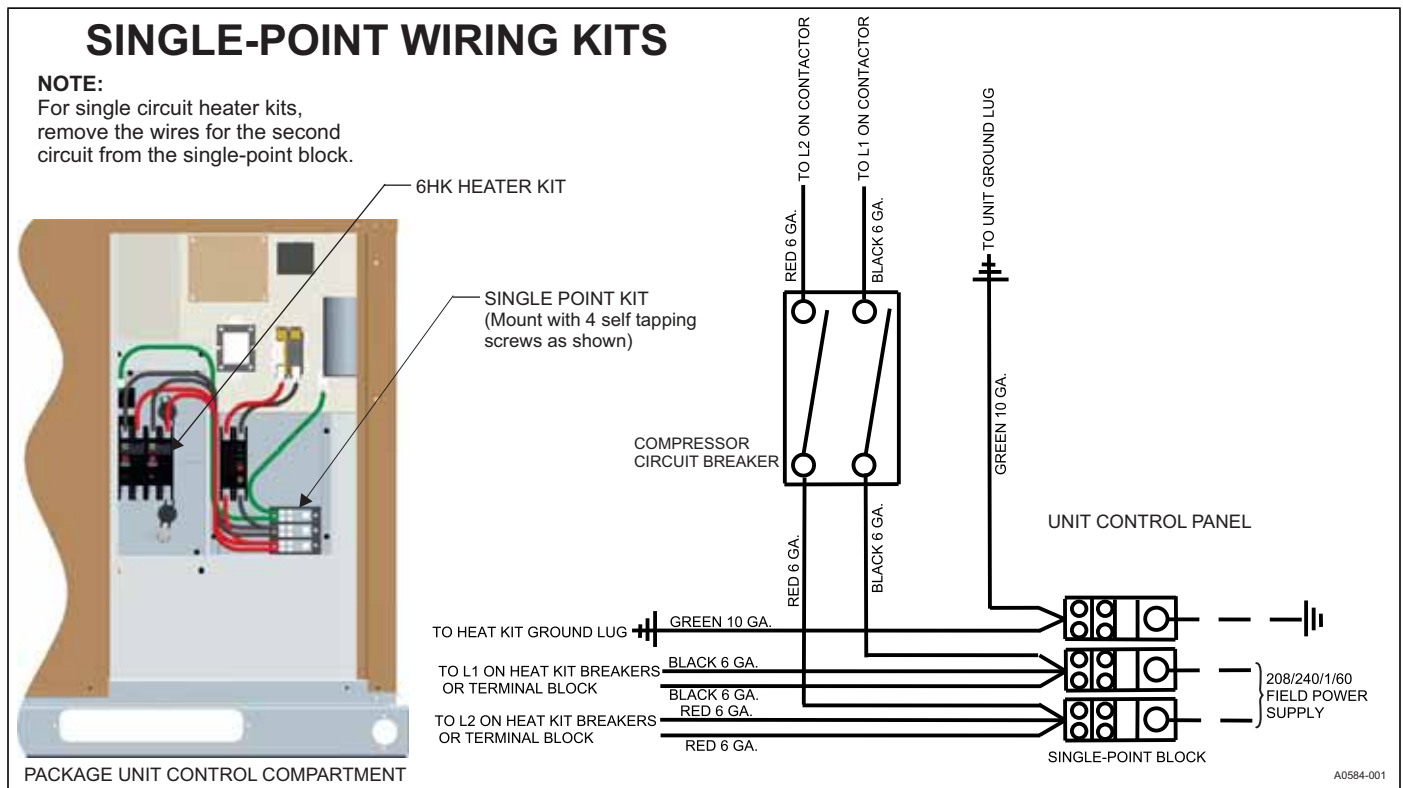
This system uses R-410A Refrigerant which operates at higher pressures than R-22. No other refrigerant may be used in this system.

The compressor used in this product is specifically designed to operate with R-410A refrigerant and cannot be interchanged. Compressors used in PHE6 models contain two internal bypass ports, which enable the compressor to operate at 67% part load capacity.

The compressor uses polyolester (POE oil), Mobile 3MA POE. This oil is extremely hygroscopic, meaning it absorbs water readily. POE oil can absorb 15 times as much water as other oils designed for HCFC and CFC refrigerants. If refrigerant circuit is opened, take all necessary precautions to avoid exposure of the oil to the atmosphere.

⚠ CAUTION

*Do not leave the system open to the atmosphere. Unit damage could occur due to moisture being absorbed by the **POE oil** in the system. This type of oil is highly susceptible to moisture absorption*

POE (polyolester) compressor lubricants are known to cause long-term damage to some synthetic roofing materials.

⚠ CAUTION

Exposure, even if immediately cleaned up, may cause embrittlement (leading to cracking) to occur in one year or more. When performing any service that may risk exposure of compressor oil to the roof, take precautions to protect roofing.

Procedures that risk oil leakage include, but are not limited to, compressor replacement, repairing refrigerant leaks, and replacing refrigerant components such as filter drier, pressure switch, metering device, or coil.

⚠ CAUTION

Do not loosen compressor mounting bolts.

Units are shipped with compressor mountings that are factory-adjusted and ready for operation.

SECTION V: AIRFLOW PERFORMANCE

Table 11: Airflow Performance - Side Duct Application

Model	Jumper Position	External Static Pressure (in. W.C.)										
		0.1	0.2	0.3	0.4	0.5	0.6	0.7	0.8	0.9	1.0	
		SCFM	SCFM	SCFM	SCFM	SCFM	SCFM	SCFM	SCFM	SCFM	SCFM	
PHE6A24	High Cool/Heat	A	961	923	874	822	776	735	682	624	581	552
		B	910	837	780	729	685	631	576	529	495	453
		C	870	761	699	649	605	539	484	449	422	370
		D	799	623	552	475	436	387	338	294	237	192
	Low Cool/Heat	A	902	822	764	713	669	612	557	513	480	437
		B	855	734	669	615	572	509	454	418	385	334
		C	827	678	611	545	504	448	396	356	311	263
		D	675	546	466	404	347	277	205	160	126	80
	Electric Heat	A	1033	1002	963	917	862	826	781	735	678	655
		B	961	923	874	822	776	735	682	624	581	552
		C	910	837	780	729	685	631	576	529	495	453
		D	878	777	715	665	621	558	502	465	437	386
PHE6A30	High Cool/Heat	A	1141	1116	1079	1038	991	946	905	864	820	776
		B	1054	1024	988	944	886	852	809	766	706	684
		C	1023	991	950	903	850	813	767	719	664	640
		D	910	837	780	729	685	631	576	529	495	453
	Low Cool/Heat	A	982	946	899	849	801	761	710	656	609	581
		B	927	867	813	761	717	667	612	561	524	487
		C	870	761	699	649	605	539	484	449	422	370
		D	813	650	582	510	470	417	367	325	274	227
	Electric Heat	A	1108	1082	1045	1003	952	911	869	827	777	742
		B	1002	968	925	876	825	787	738	687	636	611
		C	886	792	731	681	637	576	520	481	451	403
		D	827	678	611	545	504	448	396	356	311	263

Continued on next page. See notes at end of table.

Table 11: Airflow Performance - Side Duct Application (Continued)

Model	Jumper Position		External Static Pressure (in. W.C.)									
			0.1	0.2	0.3	0.4	0.5	0.6	0.7	0.8	0.9	1.0
			SCFM	SCFM	SCFM	SCFM	SCFM	SCFM	SCFM	SCFM	SCFM	SCFM
PHE6B36	High Cool/Heat	A	1345	1318	1271	1222	1172	1108	1035	961	894	841
		B	1264	1211	1170	1115	1056	981	894	826	775	729
		C	1232	1178	1131	1077	1012	929	853	790	738	690
		D	1058	999	931	859	762	694	635	582	523	459
	Low Cool/Heat	A	1153	1095	1036	979	899	810	751	697	643	588
		B	1015	952	884	802	709	646	582	528	467	402
		C	882	805	741	625	556	501	415	359	297	228
		D	805	718	642	523	436	376	294	247	193	118
	Electric Heat	A	1190	1133	1079	1026	953	861	798	742	689	638
		B	1112	1054	991	928	840	760	701	648	591	532
		C	955	886	821	721	642	584	508	453	391	324
		D	856	776	708	591	516	459	375	321	262	191
PHE6B42	High Cool/Heat	A	1555	1518	1494	1459	1414	1360	1318	1261	1220	1162
		B	1473	1435	1406	1368	1320	1264	1220	1164	1119	1060
		C	1374	1333	1298	1255	1204	1145	1100	1044	993	933
		D	1216	1168	1117	1064	1007	942	892	838	775	712
	Low Cool/Heat	A	1233	1186	1137	1085	1029	965	915	861	799	736
		B	1139	1087	1027	968	907	839	785	733	663	598
		C	1025	966	892	823	756	684	625	575	494	427
		D	964	900	816	742	672	596	534	485	398	329
	Electric Heat	A	1441	1407	1373	1325	1279	1232	1182	1108	1042	1039
		B	1327	1286	1242	1192	1143	1081	1024	949	881	834
		C	1187	1136	1084	1028	968	886	827	767	702	657
		D	1087	1031	974	909	832	750	704	653	600	537
PHE6B48	High Cool/Heat	A	1851	1809	1781	1746	1707	1656	1609	1552	1518	1460
		B	1689	1652	1630	1597	1556	1504	1461	1404	1368	1310
		C	1614	1578	1554	1520	1477	1424	1382	1324	1286	1228
		D	1374	1333	1298	1255	1204	1145	1100	1044	993	933
	Low Cool/Heat	A	1473	1435	1406	1368	1320	1264	1220	1164	1119	1060
		B	1374	1333	1298	1255	1204	1145	1100	1044	993	933
		C	1322	1278	1238	1191	1138	1077	1030	975	920	859
		D	1286	1241	1197	1149	1095	1032	984	930	872	810
	Electric Heat	A	1441	1407	1373	1325	1279	1232	1182	1108	1042	1039
		B	1327	1286	1242	1192	1143	1081	1024	949	881	834
		C	1187	1136	1084	1028	968	886	827	767	702	657
		D	1087	1031	974	909	832	750	704	653	600	537
PHE6B60	High Cool/Heat	A	2149	2114	2077	2030	1989	1948	1905	1859	1816	1768
		B	2013	1977	1941	1898	1860	1816	1772	1726	1677	1630
		C	1936	1900	1864	1822	1783	1739	1695	1649	1597	1551
		D	1719	1685	1642	1600	1555	1508	1465	1418	1372	1327
	Low Cool/Heat	A	1629	1591	1546	1502	1455	1409	1362	1315	1266	1220
		B	1558	1516	1469	1423	1375	1329	1280	1232	1181	1135
		C	1453	1406	1355	1305	1255	1207	1153	1100	1047	997
		D	1410	1361	1307	1255	1204	1155	1100	1044	992	938
	Electric Heat	A	1743	1712	1666	1623	1580	1540	1493	1449	1404	1370
		B	1485	1436	1380	1329	1283	1234	1185	1139	1084	1032
		C	1382	1324	1265	1210	1162	1108	1059	1012	952	891
		D	1205	1131	1066	1005	953	892	841	793	724	644

Notes:

Airflow tested with dry coil conditions, without air filters, at 230 V.

Applications above 0.8 in. W.C. external static pressure are not recommended.

Brushless DC high efficiency standard ECM blower motor used for all indoor blower assemblies.

Minimal variations in airflow performance data result from operating at 208 V. Data above can be used in those cases.

Minimal variations in airflow performance data result from using downflow duct applications. Data above can be used in those cases.

Heating applications tested at 0.50 in. W.C. external static pressure, and cooling applications tested at 0.30 in. W.C. external static pressure per standards.

Table 12: Electric Heat Multipliers

Voltage		kW Capacity Multipliers ¹
Nominal	Applied	
240	208	0.75
	230	0.92

1. Electric heaters are rated at nominal voltage. Use this table to determine the electric heat capacity for heaters applied at lower voltages.

Table 13: Recommended Blower Speed for Electric Heat

Model	Heater kW								
	2	5	8	10	13	15	18	20	25
PHE6A24	D (LO)	D (LO)	C (ML)	B (MH)	A (HI)	--	--	--	--
PHE6A30	D (LO)	D (LO)	D (LO)	C (ML)	B (MH)	A (HI)	--	--	--
PHE6B36	D (LO)	D (LO)	D (LO)	C (ML)	B (MH)	A (HI)	--	--	--
PHE6B42	--	D (LO)	D (LO)	D (LO)	D (LO)	C (ML)	B (MH)	A (HI)	--
PHE6B48	--	D (LO)	D (LO)	D (LO)	D (LO)	C (ML)	B (MH)	A (HI)	--
PHE6B60	--	D (LO)	D (LO)	D (LO)	D (LO)	D (LO)	C (ML)	B (MH)	A (HI)

Note: The recommended HEAT speed selections above give approximately a 45 degree temperature rise at 0.3 in. static with 230-V power supply. If lower or higher heating airflow is required, or if duct static or voltage are different than specified, other speed taps can be used.

Table 14: Electric Heat Blower Off Delay

Model ID	Blower Off Delay in Seconds
PHE6A24	0
PHE6A30	60
PHE6B36	60
PHE6B42	110
PHE6B48	110
PHE6B60	110

Table 15: Additional Static Resistance

Size (Tons)	CFM	Wet Indoor Coil	Economizer ¹	Filter/Frame Kit
24 (2.0)	500	0.01	0.00	0.01
	600	0.01	0.00	0.02
	700	0.01	0.00	0.04
	800	0.02	0.01	0.06
	900	0.03	0.01	0.08
	1000	0.04	0.01	0.10
	1100	0.05	0.01	0.13
	1200	0.06	0.02	0.16
30 (2.5)	700	0.01	0.00	0.04
	800	0.02	0.01	0.06
	900	0.03	0.01	0.08
	1000	0.04	0.01	0.10
	1100	0.05	0.01	0.13
	1200	0.06	0.02	0.16
36 (3.0)	700	0.01	0.00	0.04
	800	0.02	0.01	0.06
	900	0.03	0.01	0.08
	1000	0.04	0.01	0.10
	1100	0.05	0.01	0.13
	1200	0.06	0.02	0.16
	1300	0.07	0.03	0.17
	1400	0.08	0.04	0.18
42 (3.5)	1100	0.02	0.02	0.04
	1200	0.03	0.02	0.04
	1300	0.04	0.02	0.05
	1400	0.05	0.03	0.05
	1500	0.06	0.04	0.06
	1600	0.07	0.04	0.07
	1700	0.07	0.04	0.08
	1800	0.08	0.04	0.09
	1900	0.09	0.05	0.10
	2000	0.09	0.05	0.11
48 (4.0)	1100	0.02	0.02	0.04
	1200	0.03	0.02	0.04
	1300	0.04	0.02	0.05
	1400	0.05	0.03	0.05
	1500	0.06	0.04	0.06
	1600	0.07	0.04	0.07
	1700	0.07	0.04	0.08
	1800	0.08	0.04	0.09
	1900	0.09	0.05	0.10
	2000	0.09	0.05	0.11
60 (5.0)	1100	0.02	0.02	0.04
	1200	0.03	0.02	0.04
	1300	0.04	0.02	0.05
	1400	0.05	0.03	0.05
	1500	0.06	0.04	0.06
	1600	0.07	0.04	0.07
	1700	0.07	0.04	0.08
	1800	0.08	0.04	0.09
	1900	0.09	0.05	0.10
	2000	0.09	0.05	0.11

1. The pressure drop through the economizer is greater for 100% outdoor air than for 100% return air. If the resistance of the return air duct is less than 0.25 IWG, the unit delivers less CFM during full economizer operation.

Note: Filter pressure drop based on standard filter media tested at velocities not to exceed 300 ft/min.

SECTION VI: OPERATION

The unit is controlled by a heat pump heating/cooling thermostat.

If an electronic thermostat is used, make sure it has a common connection. DO NOT use a power stealing thermostat.

This unit has a multi-stage compressor, so the unit has two stages of mechanical heat, and two stages of mechanical cooling. The unit may be controlled using a single stage heat/single stage cool (1H/1C) heat pump thermostat, but the second stage cooling or heating is not available unless the unit control is physically wired for full capacity operation. For optimum performance, use a four stage heat/two stage cool (4H/2C) heat pump thermostat. If a 10 kW or smaller heat kit is installed, use a three stage heat/two stage cool (3H/2C) heat pump thermostat.

COOLING SEQUENCE OF OPERATION

A call for a compressor cooling signal from the thermostat is initiated at the Y1 terminal (for OD compressor) and the O terminal (for reversing valve).

The control cycles the compressor and indoor blower to second stage cooling speed anytime a second stage cooling Y2 call is received during a first stage cooling Y1 call. The control does not operate on second stage cooling without a call on the Y2 thermostat input.

- On a call for cooling, the thermostat sends 24 V to Y and O on the defrost control board. The reversing valve solenoid is energized. After the antishort cycle period is complete, the contactor coil M is energized. Power is supplied to the compressor and outdoor fan motor, and the reversing valve is switched to the cooling position. The indoor blower is controlled by the indoor blower control board. It operates on the LOW COOL or HIGH COOL speed based on the 24-VAC input from the defrost control board. If the control receives an O input without a Y input, it energizes the reversing valve only.
- When the demand for cooling has been satisfied, the 24-V Y signal is removed, and the contactor is de-energized. The indoor blower motor continues to run and ramps down after a 60-s delay.

Dehumidification/Humidity Switch Input

This model unit features a built-in de-humidification feature for advanced dehumidification during cooling operation. The unit indoor blower control is designed to work with a humidity control that closes when the humidity is below the set-point. The control is open when the humidity is above the set-point. This humidity control can be referred to as a humidistat or dehumidistat.

To use this feature, the control HUM STAT jumper must be set to YES and a humidistat must be connected from the low voltage R and HUM color coded leads. During cooling operation, if the humidity level is above the humidistat set point, the indoor blower speed is reduced by approximately 15%.

Safety Controls

▲ WARNING

The ability to properly perform maintenance on this equipment requires certain expertise, mechanical skills, tools and equipment. If you do not possess these, do not attempt to perform any maintenance other than those procedures recommended in this Installation Manual. Failure to heed this warning could result in serious injury and possible damage to this equipment.

The control circuit includes the following safety controls:

- High Pressure Switch (HPS)** - The switch protects against excessive discharge pressures and the defrost control locks out compressor operation.
- Loss of Charge Switch (LCS)** - The switch protects against loss of charge due to a leak in the system.

The above pressure switches are specifically designed to operate with R-410A systems. R-22 pressure switches must not be used as replacements for R-410A pressure switches.

Indoor Circulating Blower

When the thermostat calls for FAN, the thermostat terminal G is energized, signaling the indoor blower control board to operate the circulating blower to run continuously. The circulating blower airflow is approximately 63% of the HIGH COOL airflow selected on the indoor blower control board.

If a call for COOL occurs on Y1, the indoor blower runs at the LOW COOL speed based on the COOL jumper setting. If a call for cool is present on Y1+Y2, the indoor blower runs at the HIGH COOL speed based on the COOL jumper setting.

If a call for HEAT occurs on W1 or W1+W2, the circulating blower runs at the heat speed based on the HEAT jumper setting.

When the thermostat ends the call for FAN, the thermostat terminal G is de-energized, and the indoor blower control board stops the circulating blower operation.

Table 16: Indoor Blower Control Fault Codes

Flashes	Fault Condition
LAMP OFF	No Power to control
LAMP ON	Internal control failure
SLOW RED	Control normal operation
RAPID RED	Test Mode
7 RED	Call for heat and cool at the same time
8 RED	Model ID plug not inserted
9 RED	Internal fault self corrected, attempting normal operation

Delay Profiles

The Delay Profiles for each Delay jumper setting are shown in Table 17. The levels shown in the Pre-Run, Short-Run, and Run Periods are a percentage of the fan speed corresponding to the thermostat call. The Post-Run and Off Delay levels are derived from the level of the previous state, not the fan speed corresponding to the thermostat call.

If in Delay Profile B and in the Short-Run Period (82% of capacity), and the thermostat call is removed, this causes the control to enter the Post-Run state. The Post-Run state level for Delay Profile B is 100% of the previous level, so the level during the Post-Run state is 82%.

Table 17: Delay Profile Descriptions

Delay Profile	Period	Cooling		Heat Pump Heating	
		Level%	Time in State (Minutes)	Level%	Time in State (Minutes)
A	Pre-Run	Bypass	Bypass	Bypass	Bypass
	Short-Run	Bypass	Bypass	Bypass	Bypass
	Run	100	No Limit	100	No Limit
	Post-Run*	100	1	100	.5
	Off Delay*	Bypass	Bypass	Bypass	Bypass
B	Pre-Run	50	2	Bypass	Bypass
	Short-Run	82	5	Bypass	Bypass
	Run	100	No Limit	100	No Limit
	Post-Run*	100	1	100	.5
	Off Delay*	Bypass	Bypass	Bypass	Bypass
C	Pre-Run	Bypass	Bypass	Bypass	Bypass
	Short-Run	Bypass	Bypass	Bypass	Bypass
	Run	100	No Limit	100	No Limit
	Post-Run*	100	1	100	.5
	Off Delay*	50	1	Bypass	Bypass
D	Pre-Run	Bypass	Bypass	Bypass	Bypass
	Short-Run	63	1.55	Bypass	Bypass
	Run	100	No Limit	100	No Limit
	Post-Run*	100	1	100	.5
	Off Delay*	63	0.5	Bypass	Bypass

* The Post-Run and Off Delay levels are derived from the level of the previous state, not the fan speed corresponding to the thermostat call.

HEATING SEQUENCE OF OPERATION

- On a call for heating, the thermostat sends 24 V to Y1 or Y1+Y2 on the defrost control board. After the anti-short cycle period is complete, the 24-V signal from Y1 energizes contactor coil M to supply power for the compressor and outdoor fan motor. The indoor blower control operates the indoor blower motor at the LOW COOL speed. If the 24-V signal from Y2 is present, the defrost control board energizes the 2nd stage compressor solenoid and signals the indoor blower control to operate the indoor blower motor at the HIGH COOL speed. The reversing valve remains in the heating position. Indoor blower speeds are selected by the COOL jumper on the indoor blower control board.
- If the heat pump cannot meet the heating demand using mechanical (compressor) heating, the indoor thermostat may energize auxiliary (electric) heating to supplement the mechanical heating if an electric heat kit has been field installed. The room thermostat sends a 24-VAC signal on W1 or W1+W2. The W1 signal is received by the indoor blower control board, which then energizes the HT1 output for electric heat. When a call for mechanical heating and supplemental heating is present, the indoor blower control operates the indoor blower at either the Y1+Y2 or the W1 speed, whichever is higher based on the COOL and HEAT jumper selection.

NOTICE

The W1 must be energized with W2 in order to enable indoor air flow.

- A second stage auxiliary electric heating W2 from the thermostat is to be wired directly to the second stage heat kit input.
- When the heating demand is satisfied, the electric heat is de-energized when the 24-V W signal is removed, and the M contactor is de-energized when the 24-V Y signal is removed. When the fan switch on the thermostat is in the ON position, the indoor blower continues to run. When the fan switch is in the AUTO position, the indoor blower motor ramps down after the blower off delay.
 - Refer to Table 14 for more information.

DEFROST OPERATION

The demand defrost control implements a temperature differential (delta-T) demand defrost algorithm. The heat pump is allowed to operate in the heating mode until the combination of outdoor ambient and outdoor coil temperatures indicates that defrosting is necessary. When coil temperature is below the initiate point for the ambient temperature continuously for 4-1/2 min, the heat pump is put into a defrost cycle. This 4-1/2 min timer eliminates unnecessary defrost cycles caused by refrigeration surges such as those that occur at the start of a heating cycle.

A timed inhibit feature prevents the system from responding to a call for defrost less than 40 min after the initiation of the previous defrost. After the 40-min inhibit time has expired, temperature conditions must call for defrost continuously for 4-1/2 min before a defrost cycle is initiated. A temperature inhibit feature prohibits defrost if the coil temperature is above 40°F.

A forced-defrost feature puts the system into a defrost period every 6 h and 4 min of accumulated compressor run-time to recirculate lubricants, unless the coil temperature is above 40°F and the ambient temperature is above 50°F. All defrost timing occurs only while the compressor is on.

During the defrost mode, the reversing valve is energized, the outdoor fan is de-energized, the compressor is energized in second stage, and the defrost control provides a 24-V signal from terminal W1OUT to energize electric heat stage 1 if the unit is equipped with electric heat.

By selecting LO on the DEFROST HEAT jumper, W1 OUT is energized during defrost. By selecting HI on the DEFROST HEAT jumper, W1 OUT and W2 OUT are energized during defrost.

For troubleshooting purposes, the defrost cycle can be manually initiated by shorting the TEST pins together for 5 s while Y is energized. After removing the short, defrost terminates normally during the TEST mode.

Table 18: Demand Defrost Selection

Unit	Pin Position
024-060	2
024-060	4*

* For extreme environments as necessary only.

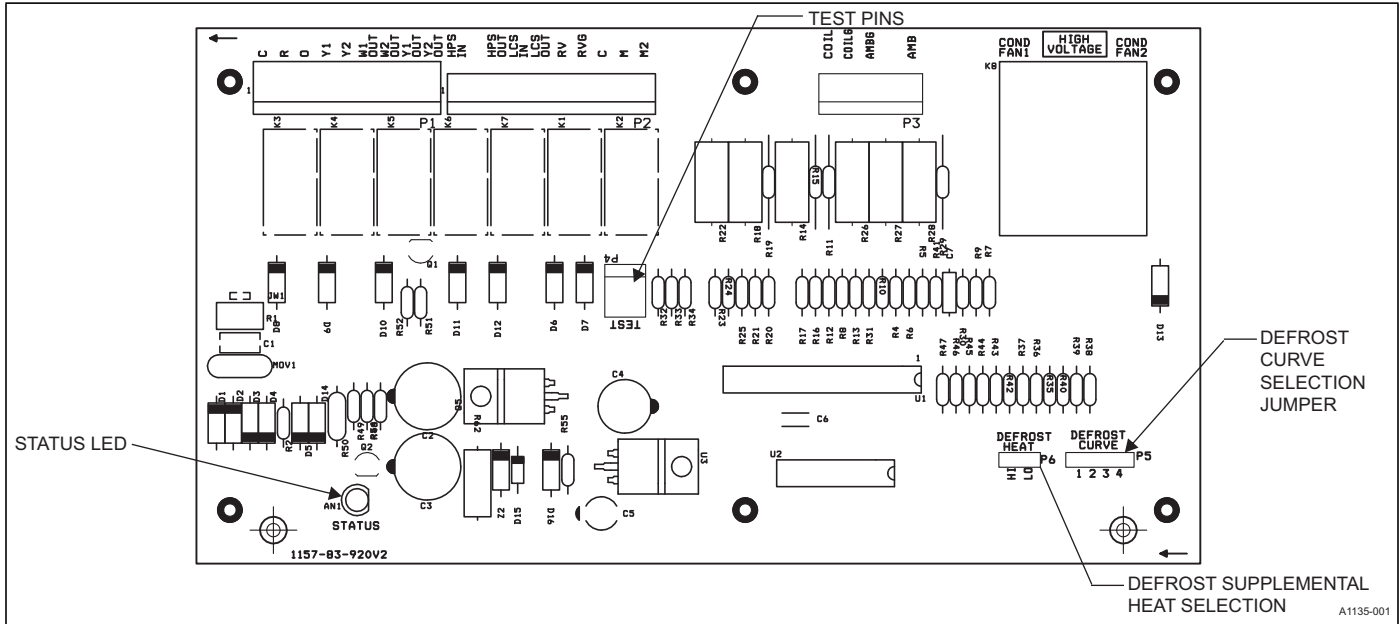

Figure 9: Demand Defrost Control

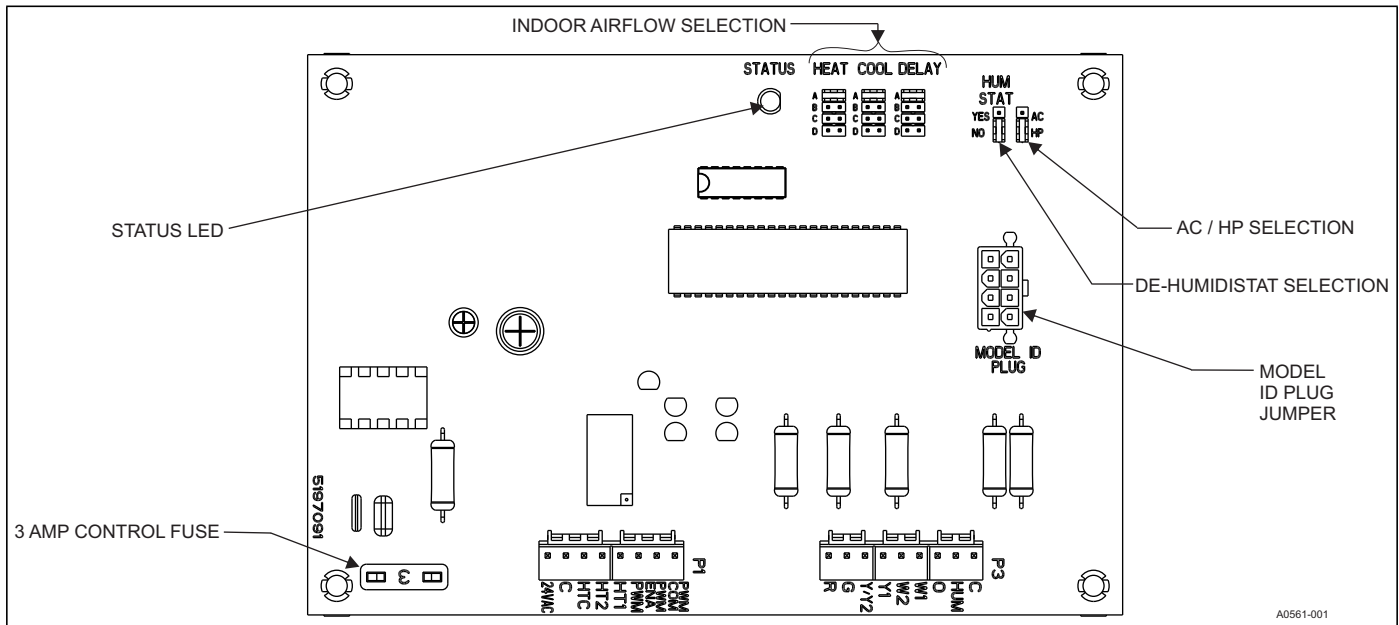

Figure 10: Blower Control

Heat Pump Safety Switch Operation

The unit is equipped with a safety package. The high pressure switch prevents the pressure in the refrigeration system from becoming too high. The loss of charge switch protects against loss of charge due to a leak in the refrigeration system. If either of these safety switches open, the unit is shut off for the 5-min anti-short cycle time. Once this has expired, a 6-h elapsed run timer begins. If a second opening of a safety switch occurs during this 6-h period, the compressor is locked out.

To reset the lockout function:

1. Remove power from the control's thermostat 1st stage (Y) input for more than 2 s.
2. Remove power from R for more than 2 s.
3. Short the TEST pins together for more than 2 s while Y is energized.
4. Short the TEST pins together for more than 5 s while Y is de-energized.

Table 19: Test Pins

Test Pin Shorted	With Y Call	Without Y Call
Greater than 2 s	Bypass ASCD	Show error codes
Greater than 5 s	Forced defrost	Clear error codes

Demand Defrost Fault Code Display

The control provides fault codes using the Status LED display. Table 20 describes the LED displays for fault codes. On the LED display, the control displays a single fault code only. The control displays the fault code on the LED display repeatedly with a 2-s off period between repetitions of the fault code. If multiple fault codes are present at the same time, the LED displays only the highest priority fault. The other active faults can be accessed using the LAST ERROR button on the control board.

Table 20 shows the LED display representation for specified faults. For instance, a red LED display of 10 flashes indicates a control failure.

When any fault code is present, the control does not display the current status code for the stage of operation.

Table 20: Demand Defrost Fault Codes

Description	STATUS LED
High-pressure switch fault (not in lockout yet)	2 Flashes
System in high-pressure switch lockout (last mode of operation was normal compressor)	3 Flashes
System in high-pressure switch lockout (last mode of operation was defrost)	4 Flashes
System in loss of charge switch lockout (last mode of operation was normal compressor)	5 Flashes
Low Voltage (less than 19.2 VAC) preventing further relay outputs for greater than 2 s	6 Flashes
Low Voltage (less than 16 VAC) stopped current relay outputs for greater than 2 s	7 Flashes
Liquid Line sensor failure (Open or Shorted) – Comp Allowed/Lockout	8 Flashes
Ambient sensor failure (Open or Shorted) – Comp Allowed (if coil is > 40°F)/Lockout	9 Flashes
Control Failure	10 Flashes

Note: If an ambient sensor failure is present, the control uses the coil sensor to determine if the compressor continues to operate or enters a lockout state during compressor heating. The coil temperature determines if a lockout state occurs. When the coil temperature drops below a predetermined range, the control does not allow compressor heating operation. If the coil temperature is above the predetermined range, the control allows compressor heating operation. During cooling mode, if the ambient sensor fails, the coil temperature has no effect on compressor operation.

Electric Heat Limit Switch Operation

The 6HK single phase heat kits utilize a normally closed line voltage limit switch and a normally closed fusible link. If the fusible link opens, it must be replaced with the appropriate OEM part and the cause must be investigated and corrected.

Table 21: Thermostat Signals

Signal	State	Board Function
G	ON	Indoor blower instant on
	OFF	Indoor blower off after 60-s delay
W	ON	Indoor blower instant on
		Electric heat stages on (if so equipped)
	OFF	Indoor blower off after off delay
G and W	ON	Indoor blower instant on in heating speed
		Electric heat stages on (if so equipped)
	W OFF	Indoor blower switches to continuous fan speed
G and Y	ON	Outdoor fan instant on
		Indoor blower instant on in cooling speed
		Compressor on (after any anti-short cycle delay)
		System operates in heat pump heating mode
	Y OFF	Compressor instant off
		Outdoor fan instant off
		Indoor blower switches to continuous fan speed
	G and Y OFF	Compressor instant off
		Indoor blower off after 60-s delay
G and Y and O	ON	Outdoor fan instant on
		Indoor blower instant on in cooling speed
		Compressor on (after any anti-short cycle delay)
		Reversing valve energized
	Y and O OFF	Compressor instant off
		Outdoor fan instant off
		Indoor blower switches to continuous fan speed
	G and Y and O OFF	Compressor instant off
		Outdoor fan instant off
		Reversing valve off
		Per Delay Profiles Paragraph and Table 17

STARTUP

1. Check the electrical supply voltage being supplied. Be sure that it is within the specified range on the unit data plate.
2. Make sure all electrical connections are tight.
3. If unit is connected to 208-V supply power, the control transformer must be wired accordingly.
4. Turn unit electrical power on.
5. Set the room thermostat to COOL mode and lower the required temperature setting lower than the room temperature to create a call for cooling.
6. Measure the total system duct static and set the blower motor cooling speed appropriately per airflow performance tables.
7. Make sure all units panels are in place and secured, and that an air filter is installed.

EXTERNAL STATIC PRESSURE SETUP

To measure external static pressure:

1. Measure the supply air static pressure and record this positive number.

2. Measure the return air static pressure and record this negative number.
3. Treat the negative number as a positive and add the two numbers together. This is total system static.

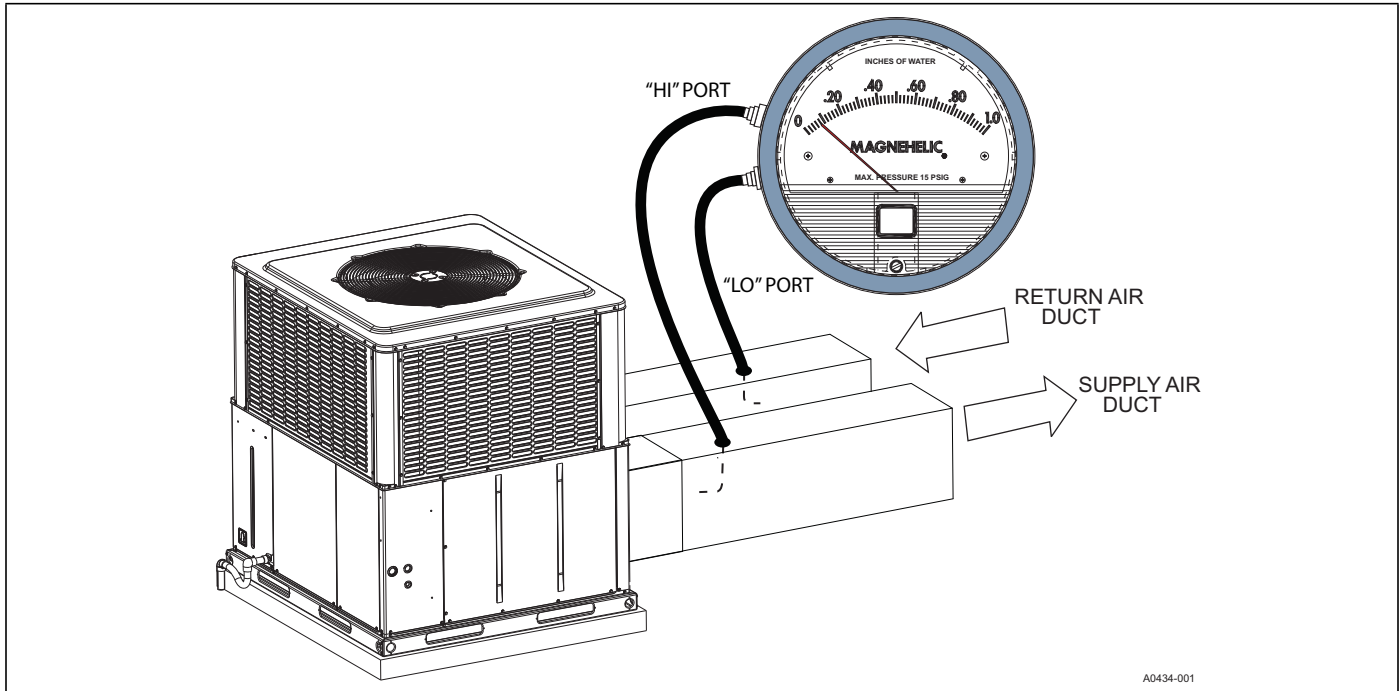

Figure 11: Measuring External Static Pressure

SECTION VII: MAINTENANCE

NORMAL MAINTENANCE

⚠ WARNING

Prior to any of the following maintenance procedures, shut off all power to the unit, to avoid personal injury.

Periodic maintenance consists of changing or cleaning filters and general cleaning of the outdoor coil.

FILTERS - Inspect once a month. Replace Disposable or clean Permanent Type as necessary. DO NOT replace Permanent Type with Disposable.

MOTORS - Indoor and outdoor fan motors are permanently lubricated and require no maintenance.

⚠ CAUTION

Exercise care when cleaning the coil so that the coil fins are not damaged. DO NOT use a pressure washer as coil fin damage will occur. Do not permit the hot outdoor air discharge to be obstructed by overhanging structures or shrubs.

OUTDOOR COIL - Dirt should not be allowed to accumulate on the outdoor coil surface or other parts in the air circuit. Cleaning should be as often as necessary to keep the coil clean. If water is used to clean the coil, be sure that the power to the unit is shut off before cleaning.

TROUBLESHOOTING

⚠ WARNING

Troubleshooting of components necessarily requires opening the electrical control box with the power connected to the unit. Use extreme care when working with live circuit! Check the unit nameplate for the correct range before making any connections with line terminals.

⚠ CAUTION

The wire number or color and terminal designations referred to may vary. Check the wiring label inside the control box access panel for the correct wiring.

SECTION VIII: TYPICAL WIRING DIAGRAMS

2 STAGE HEAT PUMP WITH OR WITHOUT ELECTRIC HEAT - 208/230-1-60 CONNECTION WIRING DIAGRAM

CAUTION
OPEN ALL DISCONNECTS BEFORE SERVICING THIS UNIT.

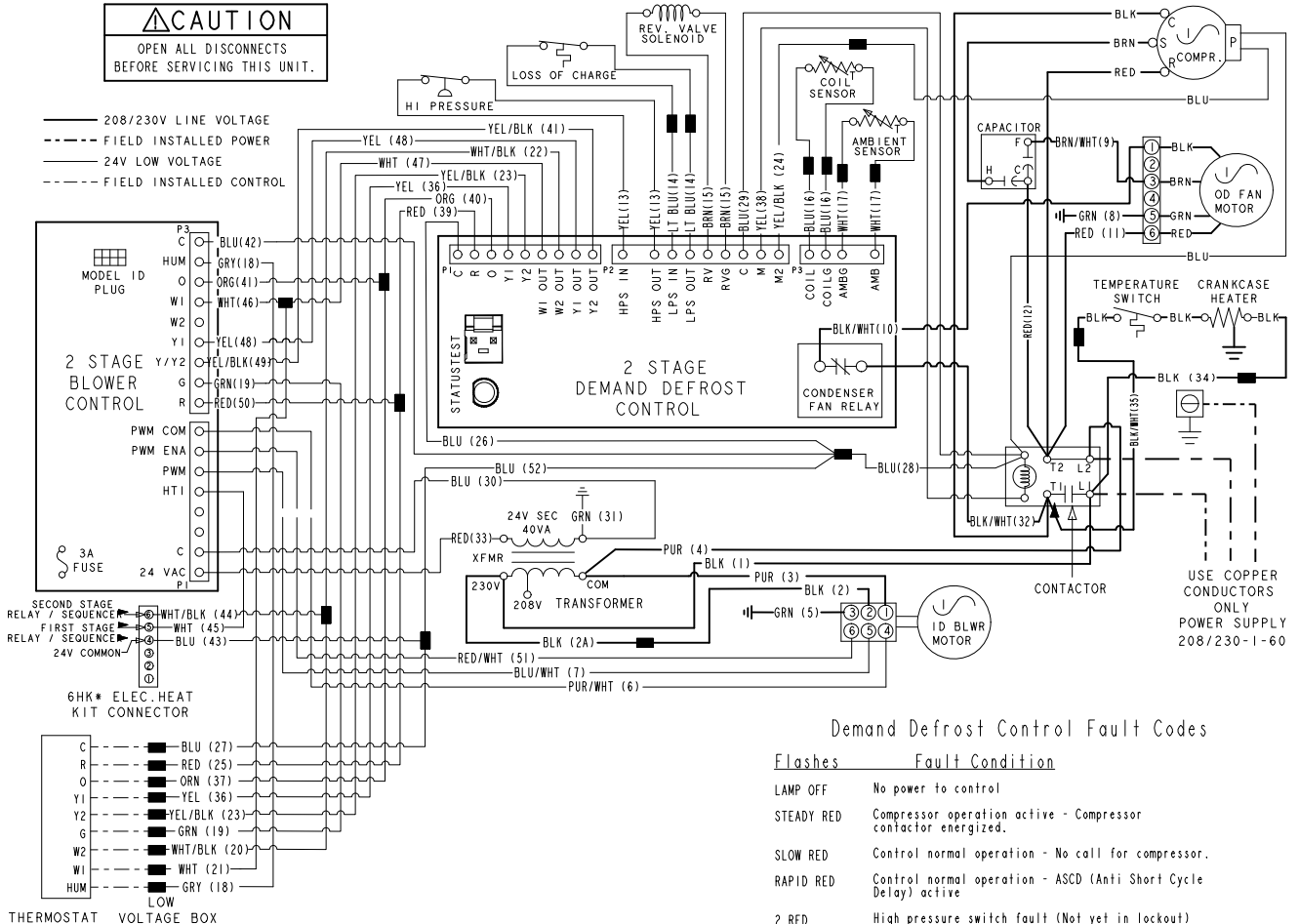

Notes:

1. ALL FIELD WIRING TO BE ACCOMPLISHED FOLLOWING CITY, LOCAL, AND/OR NATIONAL CODES IN EFFECT AT THE TIME OF UNIT INSTALLATION.
2. CAUTION: LABEL ALL WIRES PRIOR TO DISCONNECTION WHEN SERVICING CONTROLS. WIRING ERRORS CAN CAUSE IMPROPER AND DANGEROUS OPERATION. IF ANY OF THE WIRING AS SUPPLIED WITH UNIT MUST BE REMOVED, IT MUST BE REPLACED WITH TYPE 105 C 600 VOLT WIRE OR EQUIVALENT AND CLEARLY RENUMBERED FOR IDENTIFICATION. VERIFY PROPER OPERATION AFTER SERVICING.
3. FACTORY WIRED FOR 230 VOLT SUPPLY POWER. FOR 208 VOLT SUPPLY POWER, MOVE BLACK WIRES FROM THE 230 VOLT TAP TO THE 208 VOLT TAP ON THE TRANSFORMER.
4. MOTORS ARE INHERENTLY PROTECTED.
5. SEE UNIT NAMEPLATE FOR MAXIMUM FUSE AND/OR CIRCUIT BREAKER SIZE AND MINIMUM CIRCUIT AMPACITY.

Flashes	Fault Condition
LAMP OFF	No power to control
LAMP ON	Internal control failure
SLOW RED	Control normal operation
RAPID RED	Test mode
7 RED	Call for heat and cool at the same time
8 RED	Model ID plug not inserted
9 RED	Internal fault self corrected, attempting normal operation

5245103-UWD-B-0918

Figure 12: Connection Wiring Diagram

2 STAGE HEAT PUMP WITH OR WITHOUT ELECTRIC HEAT - 208/230-1-60 LADDER WIRING DIAGRAM

CAUTION
OPEN ALL DISCONNECTS
BEFORE SERVICING THIS UNIT.

Demand Defrost Control Fault Codes

Flashes	Fault Condition
LAMP OFF	No power to control
STEADY RED	Compressor operation active - Compressor contactor energized.
SLOW RED	Control normal operation - No call for compressor.
RAPID RED	Control normal operation - ASCD (Anti Short Cycle Delay) active
2 RED	High pressure switch fault (Not yet in lockout)
3 RED	System in high pressure switch lockout (Last mode of operation was normal compressor)
4 RED	System in high pressure switch lockout (Last mode of operation was defrost)
5 RED	System in low pressure switch lockout (Last mode of operation was normal compressor)
6 RED	Low Voltage (<19.2 VAC) preventing further relay outputs for >2 seconds
7 RED	Low Voltage (<16 VAC) stopped current relay outputs for >2 seconds
8 RED	Liquid line sensor failure (Open or Shorted) - Comp Allowed/Lockout
9 RED	Ambient sensor failure (Open or Shorted) - Comp Allowed (if coil is >40°F)/Lockout
10 RED	Control Failure

Notes:

- ALL FIELD WIRING TO BE ACCOMPLISHED FOLLOWING CITY, LOCAL, AND/OR NATIONAL CODES IN EFFECT AT THE TIME OF UNIT INSTALLATION.
- CAUTION: LABEL ALL WIRES PRIOR TO DISCONNECTION WHEN SERVICING CONTROLS. WIRING ERRORS CAN CAUSE IMPROPER AND DANGEROUS OPERATION. IF ANY OF THE WIRING AS SUPPLIED WITH UNIT MUST BE REMOVED, IT MUST BE REPLACED WITH TYPE 105 C 600 VOLT WIRE OR EQUIVALENT AND CLEARLY RENUMBERED FOR IDENTIFICATION. VERIFY PROPER OPERATION AFTER SERVICING.
- FACTORY WIRED FOR 230 VOLT SUPPLY POWER. FOR 208 VOLT SUPPLY POWER, MOVE BLACK WIRES FROM THE 230 VOLT TAP TO THE 208 VOLT TAP ON THE TRANSFORMER.
- MOTORS ARE INHERENTLY PROTECTED.
- SEE UNIT NAMEPLATE FOR MAXIMUM FUSE AND/OR CIRCUIT BREAKER SIZE AND MINIMUM CIRCUIT AMPACITY.

Blower Control Fault Codes

Flashes	Fault Condition
LAMP OFF	No power to control
LAMP ON	Internal control failure
SLOW RED	Control normal operation
RAPID RED	Test mode
7 RED	Call for heat and cool at the same time
8 RED	Model ID plug not inserted
9 RED	Internal fault self corrected, attempting normal operation

208/230V LINE VOLTAGE
 FIELD INSTALLED POWER
 24V LOW VOLTAGE
 FIELD INSTALLED CONTROL

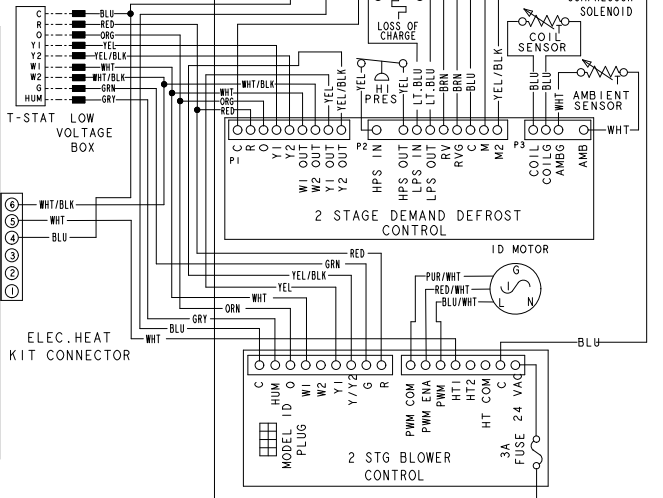
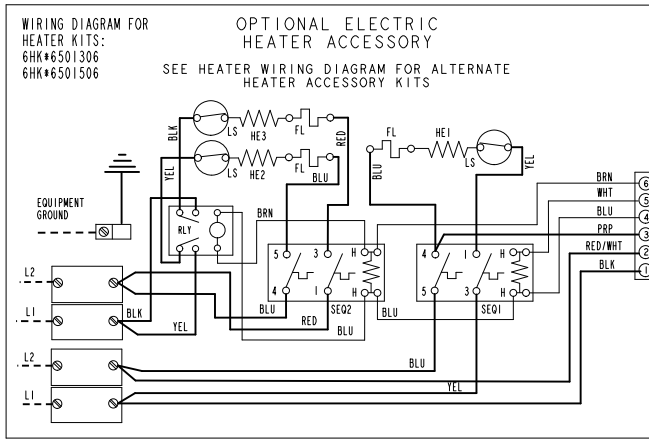
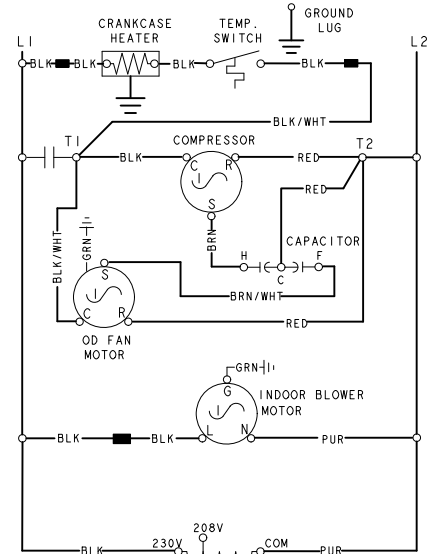

5245103-UWD-B-0918

Figure 13: Ladder Wiring Diagram

R-410A QUICK REFERENCE GUIDE

Refer to Installation Instructions for specific installation requirements

- R-410A refrigerant operates at 50 - 70 percent higher pressures than R-22. Be sure that servicing equipment and replacement components are designed to operate with R-410A.
- R-410A refrigerant cylinders are rose colored.
- Recovery cylinder service pressure rating must be 400 psig, DOT 4BA400, or DOT BW400.
- Recovery equipment must be rated for R-410A.
- **DO NOT** use R-410A service equipment on R-22 systems. All hoses, gages, recovery cylinders, charging cylinders and recovery equipment must be dedicated for use on R-410A systems only.
- Manifold sets must be at least 700 psig high side, and 180 psig low side, with 550 psig retard.
- All hoses must have a service pressure rating of 800 psig.
- Leak detectors must be designed to detect HFC refrigerants.
- Systems must be charged with liquid refrigerant. Use a commercial type metering device in the manifold hose.
- R-410A can only be used with POE type oils.
- POE type oils rapidly absorb moisture from the atmosphere.
- Vacuum pumps will **not** remove moisture from R-410A refrigerant oils.
- **Do not** use liquid line driers with a rated working pressure rating less than 600 psig.
- **Do not** install suction line driers in the liquid line.
- A liquid line drier is required on every unit.
- **Do not** use a R-22 TXV. If a TXV is to be used, it must be a R-410A TXV.
- Never open system to atmosphere when under a vacuum.
- If system must be opened for service, evacuate system then break the vacuum with dry nitrogen and replace all filter driers.

Figure 14: R-410A Quick Reference Guide

NOTES

SECTION IX: START UP SHEET

Residential Package Unit Heat Pump
with Electric Heat Start-Up Sheet

Proper start-up is critical to customer comfort and equipment longevity

Start-Up Date Company Name Start-Up Technician

Owner Information

Name Address Daytime Phone
City State or Province Zip or Postal Code

Equipment Data

Unit Model # Unit Serial #

General Information (Check all that apply)

<input type="radio"/> Residential	<input type="radio"/> New Construction	<input type="radio"/> Roof level	<input type="radio"/> Down flow
<input type="radio"/> Commercial	<input type="radio"/> Retrofit	<input type="radio"/> Grade level	<input type="radio"/> Side flow

Unit Location and Connections (Check all that apply)

Unit is level and installed on: Slab Roof curb Duct connections are complete: Supply Return
 Condensate drain properly connected per the installation instructions Condensate trap has been primed with water

Filters

Filters installed Number of filters Filter size Filter located inside Filter located outside

Additional Kits & Accessories Installed (Check all that apply)

Refrigerant safety kit Low ambient kit Anti-recycle timer Crank case heater Filter frame kit
 Transformer kit Economizer Roof curb kit Burglar bar kit Hail guard kit
 Manual fresh air damper kit Motorized fresh air damper kit

Electrical Connections & Inspection (Check all that apply)

Single phase Three phase 208 volts AC 230 volt AC 460 volts AC 575 volts AC
 Inspect wires and electrical connections Transformer wired properly for primary supply voltage Ground connected
 Low voltage present at control board "R & C" Measured voltage "R" and "C" outdoor unit control board
 Line voltage present at disconnect Measured voltage "L1 to L2" "L2 to L3" "L1 to L3"
Compressor amperes "L1" "L2" "L3" Total amperes "L1" "L2" "L3"
 Single stage compressor Two stage compressor

Air Flow Setup

Blower Type & Set-Up	<input type="radio"/> Variable Speed	COOL <input type="radio"/> A <input type="radio"/> B <input type="radio"/> C <input type="radio"/> D			
		ADJUST <input type="radio"/> A <input type="radio"/> B <input type="radio"/> C <input type="radio"/> D			
		DELAY <input type="radio"/> A <input type="radio"/> B <input type="radio"/> C <input type="radio"/> D			
		HEAT <input type="radio"/> A <input type="radio"/> B <input type="radio"/> C <input type="radio"/> D			
	<input type="radio"/> Standard ECM	<input type="radio"/> 1 <input type="radio"/> 2 <input type="radio"/> 3 <input type="radio"/> 4 <input type="radio"/> 5			
<input type="radio"/> PSC	<input type="radio"/> Low <input type="radio"/> Medium Low <input type="radio"/> Medium <input type="radio"/> Medium High <input type="radio"/> High				
Supply static (inches of water column)	<input type="text"/>	Supply air dry bulb temperature	<input type="text"/>	Outside air dry bulb temperature	<input type="text"/>
Return static (inches of water column)	<input type="text"/>	Return air dry bulb temperature	<input type="text"/>	Return air wet bulb temperature	<input type="text"/>
Total external static pressure	<input type="text"/>	Temperature drop	<input type="text"/>	Supply air wet bulb temperature	<input type="text"/>

Refrigerant Charge and Metering Device

<input type="radio"/> R-410A <input type="radio"/> R-22	Data plate - lbs / Oz	<input type="text"/>	Suction line temperature	<input type="text"/>	Discharge pressure	<input type="text"/>
<input type="radio"/> TXV <input type="radio"/> Fixed Orifice	Discharge line temperature	<input type="text"/>	Suction pressure	<input type="text"/>	Liquid line temperature	<input type="text"/>
TXV# / Orifice size			<input type="text"/>	Superheat	<input type="text"/>	Subcooling

Electric Heat (Supplemental and Emergency Heat)

Electric heat kit - Model number		<input type="text"/>	Serial number		<input type="text"/>	Rated KW	<input type="text"/>
<input type="radio"/> Single Phase	Measured Amperage	Heater 1	<input type="text"/>	Heater 2	<input type="text"/>	Heater 3	<input type="text"/>
<input type="radio"/> Three Phase		Heater 4	<input type="text"/>	Heater 5	<input type="text"/>	Heater 6	<input type="text"/>
Number of elements	Measured Voltage	Heater 1	<input type="text"/>	Heater 2	<input type="text"/>	Heater 3	<input type="text"/>
		Heater 4	<input type="text"/>	Heater 5	<input type="text"/>	Heater 6	<input type="text"/>
Heating return air dry bulb temperature	<input type="text"/>	Heating supply air dry bulb temperature	<input type="text"/>	Air temperature rise		<input type="text"/>	

Clean Up Job Site

<input type="checkbox"/> Job site has been cleaned, indoor and outdoor debris removed from job site
<input type="checkbox"/> Tools have been removed from unit
<input type="checkbox"/> All panels have been installed

Unit Operation and Cycle Test

<input type="checkbox"/> Operate the unit through continuous fan cycles from the thermostat, noting and correcting any problems
<input type="checkbox"/> Operate the unit through cooling cycles from the thermostat, noting and correcting any problems
<input type="checkbox"/> Operate the unit through mechanical heating cycles from the thermostat, noting and correcting any problems
<input type="checkbox"/> Operate the unit through emergency heating cycles from the thermostat, noting and correcting any problems

Owner Education

<input type="checkbox"/> Provide owner with the owner's manual
<input type="checkbox"/> Explain operation of system to equipment owner
<input type="checkbox"/> Explain thermostat use and programming (if applicable) to owner
<input type="checkbox"/> Explain the importance of regular filter replacement and equipment maintenance

Comments and Additional Job Details