

TECHNICAL GUIDE

**SINGLE PACKAGE
AIR CONDITIONER/ELECTRIC HEAT
16 SEER - R-410A - 208/230 V - 1 PHASE
2 TO 5 NOMINAL TONS
MODELS: PCE6*24 TO 60**



Due to continuous product improvement, specifications are subject to change without notice.

Visit us on the web at

www.simplygettingthejobdone.com

Additional rating information can be found at

www.ahrirectory.org

WARRANTY SUMMARY*

Extended 10-year limited parts and compressor warranty.

*Extended warranty requires online registration within 90 days of purchase for replacement or closing for new home purchase. See the limited warranty certificate in the *User's Information Manual* for details.

DESCRIPTION

These packaged cooling/heating air conditioners are designed for outdoor installation. Only utility and duct connections are required at the point of installation.

FEATURES

- **Operating Efficiency** - All PCE6 air conditioner models are rated at 16.0 SEER for cooling operation. All PCE6 models utilize a multi-stage compressor for maximum comfort and efficiency.
- **On Site Flexibility** - All model sizes use a compact design cabinet in one of two footprints. This provides installer flexibility for placing the proper capacity unit on curbs or pads with the smallest footprint after the internal load has been determined. Field convertible duct connections from side shot to down shot allow the installer to have greater flexibility with less inventory.
- **Lower Installation Cost** - Installation time and costs are reduced by easy power and control wiring connections. The small base dimension means less space is required on the ground or roof. All units are completely wired, charged with R-410A, and tested prior to shipment. Test stations using a state-of-the-art computerized process system are used to ensure product quality. Refrigerant charge and component part numbers are verified using computers during assembly. Vital run test statistics such as system pressure, motor currents, air velocity and temperature, unit vibration, and gas system safeties are monitored and recorded by the system to ensure unit performance. Equal size side supply and return duct connections allow easy connection of ducts to match low crawl spaces without transition pieces.
- **Utility Connections Made Easy** - Electric utility access provided through the bottom or the side of the unit. Utility connections can be made quickly and with a minimum amount of field labor. A field supplied and field installed electrical disconnect switch must be installed.
- **Convertible Airflow Design** - The bottom duct openings are covered when they leave the factory, ready to be used for a side supply/side return application. If a bottom supply/bottom return application is required, remove the two panels from the bottom of the unit and place them in the side supply/side return duct openings. No panel cutting is required and no accessory panel is necessary. Convertible airflow design allows maximum field flexibility and minimum inventory.
- **Condensate Pan** - A corrosion-resistant, long-lasting, water-tight pan is positioned below the indoor coil to collect and drain all condensate, preventing build-up of stagnant condensate. The condensate pan conforms to ASHRAE 62-89 standards (Ventilation for Acceptable Indoor Air Quality).
- **Condensate Drain** - The 3/4-in. NPT female connection is rigidly mounted to ensure proper fit and leak tight seal.

Continued on next page.

- **Durable Finish** - The cabinet is made of G90 galvanized steel with a powder paint coating for appearance and protection. The pre-treated galvanized steel provides a better paint-to-steel bond, which resists corrosion and rust creep. Powder paint finish ensures less fading when exposed to sunlight, and provides superior corrosion resistance (1,000 hour salt spray tested).
- **Full Perimeter Base Rails** - The easily removable base rails provide a solid foundation for the entire unit and protect the unit during shipment. The rails provide forklift access from all sides, and rigging holes are also provided so that an overhead crane can be used to place the units on a roof. On applications where the unit is placed on a pad, the base keeps the unit off the pad to deter corrosion. On applications where height is limited, the base rails can be removed by removing two screws in each corner.
- **Attractive Appearance** - A single-piece top cover containing a top-discharge outdoor fan arrangement requires less square footage on installation and provides a wider variety of installations. The one-piece design adds greater water integrity. Rounded corners with water drip edges add to the attractive appearance.
- **Top Discharge** - The top-discharge outdoor fan does not disrupt neighboring areas or dry out vegetation surrounding the unit. The warm air from the top mounted fan is blown up and away from the structure and any landscaping.
- **Outdoor Coil Grille** - All models utilize a stamped slotted design that provides superior impact protection against small objects during transit and after installation.
- **Low Operating Sound Level** - The upward airflow carries the normal operating noise up and away from the living area. The rigid top panel effectively isolates noise. Isolator mounted compressor and the rippled fins of the outdoor coil muffle the normal fan motor and compressor operating sounds. The unique formed base pan also aids in sound attenuation with its structural design.
- **Fan System** - All models operate over a wide range of design conditions with an enhanced ECM indoor blower motor. These units easily match all types of applications and provide greater on-site flexibility to match comfort requirements. The cooling speed is factory set and can be field adjusted to a second speed. The heating speed is factory set to maintain mid point rise at the units' heating input, but can be field adjusted. This allows for maximum comfort conditions.
- **Dehumidification/Humidity Switch Input** - This model unit features a built-in dehumidification feature for advanced dehumidification during cooling operation. The unit indoor blower control is designed to work with a humidity control that closes when the humidity is below the setpoint. The control is open when the humidity is above the setpoint. This humidity control can be referred to as a humidistat or dehumidistat.
- **Simple Control Circuit** - Field thermostat wiring connects to color-coded leads using twist on wire connections. Cooling controls use contactor and relays for simple application and troubleshooting. MATE-N-LOK® plug connectors are used. Enhanced ECM indoor blower control is managed by a multi-stage indoor blower control board that includes field adjustable speed tap jumpers for maximum flexibility and product application. The electrical control box is not located in the compressor compartment. The controls are mounted to allow the separate access panel to be removed for trouble shooting and maintenance without affecting the normal system operating pressures. All wiring internal to the unit is color/number coded.
- **Protected Compressor** - The compressor is internally protected against high pressure and temperature. This is accomplished by the simultaneous operation of scroll bypass and a temperature sensor, which protects the compressor if undesirable operating conditions occur. The crankcase heater ensures lubrication of the compressor at start-up by mitigating the impact of refrigerant migration and condensation when the system is off, keeping the refrigerant at a temperature higher than the coldest part of the system.
- **Pressure Switches** - A high pressure switch is standard in all units. It is an automatic reset switch. When discharge pressure reaches 650 psi, the compressor de-energizes until pressure reaches 450 psi.
- **Exclusive Coil Design** - The grooved copper tubes and enhanced aluminum fin construction of the outdoor coils improve heat transfer for maximum efficiency and durability. Indoor tube and fin coils have all aluminum construction for reliability and efficient heat transfer.
- **Electric Heat** - All electric heat models use 6HK electric heat kits, which are available in 208/230-1-60 from 2 kW to 25 kW. All kits are stageable above 10 kW. Single-phase single-point field wiring kits are available for all applications except 25 kW.
- **Low Maintenance** - Long life, permanently lubricated indoor blower motor bearings and outdoor fan motor bearings need no annual maintenance, adding greater reliability to the unit. Slide-out blower assembly and indoor coil assembly can be easily removed for cleaning.
- **Easy Service Access** - Individual access panels provide access to all major components, for example, compressors, indoor coils, blowers, controls/electric heat kits, and filters, making servicing easy. Removing these panels allows easy removal of components such as the blower assembly for maintenance and troubleshooting.
- **Replacement Parts** - The installer requires no special training to replace any of the components of these units and the number of new components has been reduced to minimize the inventory of unique parts.
- **Loss of Charge Switch** - All models include a loss of charge switch to provide safe shutdown of compressor.

Note: To use this feature, the control HUM STAT jumper must be set to YES and a humidistat must be connected from the low-voltage R and HUM color-coded leads. During cooling operation, if the humidity level is above the humidistat setpoint, the indoor blower speed is reduced by approximately 15%.

NOMENCLATURE

PCE	6	A	24		2		4	A
1	2	3	4	5	6	7	8	9
1. Model Family PCG - packaged A/C with gas heat PHG - packaged heat pump with gas heat PCE - packaged A/C with electric heat PHE - packaged heat pump with electric heat 2. Nominal Cooling Efficiency 4 = 14 SEER, 6 = 16 SEER 3. Cabinet Size A = small 35.75 x 51.25, B = large 45.75 x 51.25 4. Nominal Air Conditioning Cooling Capacity BTU/h x 1000 24 = 24,000 BTU/h, 30 = 30,000 BTU/h Example: PCE6A2424A is a packaged A/C with electric heat, 16 SEER, small cabinet, 2 ton, 208/230 V, single phase model, fourth generation, original release.					5. Gas Heating Input BTU/h x 1000 050 = 50,000 BTU/h input, blank = electric heat 6. Voltage-Phase-Frequency 2 = 208/230-1-60, 3 = 208/230-3-60, 4 = 460-3-60 7. NOx Approval X = Low NOx, blank = not Low NOx 8. Generation Level 1 = first generation, 2 = second generation 9. Revision Level A = original release, B = second release			

COMPONENT LOCATION

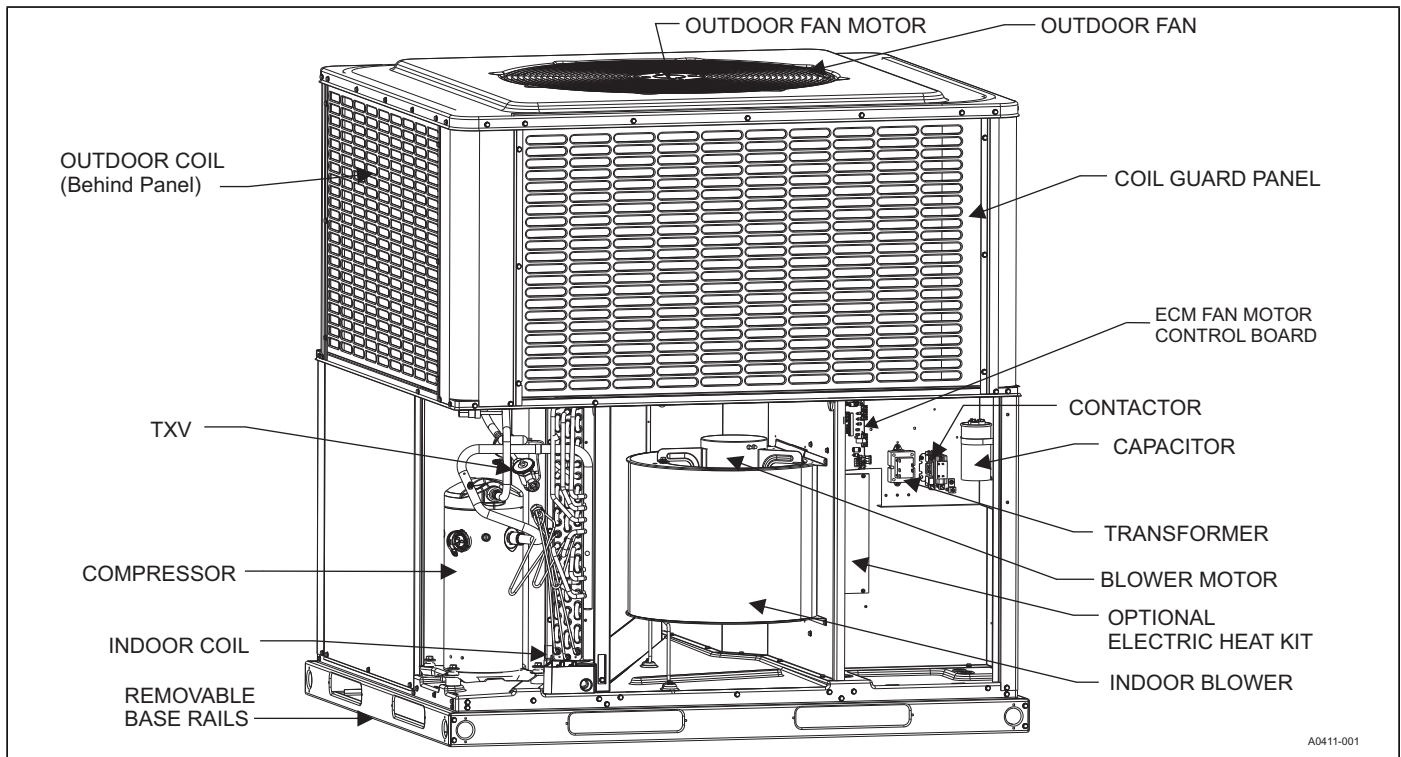

UNIT LIMITATIONS

Model	Unit Voltage	Unit Limitations		
		Applied Voltage		Outdoor DB Temperature Maximum (°F)
		Minimum	Maximum	
All Models	208/230-1-60	187	252	125

APPLICATIONS AND ACCESSORIES

Application Limitations				
Packaged Equipment Series	Air Temperature at Outdoor Coil (°F)		Air Temperature at Indoor Coil (°F)	
	Minimum	Maximum	Minimum	Maximum
	DB Cool	DB Cool	WB Cool	WB Cool
16 SEER AC	55	125	57	72

- **Anchor Bracket Kit (S1-1HK0601)** - This kit firmly anchors PCG, PCE, PHE, and PHG packaged units to a pad or support structure. When correctly installed, the kit is approved for ground-mounted or roof-mounted applications, wind load certified, and listed with the State of Florida. See <https://floridabuilding.org> for this listing.
- **Economizer for Downflow Applications (S1-2EE04710024, S1-2EE04710124)** - Modulating integrated economizer provides simultaneous operation between mechanical cooling and economizer operation. Independent blade design ensures proper control and less than 1% leak rate. Includes hood and mesh bird screen filter integrated into the hood, dry bulb sensor, and barometric relief damper. Separate field accessories of single/dual enthalpy kits are also available.
- **Economizer for Horizontal Applications (S1-2EE04710224, S1-2EE04710324)** - Modulating integrated economizer provides simultaneous operation between the mechanical cooling and economizer operation. Independent blade design ensures proper control and less than 1% leak rate. Includes hood and mesh bird screen filter integrated into hood and dry bulb sensor. Separate field accessories of single enthalpy and dual enthalpy are available.
- **Barometric Relief Hood (S1-1RD0501)** - Used in conjunction with a horizontal economizer, the Barometric Relief Hood helps to equalize the building pressure caused by the fresh air introduced through the economizer fresh air hood.
- **Single/Dual Enthalpy Sensor (S1-HE-69630NS-2D)** - Sensor replaces supply air temperature dry bulb sensor standard in economizer kit. Provides improved economizer operation by sensing the dry bulb temperature of indoor supply air plus the enthalpy content of the outdoor air.
- **Duct/Unit Mount CO2 Kit (S1-2AQ04700924)** - Sensor kit detects CO2 levels automatically and overrides the economizer when CO2 levels rise above the preset limits.
- **Wall Mount CO2 Kit (S1-2AQ04701024)** - Sensor kit detects CO2 levels automatically and overrides the economizer when CO2 levels rise above the preset limits.
- **Supply Air Temperature Sensor Kit (S1-TE-63616E-2D)** - Outdoor supply air temperature sensor kit used with economizers.
- **Filter/Frame Kit (S1-1FF0602, S1-1FF0601)** - Kit contains the necessary hardware to field install return air filters into the base unit. The filter rack is suitable for either 1-in. filters or 2-in. filters.
- **Filter (S1-02647812000)** - Washable 1-in. filter. Two filters are required for A base units. Three filters are required for B base units.
- **Motorized Fresh Air Damper (S1-2MD04705224, S1-2MD04705124)** - Designed for duct mounted side supply/return and unit mounted down supply/return applications. Damper capable of providing 0% to 50% of outdoor air (field supplied). Closes on power loss, includes hood and screen assembly.

- **Rectangle to Round (Horizontal) Adapter (S1-1AK0110, S1-1AK0111)** - Kit includes one supply and one return air rectangle to round duct adapter. Adapters are preformed and designed to fit over current horizontal duct openings on the base unit. Transition is from rectangle to 12 in. round for the 1AK0110 kit and from rectangle to 14 in. round for the 1AK0111 kit.
- **Rectangle to Round (Downflow) Adapter (S1-1AK0108, S1-1AK0109)** - Kit includes one supply and one return air rectangle to round duct adapter. Adapters are preformed and designed to fit into current downflow duct openings on the roof curb. Transition is from rectangle to 16 in. round for the 1AK0108 kit and from rectangle to 18 in. round for the 1AK0109 kit.
- **Roof Curbs (S1-1RC0503, S1-1RC0501)** - NRCA approved curbs provide proper fit to base unit for rooftop installations. Curbs are designed to be assembled through hinge pins in each corner. Kit also provides seal strip to ensure an airtight seal. These are 8-in. high roof curbs.
- **Roof Curbs (S1-1RC0504, S1-1RC0502)** - NRCA approved curbs provide proper fit to base unit for rooftop installations. Curbs are designed for assembly through hinge pins in each corner. Kit also provides seal strip to ensure an airtight seal. These are 14-in. high roof curbs.
- **Transition Curb Kits (S1-1TC01*)** - These adapter kits allow use of existing field installed roof curbs, matching the PCE6 footprint to Affinity roof curbs or Carrier, Trane, or Goodman roof curbs. Curb adapters are optional for current generation Carrier replacements, but are recommended for previous generation applications. Refer to the PCE6 price pages for more details.
- **Manual Outdoor Damper (S1-1FA0502, S1-1FA0501)** - Provides 0% to 50% outdoor air capability (field adjustable). Designed for duct mounted side supply/return applications and unit mounted down supply/return applications. Includes hood and screen assembly.
- **Transformer Kit (S1-2EC06700124)** - This kit provides the necessary hardware to change single-phase models from the factory with 40-VA transformer capability to 75-VA transformer capability. Required on installations with an economizer or motorized damper.
- **Low Ambient Temperature Kit (S1-2LA04701024)** - Kit provides necessary hardware to convert unit to operate in cooling cycle down to 0°F. Standard unit operation is 55°F.
- **Base Rail Hole Cover Kit (S1-1HC0101)** - Kit provides necessary hardware to close off openings in base rails to block off openings and prevent animal entrance.
- **Single-Point Wiring Kits for 6HK Electric Heat Applications (S1-SPWK*)** - Kits provide field option for connecting electrical power supplies to the field installed 6HK kits to allow single-point connections for single-phase electric heat applications, with the exception of 25 kW kits.
- **Thermostat (S1-THXU280*)** - Compatible thermostat controls are available through accessory sourcing. For optimum performance, these outdoor units are fully compatible with the residential Hx™ Touch Screen Thermostat available through Source 1. For more information, refer to the *Thermostats & Controllers* section of the *Offering Catalog*.
- **Wall Thermostat** - The units are designed to operate with standard, 24-V electronic non power stealing and electro-mechanical thermostats. All units require the use of a multi-stage conventional thermostat.

* For additional kit numbers refer to the price pages.

GUIDE SPECIFICATIONS

GENERAL

Units shall be manufactured by Ducted Systems in an ISO 9001 certified facility. These packaged cooling and heating air conditioners are designed for outdoor installation. Only utility and duct connections are required at the point of installation. Air Conditioning units provide electric cooling and electric heating, with field installed electric heat kits from 2 kW to 25 kW for heating operation.

DESCRIPTION

Units shall be factory-assembled, single packaged, Air Conditioners with Electric Cooling/Electric Heating units, designed for outdoor installation. They shall have built-in, equal size, field convertible duct connections for supply/return or horizontal supply/return. The units shall be factory wired, piped, charged with R-410A refrigerant, and factory tested prior to shipment. All models shall be rated in accordance with DOE and AHRI test procedures for both heating and cooling operation. Units shall be CSA listed to the UL 1995/CAN/CSA No. 236-M90 standards.

- **Operating Efficiency** - All models shall be rated at a minimum of 16.0 SEER for cooling and heating operation rated in accordance with DOE requirements.
- **Low Operating Sound Level** - The upward airflow carries the normal operating noise up and away from the living area. The rigid top panel effectively isolates noise. Isolator mounted compressor and the rippled fins of the outdoor coil muffle the normal fan motor and compressor operating sounds. The unique formed base pan also aids in sound attenuation with its structural design. Sound ratings as tested under AHRI test procedures shall be less than 77 dB(A) for all models.

UNIT CABINET

Unit cabinet shall be a single piece design, with drip edges and no-seam corners to provide optimum water integrity. Unit shall have a rigidly mounted outdoor coil guard to provide protection from objects and personnel after installation. Indoor blower section shall be insulated with foil-faced or foam insulation, fastened to prevent insulation from entering the air stream. Cabinet panels shall be separate and easily removable for servicing and maintenance. Unit shall be built on a formed, design base pan, with embossments at critical points to add strength and rigidity and to aid in minimizing sound. Full perimeter base rails shall be provided to ensure reliable transit of equipment and facilitate overhead rigging, allowing truck access and proper sealing on roof curb applications. Base rails shall be easily removable, when required to lower unit height. Filters shall be field installed, furnished, and accessible through a removable access door, sealed airtight. The unit's vertical discharge and return duct configuration shall be designed to fit between standard 24-in. O.C. beams without modification to building structure, duct work and base unit.

- **Durable Finish** - The cabinet shall be made of G90 galvanized steel with a powder paint coating for appearance and protection. The pre-treated galvanized steel shall provide a better paint-to-steel bond, which resists corrosion and rust creep. Powder paint finish shall provide superior corrosion resistance (1,000 hour salt spray tested).

- **On-Site Flexibility** - All model sizes shall use a compact design cabinet in one of two footprints. This provides installer flexibility for placing the proper capacity unit on curbs or pads with the smallest footprint after the internal load has been determined. Field convertible duct connections from side shot to down shot allow the installer to have greater flexibility with less inventory.
- **Attractive Appearance** - A single-piece top cover containing a top-discharge outdoor fan arrangement shall be used, which requires less square footage on installation and provides a wider variety of installations. The one-piece design adds greater water integrity. Rounded corners with water drip edges add to the attractive appearance and prevent water penetration.
- **Convertible Airflow Design** - The bottom duct openings are covered when they leave the factory, ready to be used for a side supply/side return application. If a bottom supply/bottom return application is required, remove the two panels from the bottom of the unit and place them in the side supply/side return duct openings. No panel cutting is required and no accessory panel is necessary. Convertible airflow design allows maximum field flexibility and minimum inventory.
- **Utility Connections Made Easy** - Electric utility access shall be provided through the bottom or the side of the unit. Utility connections should be made quickly and with a minimum amount of field labor. A field supplied and field installed electrical disconnect switch must be installed.
- **Easy Service Access** - Individual access panels provide access to all major components, for example, compressors, indoor coils, blowers, controls/electric heat kits, and filters, making servicing easy. Removing these panels allows easy removal of components such as the blower assembly for maintenance and troubleshooting.
- **Top Discharge** - The top-discharge outdoor fan does not disrupt neighboring areas or dry out vegetation surrounding the unit. The warm air from the top mounted fan is blown up and away from the structure and any landscaping.
- **Outdoor Coil Grille** - All models utilize a stamped slotted design that provides superior impact protection against small objects during transit and after installation.

Indoor Blower Assembly - Blower shall be direct drive design. Blower wheel shall be double-inlet type with forward-curved blades, dynamically balanced to operate smoothly throughout the entire range of operation. Airflow design shall be constant air volume. Bearings shall be sealed and permanently lubricated for longer life and no maintenance. Blower assembly shall be a slide-out design for easy removal and cleaning. Indoor blower motors shall be equipped with a standard high efficiency brushless DC motor (constant torque), also known as an enhanced ECM motor.

Outdoor Fan Assembly - The outdoor fan shall be of the direct-driven propeller type, discharge air vertically, have aluminum blades riveted to a corrosion resistant steel spider bracket, and be statically balanced for smooth operation. The outdoor fan motor shall be totally enclosed with permanently lubricated ball bearings and internally protected against overload conditions.

REFRIGERANT COMPONENTS

- **Protected Compressor** - The compressor shall be a fully hermetic type, direct drive compressor, that is internally protected against high pressure and temperature. This is accomplished by the simultaneous operation of scroll bypass and a temperature thermal overload sensor, which protects the compressor if undesirable operating conditions occur. The hermetic motor shall be suction gas cooled and have a voltage range of +/- 10% of the unit nameplate voltage. Compressors shall have internal isolation and sound muffling to minimize vibration and noise, and be externally isolated on a dedicated, independent mounting.
- **Indoor Coils** - Indoor coils shall be of the direct expansion, draw through design and have aluminum plate fins mechanically bonded to seamless internally enhanced aluminum tubes with all joints brazed.
- **Condensate Pan** - A corrosion-resistant, long-lasting, water-tight pan is positioned below the indoor coil to collect and drain all condensate, preventing build-up of stagnant condensate. The condensate pan conforms to ASHRAE 62-89 standards (Ventilation for Acceptable Indoor Air Quality).
- **Condensate Drain** - The 3/4-in. NPT female connection is rigidly mounted to ensure proper fit and leak tight seal.
- **Outdoor Coils** - Outdoor coils shall have aluminum plate fins mechanically bonded to seamless internally enhanced copper tubes with all joints brazed, and be a draw through design.

Refrigerant Circuit and Refrigerant Safety Components shall include the following: thermal expansion valve (TXV) that shall be factory mounted and provided, filter/strainer to eliminate any foreign matter, and reversing valves to control refrigerant flow.

CONTROLS

- **Simple Control Circuit** - Field thermostat wiring connects to color-coded leads using twist on wire connections. Cooling controls use contactor and relays for simple application and troubleshooting. MATE-N-LOK plug connectors are used. Enhanced ECM indoor blower control is managed by a multi-stage indoor blower control board that includes field adjustable speed tap jumpers for maximum flexibility and product application. The electrical control box is not located in the compressor compartment. The controls are mounted to allow the separate access panel to be removed for troubleshooting and maintenance without affecting the normal system operating pressures. All wiring internal to the unit is color/number coded.
- **Pressure Switches** - A high pressure switch is standard in all units. It is an automatic reset switch. When discharge pressure reaches 650 psi, the compressor de-energizes until pressure reaches 450 psi.
- **Factory Testing** - Installation time and costs are reduced by easy power and control wiring connections. All units are completely wired, charged with R-410A, and tested prior to shipment. Test stations using a state-of-the-art computerized process system shall be used to ensure product quality. Refrigerant charge and component part numbers are verified using computer bar code scans during assembly. Vital run test statistics such as system pressure, motor currents, air velocity and temperature, unit vibration, and gas system safeties are monitored and recorded by the system to ensure unit performance. This data could be provided by serial number tracking if requested.
- **Electric Heat** - All electric heat models use 6HK electric heat kits, which are available in 208/230-1-60 from 2 kW to 25 kW. All kits are stageable above 10 kW. Single-point accessory kits are available for single-phase models. Single-phase single-point field wiring kits are available for all applications except 25 kW. Electric heat kits must be certified to UL 1995 standard requirements.

PHYSICAL DATA

NOMINAL TONNAGE	MODELS			
	PCE6A24	PCE6A36	PCE6B48	PCE6B60
	2.0	3.0	4.0	5.0
AHRI Cooling Performance				
Gross Capacity at AHRI A point (MBH)	24.3	36.9	47.1	60.8
AHRI net capacity (MBH)	24.0	36.0	46.0	59.0
EER	12.5	12.5	12.0	12.0
SEER	16.0	16.0	16.0	16.0
Nominal CFM	750	1275	1550	1825
System power (kW)	1.9	2.9	3.8	4.9
Refrigerant type	R-410A	R-410A	R-410A	R-410A
Refrigerant charge (lb-oz)	4-3	7-2	7-14	10-2
Dimensions (in.)				
Length	51 1/4	51 1/4	51 1/4	51 1/4
Width	35 3/4	35 3/4	45 3/4	45 3/4
Height	44	47	47	50
Operating Weight (lb)	343	461	483	500
Compressors				
Type	Scroll	Scroll	Scroll	Scroll
Stages	2	2	2	2
Outdoor Coil Data				
Face area (ft ²)	12.3	15.3	17.5	21.1
Rows	1	2	2	2
Fins per inch	22	22	22	22
Tube diameter (mm)	7	7	7	7
Circuitry Type	Straight	Interlaced	Interlaced	Interlaced
Indoor Coil Data				
Face area (ft ²)	4.6	4.6	6.2	6.2
Rows	2	3	3	4
Fins per inch	16	16	16	16
Tube diameter (in.)	3/8	3/8	3/8	3/8
Circuitry Type	Interlaced	Interlaced	Interlaced	Interlaced
Refrigerant control	TXV	TXV	TXV	TXV
Outdoor Fan Data				
Fan diameter (in.)	24	24	26	26
Type	Prop	Prop	Prop	Prop
Drive type	Direct	Direct	Direct	Direct
Number of speeds	1	1	1	1
Motor HP each	1/8	1/3	1/3	1/3
RPM	790	850	850	850
Nominal total CFM	2400	2400	3200	3200
Direct Drive Indoor Blower Data				
Blower Size (in.)	11 x 8	11 x 10	11 x 10	11 x 10
Type	Centrifugal	Centrifugal	Centrifugal	Centrifugal
Motor HP each	1/2	1/2	3/4	1
RPM	1400 Maximum	1400 Maximum	1400 Maximum	1400 Maximum
Frame size	48	48	48	48
Filters				
Filter Size	A	A	B	B
Quantity - Size	Field-supplied external filters must be sized so as not to exceed 300 fpm air velocity through disposable filters. For internal filter use, a filter rack kit is available. Consult the instructions supplied with the kit for replacement filter sizes. A = 20 in. x 20 in., B = 20 in. x 30 in.			

COOLING PERFORMANCE DATA - 2 TON (LOW SPEED)																
PACKAGED UNIT MODEL NO.		PCE6A24														
CONDENSER ENTERING AIR TEMPERATURE (°F)	ID CFM	450					650					850				
		80	80	75	80	80	80	80	75	80	80	80	80	75	80	80
		IDWB	57	62	62	67	72	57	62	62	67	72	57	62	62	67
55 / 45	T.C.	19.7	25.8	23.8	28.2	28.6	22.2	28.7	26.6	32.1	31.1	24.8	31.7	29.5	36.1	33.6
	S.C.	18.4	18.9	14.7	16.2	12.5	20.9	23.1	17.9	19.5	14.7	23.4	27.3	21.1	22.7	16.9
	K.W.	0.91	1.15	1.15	1.15	1.16	0.96	1.21	1.21	1.22	1.23	1.00	1.27	1.27	1.28	1.29
65 / 55	T.C.	18.3	21.4	20.2	24.1	25.3	20.8	23.9	22.3	26.8	27.2	23.4	26.3	24.4	29.5	29.2
	S.C.	17.1	16.4	13.0	14.4	11.2	19.6	20.1	15.9	17.4	13.3	22.1	23.7	18.9	20.5	15.3
	K.W.	0.99	1.10	1.10	1.10	1.10	1.03	1.16	1.16	1.16	1.16	1.08	1.21	1.21	1.22	1.22
75 / 63	T.C.	16.8	17.0	16.6	20.0	22.0	19.4	19.0	18.0	21.4	23.4	22.1	20.9	19.3	22.9	24.8
	S.C.	15.7	13.9	11.3	12.6	10.0	18.2	17.0	13.9	15.4	11.8	20.7	20.1	16.6	18.3	13.7
	K.W.	1.06	1.06	1.06	1.05	1.04	1.11	1.10	1.11	1.10	1.10	1.16	1.15	1.16	1.16	1.16
85 / 69	T.C.	15.8	15.5	15.2	18.5	20.0	17.7	17.3	18.4	19.8	21.2	19.7	19.2	21.6	21.0	22.5
	S.C.	15.0	13.2	10.7	11.9	8.9	16.9	15.9	13.3	14.6	10.7	18.7	18.6	15.9	17.4	12.4
	K.W.	1.17	1.16	1.17	1.16	1.15	1.21	1.21	1.22	1.21	1.20	1.26	1.26	1.27	1.27	1.26
95 / 75	T.C.	14.8	14.0	13.8	17.1	18.1	16.0	15.7	18.8	18.1	19.1	17.3	17.5	23.8	19.1	20.1
	S.C.	14.3	12.5	10.0	11.1	7.8	15.6	14.7	12.7	13.9	9.5	16.8	17.0	15.3	16.6	11.1
	K.W.	1.28	1.27	1.27	1.26	1.25	1.32	1.32	1.32	1.32	1.31	1.36	1.37	1.37	1.37	1.36
105 / 83	T.C.	13.0	12.3	13.2	14.7	16.1	13.9	13.5	15.8	15.3	16.6	14.8	14.8	18.4	15.9	17.2
	S.C.	12.6	11.2	9.3	10.1	7.1	13.5	12.8	11.0	12.1	8.6	14.4	14.4	12.7	14.1	10.2
	K.W.	1.42	1.41	1.42	1.41	1.40	1.47	1.46	1.47	1.47	1.46	1.51	1.51	1.52	1.52	1.51
115 / 89	T.C.	11.2	10.6	12.5	12.4	14.1	11.9	11.4	12.8	12.6	14.2	12.5	12.1	13.1	12.8	14.4
	S.C.	10.9	10.0	8.6	9.1	6.5	11.5	10.9	9.4	10.4	7.9	12.2	11.8	10.2	11.8	9.2
	K.W.	1.56	1.56	1.56	1.56	1.55	1.61	1.60	1.61	1.61	1.60	1.65	1.65	1.66	1.66	1.66
125 / 95	T.C.	9.5	9.0	11.8	10.1	12.1	9.8	9.2	9.9	9.8	11.8	10.2	9.5	7.9	9.6	11.5
	S.C.	9.2	8.7	7.9	8.1	5.8	9.6	9.0	7.8	8.7	7.1	9.9	9.2	7.7	9.4	8.3
	K.W.	1.70	1.70	1.71	1.70	1.69	1.75	1.74	1.75	1.76	1.75	1.79	1.79	1.79	1.81	1.80

COOLING PERFORMANCE DATA - 2 TON (HIGH SPEED)																
PACKAGED UNIT MODEL NO.		PCE6A24														
CONDENSER ENTERING AIR TEMPERATURE (°F)	ID CFM	550					750					950				
		80	80	75	80	80	80	80	75	80	80	80	80	75	80	80
		IDWB	57	62	62	67	72	57	62	62	67	72	57	62	62	67
55 / 45	T.C.	25.0	26.3	25.1	28.4	29.9	28.5	29.1	27.5	30.9	31.9	30.9	30.8	28.9	32.5	32.8
	S.C.	24.1	20.4	16.8	17.4	14.4	27.9	24.5	19.7	20.6	16.2	30.7	27.5	21.5	22.8	16.9
	K.W.	1.32	1.55	1.55	1.56	1.57	1.17	1.48	1.48	1.49	1.51	1.34	1.73	1.72	1.74	1.76
65 / 55	T.C.	23.2	24.5	23.6	27.1	28.8	26.6	27.1	25.8	29.9	31.5	29.1	28.7	27.1	31.7	33.2
	S.C.	22.4	19.5	16.1	17.1	14.1	26.2	23.6	19.2	20.4	16.3	28.9	26.6	21.3	22.8	17.4
	K.W.	1.46	1.58	1.58	1.59	1.61	1.31	1.47	1.47	1.49	1.50	1.48	1.68	1.68	1.70	1.71
75 / 63	T.C.	21.3	22.7	22.1	25.8	27.8	24.8	25.2	24.2	28.8	31.2	27.3	26.6	25.2	30.9	33.5
	S.C.	20.8	18.6	15.5	16.8	13.8	24.4	22.7	18.8	20.3	16.4	27.1	25.8	21.1	22.7	17.9
	K.W.	1.60	1.60	1.61	1.63	1.64	1.46	1.46	1.46	1.48	1.49	1.63	1.62	1.63	1.65	1.66
85 / 69	T.C.	20.4	21.8	20.9	24.4	26.0	22.8	24.0	22.9	26.8	28.6	24.1	25.2	23.8	28.3	30.2
	S.C.	20.1	18.3	14.9	16.0	12.6	22.5	22.0	18.2	19.4	15.1	24.0	24.7	20.5	21.9	16.5
	K.W.	1.79	1.79	1.79	1.81	1.82	1.64	1.64	1.64	1.66	1.67	1.82	1.81	1.81	1.83	1.84
95 / 75	T.C.	19.5	20.9	19.7	23.1	24.3	20.7	22.8	21.6	24.9	26.0	20.9	23.8	22.5	25.6	26.8
	S.C.	19.4	18.1	14.2	15.3	11.5	20.6	21.3	17.6	18.6	13.8	20.8	23.6	19.9	21.0	15.1
	K.W.	1.98	1.98	1.97	1.99	2.00	1.83	1.82	1.83	1.85	1.85	2.01	1.99	1.99	2.02	2.02
105 / 83	T.C.	17.9	18.4	17.8	20.8	22.2	19.2	20.2	19.1	22.1	23.5	19.5	21.0	19.4	22.4	23.8
	S.C.	17.8	16.5	13.5	14.3	10.8	19.0	19.2	16.0	17.3	12.9	19.3	20.9	17.6	19.3	14.1
	K.W.	2.24	2.24	2.24	2.26	2.27	2.09	2.09	2.09	2.11	2.12	2.27	2.25	2.26	2.28	2.29
115 / 89	T.C.	16.4	15.9	16.0	18.6	20.2	17.7	17.6	16.7	19.4	21.1	18.0	18.4	16.4	19.3	21.0
	S.C.	16.2	15.0	12.7	13.3	10.1	17.6	17.1	14.6	15.9	12.1	17.9	18.2	15.5	17.6	13.2
	K.W.	2.50	2.50	2.50	2.51	2.53	2.35	2.35	2.35	2.37	2.38	2.52	2.51	2.51	2.53	2.56
125 / 95	T.C.	14.8	13.5	14.2	16.3	18.2	16.2	15.1	14.3	16.7	18.6	16.6	15.7	13.4	16.1	18.1
	S.C.	14.7	13.4	12.0	12.3	9.4	16.1	15.0	13.1	14.6	11.3	16.5	15.6	13.3	16.0	12.2
	K.W.	2.75	2.75	2.76	2.77	2.79	2.60	2.60	2.61	2.62	2.65	2.77	2.77	2.77	2.79	2.82

COOLING PERFORMANCE DATA - 3 TON (LOW SPEED)																
PACKAGED UNIT MODEL NO.		PCE6A36														
CONDENSER ENTERING AIR TEMPERATURE (°F)	ID CFM	650					850					1050				
	IDDB	80	80	75	80	80	80	80	75	80	80	80	80	75	80	80
	IDWB	57	62	62	67	72	57	62	62	67	72	57	62	62	67	72
55 / 45	T.C.	27.1	29.0	27.3	32.0	34.1	30.9	31.8	30.0	36.4	37.0	33.6	33.7	31.8	39.9	38.9
	S.C.	26.7	23.9	19.0	20.8	16.3	30.4	28.3	22.5	24.5	18.8	33.2	31.7	25.0	27.2	20.2
	K.W.	1.42	1.40	1.41	1.39	1.38	1.34	1.33	1.33	1.32	1.31	1.54	1.53	1.53	1.52	1.51
65 / 55	T.C.	24.9	26.8	25.7	30.5	33.2	28.5	29.6	28.3	34.3	37.4	31.2	31.4	29.9	37.1	40.6
	S.C.	24.3	22.5	18.2	20.1	16.0	28.0	26.6	21.6	23.7	18.7	30.7	29.7	24.1	26.3	20.4
	K.W.	1.55	1.54	1.54	1.53	1.51	1.47	1.46	1.46	1.45	1.44	1.66	1.66	1.66	1.65	1.64
75 / 63	T.C.	22.6	24.6	24.2	28.9	32.2	26.2	27.3	26.6	32.2	37.8	28.7	29.0	28.1	34.4	42.4
	S.C.	22.0	21.1	17.3	19.4	15.6	25.6	24.9	20.8	22.9	18.5	28.2	27.7	23.2	25.5	20.5
	K.W.	1.69	1.67	1.68	1.66	1.63	1.60	1.59	1.60	1.58	1.56	1.79	1.79	1.80	1.78	1.77
85 / 69	T.C.	21.9	22.4	22.4	26.8	29.7	25.3	24.9	25.9	29.6	33.8	27.6	26.5	28.6	31.3	36.8
	S.C.	21.5	19.9	16.4	18.2	14.4	24.8	23.3	19.7	21.6	17.1	27.2	25.6	22.0	24.1	18.8
	K.W.	1.86	1.85	1.85	1.83	1.81	1.78	1.77	1.78	1.76	1.74	1.97	1.97	1.98	1.96	1.94
95 / 75	T.C.	21.3	20.3	20.5	24.7	27.3	24.4	22.6	25.3	27.0	29.7	26.5	23.9	29.0	28.3	31.2
	S.C.	21.0	18.7	15.4	17.0	13.1	24.0	21.6	18.6	20.4	15.6	26.1	23.6	20.8	22.7	17.2
	K.W.	2.04	2.02	2.03	2.01	1.98	1.95	1.95	1.95	1.93	1.91	2.14	2.15	2.15	2.14	2.11
105 / 83	T.C.	19.2	18.6	18.3	22.0	24.6	21.8	20.6	21.8	24.0	26.8	23.5	21.6	24.3	25.1	28.0
	S.C.	19.0	17.4	14.5	15.6	12.0	21.6	19.9	17.1	18.8	14.4	23.2	21.3	18.7	21.1	15.8
	K.W.	2.27	2.26	2.26	2.24	2.22	2.18	2.18	2.19	2.17	2.15	2.38	2.38	2.39	2.37	2.35
115 / 89	T.C.	17.2	16.9	16.1	19.4	22.0	19.4	18.7	18.4	21.1	23.9	20.6	19.4	19.7	21.9	24.8
	S.C.	17.1	16.2	13.6	14.3	11.0	19.2	18.1	15.7	17.4	13.3	20.3	19.1	16.8	19.4	14.6
	K.W.	2.49	2.49	2.49	2.48	2.45	2.41	2.41	2.41	2.40	2.38	2.61	2.60	2.61	2.60	2.59
125 / 95	T.C.	15.2	15.3	14.0	16.7	19.4	17.0	16.7	15.0	18.2	21.0	17.7	17.2	15.0	18.7	21.7
	S.C.	15.2	14.9	12.7	13.0	9.9	16.8	16.4	14.2	15.9	12.1	17.5	16.9	14.8	17.8	13.3
	K.W.	2.71	2.72	2.72	2.71	2.68	2.63	2.63	2.64	2.63	2.61	2.83	2.83	2.84	2.83	2.83

COOLING PERFORMANCE DATA - 3 TON (HIGH SPEED)																
PACKAGED UNIT MODEL NO.		PCE6A36														
CONDENSER ENTERING AIR TEMPERATURE (°F)	ID CFM	950					1150					1350				
	IDDB	80	80	75	80	80	80	80	75	80	80	80	80	75	80	80
	IDWB	57	62	62	67	72	57	62	62	67	72	57	62	62	67	72
55 / 45	T.C.	38.1	41.0	39.6	44.8	47.8	41.2	43.3	41.8	48.4	49.9	44.4	45.6	44.0	52.0	52.1
	S.C.	32.5	29.4	24.2	25.2	19.8	35.6	32.6	26.8	28.0	21.5	38.7	35.9	29.4	30.8	23.1
	K.W.	1.96	1.97	1.98	1.99	2.02	2.04	2.05	2.05	2.07	2.10	2.13	2.13	2.12	2.15	2.17
65 / 55	T.C.	35.7	38.2	37.4	43.0	46.7	38.7	40.3	39.5	45.8	49.8	41.6	42.5	41.5	48.6	52.9
	S.C.	30.4	27.9	23.2	24.5	19.5	33.2	30.9	25.7	27.2	21.3	36.0	34.0	28.2	29.8	23.2
	K.W.	2.11	2.12	2.12	2.14	2.17	2.19	2.20	2.20	2.22	2.25	2.28	2.27	2.27	2.30	2.32
75 / 63	T.C.	33.2	35.4	35.2	41.2	45.7	36.1	37.4	37.1	43.2	49.7	38.9	39.4	39.0	45.2	53.7
	S.C.	28.2	26.4	22.1	23.9	19.2	30.7	29.2	24.6	26.4	21.2	33.2	32.1	27.0	28.8	23.2
	K.W.	2.26	2.27	2.27	2.30	2.32	2.34	2.35	2.34	2.37	2.40	2.42	2.42	2.41	2.44	2.47
85 / 69	T.C.	32.1	33.1	32.9	38.6	42.7	34.7	34.9	34.5	40.4	45.7	37.3	36.7	36.2	42.3	48.7
	S.C.	27.4	25.2	21.0	22.7	18.0	29.8	27.9	23.3	27.0	19.8	32.2	30.6	25.7	31.2	21.7
	K.W.	2.45	2.46	2.46	2.48	2.50	2.53	2.53	2.53	2.55	2.58	2.61	2.61	2.60	2.63	2.65
95 / 75	T.C.	30.9	30.8	30.5	36.0	39.7	33.3	32.4	31.9	37.7	41.7	35.7	33.9	33.4	39.4	43.7
	S.C.	26.6	24.1	19.8	21.4	16.7	28.8	26.7	22.1	27.5	18.4	31.1	29.2	24.3	33.7	20.1
	K.W.	2.64	2.65	2.65	2.66	2.68	2.72	2.72	2.72	2.74	2.75	2.80	2.79	2.79	2.81	2.83
105 / 83	T.C.	28.5	27.9	27.5	32.7	36.4	30.3	29.5	28.6	34.1	38.1	32.2	31.0	29.8	35.5	39.8
	S.C.	24.6	22.4	18.5	20.0	15.5	26.3	24.6	20.6	24.7	17.2	28.0	26.7	22.7	29.4	18.8
	K.W.	2.91	2.91	2.91	2.92	2.94	2.99	2.99	2.98	3.00	3.02	3.07	3.06	3.05	3.07	3.10
115 / 89	T.C.	26.1	25.1	24.5	29.5	33.2	27.4	26.7	25.4	30.7	34.6	28.8	28.2	26.3	31.8	36.1
	S.C.	22.6	20.7	17.2	18.7	14.4	23.9	22.5	19.1	22.0	16.0	25.1	24.4	21.0	25.3	17.5
	K.W.	3.17	3.17	3.16	3.18	3.20	3.25	3.25	3.23	3.25	3.28	3.33	3.32	3.31	3.33	3.35
125 / 95	T.C.	23.8	22.4	21.6	26.3	30.0	24.6	23.9	22.2	27.2	31.1	25.4	25.4	22.8	28.0	32.3
	S.C.	20.7	19.0	16.0	17.3	13.3	21.4	20.5	17.7	19.3	14.8	22.1	22.0	19.4	21.2	16.3
	K.W.	3.43	3.43	3.41	3.43	3.46	3.51	3.51	3.49	3.51	3.54	3.59	3.58	3.57	3.58	3.61

COOLING PERFORMANCE DATA - 4 TON (LOW SPEED)																		
PACKAGED UNIT MODEL NO.		PCE6B48																
CONDENSER ENTERING AIR TEMPERATURE (°F)	ID CFM	950					1150					1350						
		IDDB	80	80	75	80	80	80	80	75	80	80	80	80	80	75	80	80
		IDWB	57	62	62	67	72	57	62	62	67	72	57	62	62	67	72	
55 / 45	T.C.	37.1	40.7	40.1	44.8	49.2	39.7	42.7	41.7	48.6	50.9	42.3	44.7	43.3	52.5	52.7		
	S.C.	37.0	34.3	28.9	29.6	24.1	39.3	38.0	31.5	32.7	25.8	41.6	41.7	34.0	35.7	27.5		
	K.W.	1.77	1.76	1.77	1.76	1.75	1.83	1.82	1.83	1.82	1.81	1.88	1.88	1.88	1.88	1.87		
65 / 55	T.C.	34.5	37.5	37.0	42.3	46.7	37.2	39.4	38.6	45.0	49.8	39.9	41.4	40.3	47.8	52.9		
	S.C.	34.3	32.3	27.0	28.3	22.9	36.8	35.9	29.7	31.3	24.9	39.3	39.4	32.4	34.2	26.9		
	K.W.	1.94	1.93	1.94	1.92	1.91	2.00	1.99	1.99	1.98	1.97	2.05	2.05	2.05	2.04	2.03		
75 / 63	T.C.	32.0	34.2	33.8	39.7	44.3	34.8	36.1	35.5	41.4	48.8	37.6	38.0	37.2	43.1	53.2		
	S.C.	31.5	30.3	25.0	27.1	21.6	34.2	33.7	27.9	29.9	23.9	37.0	37.1	30.7	32.7	26.2		
	K.W.	2.11	2.10	2.10	2.09	2.07	2.16	2.16	2.16	2.14	2.13	2.22	2.22	2.22	2.20	2.19		
85 / 69	T.C.	30.0	31.1	30.8	36.5	40.7	32.6	32.8	32.3	38.0	43.8	35.1	34.5	33.8	39.6	46.8		
	S.C.	29.5	28.6	23.3	25.3	20.0	32.0	31.2	26.1	28.0	22.1	34.5	33.8	28.8	30.8	24.2		
	K.W.	2.32	2.31	2.32	2.30	2.28	2.38	2.37	2.37	2.36	2.34	2.43	2.43	2.43	2.42	2.40		
95 / 75	T.C.	28.1	28.0	27.8	33.2	37.2	30.3	29.5	29.1	34.6	38.8	32.6	31.0	30.3	36.0	40.4		
	S.C.	27.6	27.0	21.6	23.5	18.4	29.8	28.7	24.3	26.2	20.3	32.1	30.5	27.0	28.9	22.3		
	K.W.	2.54	2.52	2.53	2.51	2.49	2.59	2.58	2.59	2.57	2.55	2.65	2.64	2.65	2.63	2.61		
105 / 83	T.C.	24.8	24.6	24.1	28.9	32.7	26.8	25.9	25.1	30.0	33.9	28.8	27.3	26.1	31.0	35.2		
	S.C.	24.4	23.8	19.9	21.5	16.6	26.4	25.3	21.8	23.8	18.4	28.3	26.9	23.8	26.2	20.2		
	K.W.	2.80	2.79	2.79	2.78	2.77	2.86	2.85	2.85	2.84	2.83	2.91	2.91	2.91	2.90	2.89		
115 / 89	T.C.	21.7	21.2	20.4	24.6	28.3	23.4	22.5	21.2	25.4	29.2	25.0	23.8	22.1	26.2	30.2		
	S.C.	21.4	20.7	18.2	19.5	14.8	23.0	22.1	19.5	21.6	16.5	24.6	23.4	20.8	23.6	18.2		
	K.W.	3.05	3.05	3.05	3.04	3.03	3.11	3.11	3.11	3.10	3.09	3.17	3.17	3.17	3.16	3.15		
125 / 95	T.C.	18.6	17.9	16.7	20.4	23.9	19.9	19.1	17.4	20.9	24.5	21.3	20.3	18.0	21.4	25.2		
	S.C.	18.3	17.6	16.5	17.5	13.0	19.6	18.8	17.1	19.3	14.6	20.9	20.0	17.7	21.0	16.3		
	K.W.	3.30	3.31	3.31	3.30	3.30	3.37	3.37	3.37	3.36	3.36	3.43	3.43	3.42	3.42	3.42		

COOLING PERFORMANCE DATA - 4 TON (HIGH SPEED)																		
PACKAGED UNIT MODEL NO.		PCE6B48																
CONDENSER ENTERING AIR TEMPERATURE (°F)	ID CFM	1350					1550					1750						
		IDDB	80	80	75	80	80	80	80	75	80	80	80	80	80	75	80	80
		IDWB	57	62	62	67	72	57	62	62	67	72	57	62	62	67	72	
55 / 45	T.C.	49.9	54.4	52.9	59.8	64.3	52.3	56.3	54.9	61.9	66.3	54.6	58.1	56.8	64.0	68.4		
	S.C.	49.4	45.5	38.0	39.6	31.5	51.8	48.6	40.4	42.2	33.2	54.1	51.8	42.9	44.7	35.0		
	K.W.	2.59	2.62	2.62	2.66	2.71	2.68	2.71	2.70	2.74	2.79	2.78	2.79	2.79	2.82	2.87		
65 / 55	T.C.	47.4	50.8	50.0	56.7	61.8	49.5	52.5	51.7	58.5	64.2	51.6	54.1	53.4	60.3	66.7		
	S.C.	46.8	43.2	36.4	38.1	30.6	48.9	46.3	38.9	40.5	32.4	51.0	49.3	41.3	42.9	34.3		
	K.W.	2.81	2.83	2.83	2.88	2.93	2.90	2.91	2.91	2.96	3.01	2.99	2.99	2.99	3.04	3.09		
75 / 63	T.C.	44.8	47.2	47.0	53.6	59.2	46.7	48.7	48.5	55.1	62.1	48.6	50.1	50.1	56.6	64.9		
	S.C.	44.3	41.0	34.8	36.5	29.7	46.1	43.9	37.3	38.8	31.6	48.0	46.8	39.7	41.2	33.6		
	K.W.	3.03	3.03	3.03	3.09	3.14	3.12	3.11	3.12	3.18	3.22	3.21	3.20	3.20	3.26	3.31		
85 / 69	T.C.	42.5	44.2	44.0	50.1	55.3	44.3	45.5	45.2	51.5	57.4	46.2	46.8	46.5	52.9	59.4		
	S.C.	41.9	39.4	33.2	34.7	27.8	43.7	42.3	35.5	37.0	29.6	45.6	45.1	37.8	39.4	31.3		
	K.W.	3.30	3.30	3.31	3.36	3.40	3.39	3.39	3.39	3.44	3.49	3.48	3.47	3.47	3.52	3.57		
95 / 75	T.C.	40.1	41.1	40.9	46.6	51.4	41.9	42.3	41.9	47.8	52.6	43.8	43.4	42.9	49.1	53.9		
	S.C.	39.6	37.9	31.7	32.9	25.9	41.4	40.7	33.8	35.2	27.5	43.2	43.4	35.9	37.6	29.1		
	K.W.	3.57	3.58	3.58	3.62	3.67	3.66	3.66	3.66	3.70	3.75	3.75	3.74	3.74	3.79	3.83		
105 / 83	T.C.	36.9	37.2	36.7	42.2	46.8	38.3	38.3	37.5	43.2	47.8	39.7	39.4	38.2	44.1	48.9		
	S.C.	36.4	35.0	29.7	30.9	24.0	37.8	37.1	31.6	33.1	25.5	39.2	39.2	33.5	35.3	27.1		
	K.W.	3.97	3.97	3.96	4.01	4.05	4.06	4.05	4.04	4.09	4.13	4.15	4.13	4.12	4.17	4.21		
115 / 89	T.C.	33.8	33.4	32.7	37.9	42.3	34.8	34.4	33.2	38.6	43.1	35.8	35.4	33.7	39.3	43.9		
	S.C.	33.3	32.1	27.7	28.9	22.0	34.3	33.6	29.4	31.0	23.6	35.3	35.1	31.1	33.2	25.1		
	K.W.	4.35	4.34	4.33	4.38	4.42	4.44	4.43	4.41	4.46	4.50	4.53	4.51	4.49	4.54	4.58		
125 / 95	T.C.	30.7	29.6	28.6	33.6	37.9	31.2	30.5	28.9	34.1	38.4	31.8	31.5	29.1	34.5	39.0		
	S.C.	30.3	29.2	25.8	26.9	20.1	30.8	30.1	27.3	28.9	21.6	31.4	31.1	28.7	31.0	23.1		
	K.W.	4.74	4.72	4.70	4.75	4.79	4.83	4.81	4.78	4.83	4.87	4.91	4.89	4.86	4.91	4.95		

COOLING PERFORMANCE DATA - 5 TON (LOW SPEED)																
PACKAGED UNIT MODEL NO.		PCE6B60														
CONDENSER ENTERING AIR TEMPERATURE (°F)	ID CFM	1150					1350					1550				
	IDDB	80	80	75	80	80	80	80	75	80	80	80	80	75	80	80
	IDWB	57	62	62	67	72	57	62	62	67	72	57	62	62	67	72
55 / 45	T.C.	48.1	53.1	52.5	58.7	63.7	52.6	55.0	54.8	63.3	65.8	57.0	56.9	57.2	67.9	67.9
	S.C.	48.0	44.8	37.8	38.6	31.2	51.1	48.6	41.3	42.2	33.2	54.3	52.4	44.7	45.8	35.2
	K.W.	2.23	2.22	2.23	2.23	2.23	2.29	2.29	2.30	2.29	2.29	2.36	2.36	2.36	2.35	2.35
65 / 55	T.C.	45.6	48.8	48.3	54.6	60.0	49.5	50.7	50.3	58.4	63.0	53.3	52.5	52.2	62.1	66.0
	S.C.	45.2	42.4	35.5	36.6	29.4	48.4	46.2	38.6	40.0	31.6	51.6	50.0	41.8	43.4	33.8
	K.W.	2.45	2.44	2.45	2.44	2.44	2.51	2.51	2.51	2.50	2.50	2.57	2.57	2.57	2.56	2.56
75 / 63	T.C.	43.1	44.5	44.2	50.5	56.4	46.4	46.4	45.7	53.4	60.3	49.6	48.2	47.2	56.3	64.2
	S.C.	42.4	40.0	33.2	34.5	27.6	45.6	43.8	36.0	37.8	29.9	48.9	47.6	38.9	41.1	32.3
	K.W.	2.67	2.66	2.66	2.65	2.64	2.73	2.72	2.73	2.72	2.71	2.79	2.79	2.79	2.78	2.77
85 / 69	T.C.	40.3	41.4	40.5	47.0	52.0	43.1	43.3	41.9	49.2	54.8	46.0	45.2	43.2	51.4	57.6
	S.C.	39.1	37.8	31.1	32.6	25.6	42.3	40.8	34.1	35.8	27.7	45.4	43.8	37.1	39.0	29.9
	K.W.	2.95	2.94	2.94	2.94	2.92	3.01	3.00	3.01	3.00	2.99	3.07	3.07	3.07	3.06	3.05
95 / 75	T.C.	37.6	38.4	36.8	43.5	47.7	39.9	40.3	38.0	45.0	49.4	42.3	42.1	39.2	46.6	51.1
	S.C.	35.9	35.5	29.1	30.7	23.5	38.9	37.8	32.2	33.7	25.5	41.9	40.0	35.3	36.8	27.6
	K.W.	3.22	3.22	3.22	3.22	3.21	3.29	3.29	3.28	3.28	3.27	3.35	3.35	3.35	3.35	3.33
105 / 83	T.C.	33.2	33.1	31.3	37.3	41.7	35.0	34.7	32.3	38.4	42.9	36.9	36.3	33.2	39.4	44.1
	S.C.	32.0	31.2	26.1	28.0	21.2	34.3	32.8	28.2	30.3	23.0	36.6	34.5	30.3	32.5	24.9
	K.W.	3.58	3.57	3.57	3.57	3.57	3.64	3.64	3.64	3.64	3.63	3.71	3.71	3.70	3.71	3.70
115 / 89	T.C.	29.0	28.0	26.0	31.3	35.9	30.3	29.3	26.7	31.9	36.6	31.6	30.6	27.5	32.5	37.3
	S.C.	28.3	26.9	23.3	25.3	18.9	29.8	28.0	24.4	26.9	20.6	31.4	29.1	25.5	28.4	22.4
	K.W.	3.93	3.92	3.91	3.92	3.92	3.99	3.98	3.98	3.99	3.99	4.05	4.05	4.04	4.05	4.05
125 / 95	T.C.	24.8	22.8	20.7	25.3	30.1	25.6	23.9	21.2	25.5	30.3	26.4	24.9	21.7	25.6	30.6
	S.C.	24.6	22.6	20.5	22.7	16.6	25.4	23.1	20.5	23.5	18.2	26.1	23.7	20.6	24.3	19.8
	K.W.	4.27	4.26	4.26	4.27	4.28	4.34	4.32	4.32	4.33	4.34	4.40	4.39	4.38	4.40	4.41

COOLING PERFORMANCE DATA - 5 TON (HIGH SPEED)																
PACKAGED UNIT MODEL NO.		PCE6B60														
CONDENSER ENTERING AIR TEMPERATURE (°F)	ID CFM	1600					1800					2000				
	IDDB	80	80	75	80	80	80	80	75	80	80	80	80	75	80	80
	IDWB	57	62	62	67	72	57	62	62	67	72	57	62	62	67	72
55 / 45	T.C.	63.4	66.7	66.4	71.5	81.4	66.2	68.5	68.6	73.6	91.5	69.0	70.4	70.8	75.7	101.6
	S.C.	62.1	55.9	48.8	47.7	40.2	64.6	59.3	52.0	50.0	42.5	67.1	62.7	55.2	52.3	44.8
	K.W.	3.33	3.38	3.36	3.45	3.26	3.44	3.47	3.46	3.54	3.34	3.55	3.56	3.55	3.64	3.43
65 / 55	T.C.	59.7	63.0	62.7	69.2	79.7	62.4	64.9	64.7	72.2	89.8	65.1	66.9	66.8	75.2	99.8
	S.C.	58.8	54.7	46.9	47.0	39.7	61.3	58.0	50.0	49.7	42.0	63.9	61.4	53.1	52.4	44.3
	K.W.	3.60	3.64	3.64	3.72	3.67	3.71	3.74	3.73	3.81	3.75	3.82	3.83	3.82	3.90	3.84
75 / 63	T.C.	56.0	59.3	59.0	66.9	78.0	58.6	61.3	60.9	70.8	88.0	61.3	63.4	62.8	74.7	98.1
	S.C.	55.4	53.4	45.0	46.4	39.2	58.1	56.7	48.0	49.5	41.5	60.8	60.0	51.0	52.6	43.8
	K.W.	3.88	3.90	3.91	3.99	4.07	3.99	4.00	4.00	4.08	4.16	4.10	4.11	4.10	4.17	4.25
85 / 69	T.C.	53.6	56.0	55.5	63.1	71.8	55.9	57.9	57.0	65.9	77.8	58.1	59.9	58.4	68.6	83.8
	S.C.	53.1	50.9	42.9	44.2	36.3	55.3	53.9	45.6	47.1	38.5	57.5	57.0	48.3	50.1	40.6
	K.W.	4.26	4.26	4.27	4.34	4.43	4.36	4.36	4.36	4.44	4.52	4.47	4.47	4.45	4.53	4.62
95 / 75	T.C.	51.2	52.8	52.1	59.4	65.5	53.1	54.5	53.1	60.9	67.5	54.9	56.3	54.1	62.5	69.5
	S.C.	50.9	48.3	40.9	42.0	33.5	52.5	51.1	43.3	44.8	35.4	54.2	54.0	45.7	47.6	37.4
	K.W.	4.63	4.62	4.63	4.70	4.78	4.73	4.72	4.72	4.79	4.88	4.83	4.83	4.81	4.89	4.98
105 / 83	T.C.	49.5	48.2	47.4	53.9	59.7	51.2	49.8	46.9	55.1	61.3	52.9	51.4	46.4	56.4	62.9
	S.C.	49.2	45.1	38.3	39.7	31.1	50.8	47.4	39.6	42.3	33.0	52.4	49.8	40.8	44.9	34.8
	K.W.	4.91	5.16	5.16	5.23	5.31	5.01	5.26	5.25	5.32	5.41	5.10	5.36	5.34	5.42	5.50
115 / 89	T.C.	47.8	43.9	42.8	48.6	54.1	49.4	45.2	40.9	49.5	55.3	50.9	46.5	39.0	50.4	56.5
	S.C.	47.6	41.9	35.9	37.4	28.8	49.1	43.8	36.0	39.8	30.6	50.6	45.8	36.0	42.3	32.4
	K.W.	5.18	5.69	5.68	5.75	5.83	5.27	5.79	5.78	5.84	5.92	5.36	5.89	5.87	5.93	6.01
125 / 95	T.C.	46.1	39.5	38.3	43.3	48.5	47.5	40.6	34.9	43.9	49.3	49.0	41.7	31.6	44.5	50.1
	S.C.	46.0	38.8	33.5	35.0	26.5	47.4	40.3	32.3	37.4	28.2	48.8	41.7	31.2	39.7	29.9
	K.W.	5.45	6.21	6.20	6.26	6.34	5.54	6.31	6.30	6.35	6.43	5.63	6.41	6.39	6.45	6.52

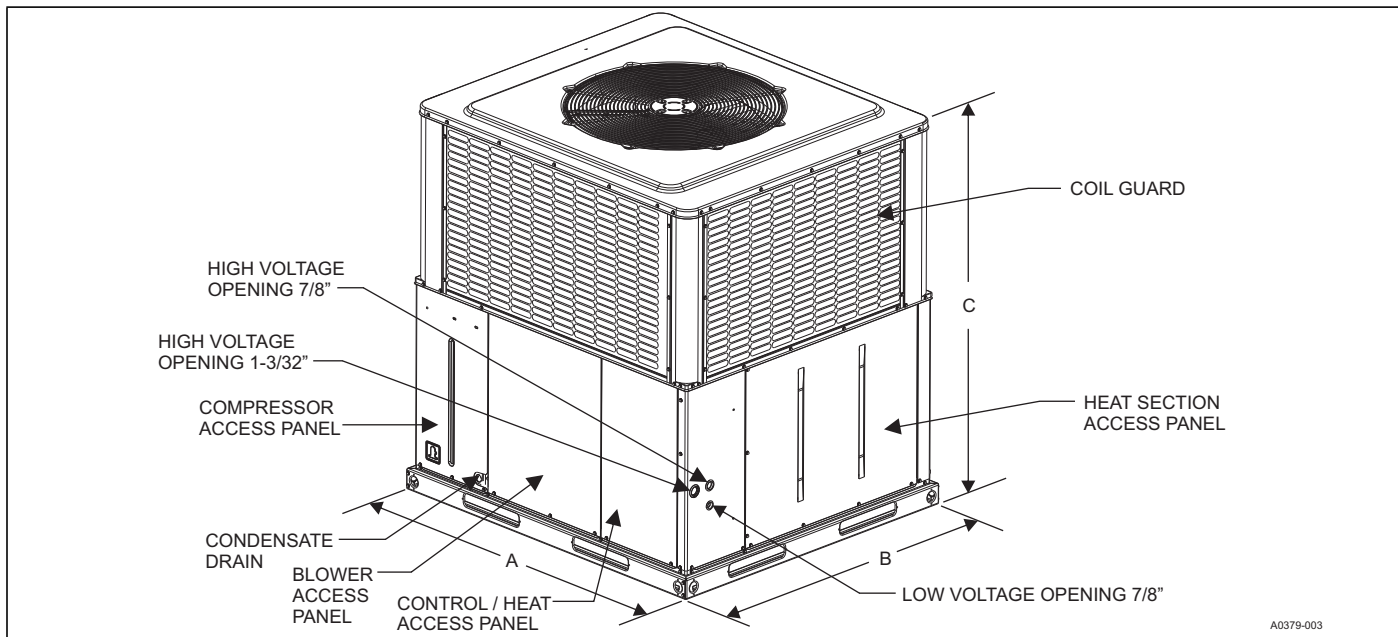

A0379-003

UNIT DIMENSIONS

Model	Dimensions (in.)		
	A	B	C
PCE6A2424	51 1/4	35 3/4	44
PCE6A3624	51 1/4	35 3/4	47
PCE6B4824	51 1/4	45 3/4	47
PCE6B6024	51 1/4	45 3/4	50

UNIT CLEARANCES

Direction	Distance (in.)	Direction	Distance (in.)
Top ¹	36	Right Side	36
Side Opposite Ducts	36	Left Side	24
Duct Panel	0	Bottom ^{2,3}	1

1. Provide a minimum clearance of 1 in. on all sides of the supply air duct for the first 3 ft of the duct for 20 kW and 25 kW heaters (0 in. thereafter). For all other heaters, make sure that there is 0-in. clearance on all sides for the entire length of the supply air duct.

2. Install units outdoors. Make sure that overhanging structures or shrubs do not obstruct the outdoor air discharge outlet.

3. You can install units on combustible materials made from wood or class A, B, or C roof covering materials if factory base rails are left in place as shipped.

Note: For units installed on a roof curb, you can reduce the minimum clearance between combustible roof curb material and the supply air duct from 1 in. to 1/2 in.

INDOOR BLOWER SPECIFICATIONS

Model	Motor				
	HP	RPM	EFF.	SF	Frame
PCE6A2424	1/2	Variable	0.8	1.0	48
PCE6A3624	1/2	Variable	0.8	1.0	48
PCE6B4824	3/4	Variable	0.8	1.0	48
PCE6B6024	1	Variable	0.8	1.0	48

SOUND PERFORMANCE

Model (Tons)	Sound Rating ¹ dB(A)	Octave Band Centerline Frequency (Hz)						
		125	250	500	1000	2000	4000	8000
PCE6A2424	71	75.4	69.0	68.7	66	62	59.0	55.1
PCE6A3624	75	73.8	73.1	73.3	71.0	66.1	61.0	54.9
PCE6B4824	73	77.3	73.1	69.4	69	63	60.8	53.5
PCE6B6024	75	79.5	72.1	68.9	72	66	63.5	60.9

1. Rated in accordance with AHRI Standard 270.

ELECTRICAL DATA FOR 208/230-1-60 SINGLE SOURCE POWER

Model	Compressor			OD Fan Motor FLA	Blower Motor FLA	Electric Heat Option					MCA ¹ (A)		Max Fuse ² or Breaker ³ Size		
	RLA	LRA	MCC			Heater Kit ⁴	Heater (kW)		Stages	Heater (A)		208	230	208	230
				208	230		208	230							
PCE6A24	10.2	55.2	15.9	0.8	3.8	none	--	--	--	--	--	17.3	17.3	25	25
						6HK16500506	3.6	4.4	1	17.3	19.2	26.4	28.7	30	30
						6HK16500806	5.8	7.1	1	27.7	30.7	39.4	43.1	40	45
						6HK16501006	7.2	8.8	1	34.7	38.3	48.1	52.7	50	60
PCE6A36	14.2	78.1	22.1	1.7	3.8	none	--	--	--	--	--	23.2	23.2	35	35
						6HK16500506	3.6	4.4	1	17.3	19.2	26.4	28.7	35	35
						6HK16500806	5.8	7.1	1	27.7	30.7	39.4	43.1	40	45
						6HK16501006	7.2	8.8	1	34.7	38.3	48.1	52.7	50	60
PCE6B48	17.1	109.0	26.6	1.7	5.4	none	--	--	--	--	--	28.4	28.4	45	45
						6HK16500506	3.6	4.4	1	17.3	19.2	28.4	30.7	45	45
						6HK16500806	5.8	7.1	1	27.7	30.7	41.4	45.1	45	50
						6HK16501006	7.2	8.8	1	34.7	38.3	50.1	54.7	60	60
						6HK16501506	10.8	13.2	2	52.0	57.5	71.8	78.6	80	80
PCE6B60	23.5	118.0	36.6	1.7	7.0	none	--	--	--	--	--	38.0	38.0	60	60
						6HK16500506	3.6	4.4	1	17.3	19.2	38.0	38.0	60	60
						6HK16500806	5.8	7.1	1	27.7	30.7	43.4	47.1	60	60
						6HK16501006	7.2	8.8	1	34.7	38.3	52.1	56.7	60	60
						6HK16501506	10.8	13.2	2	52.0	57.5	73.8	80.6	80	90
PCE6B60	23.5	118.0	36.6	1.7	7.0	6HK16502006	14.4	17.6	2	69.3	76.7	95.4	104.6	100	110

1. Minimum Circuit Ampacity.
2. Maximum Overcurrent Protection per standard UL 1995.
3. Fuse or HACR circuit breaker is field installed.
4. Single-Point Connection Kit required.

ELECTRICAL DATA FOR 208-1-60 MULTI SOURCE POWER

Model	Compressor			OD Fan Motor FLA	Blower Motor FLA	Electric Heat Option				Multi Source							
	RLA	LRA	MCC			Heater Kit	Heater (kW)	Stages	Heater (A)	208	208	208	208	208	208	208	208
				208	208												
Multi Source: Compressor Circuit and Heat Circuits						Multi Source: Circuit 1 Compressor Circuit Circuit 2 Heat Circuit 3 Heat Circuit 4 Heat				Circuit 1		Circuit 2		Circuit 3		Circuit 4	
						none	--	--	--	17.3	25	--	--	--	--	--	--
A24	10.2	55.2	15.9	0.8	3.8	6HK(0,1)6500506	3.6	1	17.3	17.3	25	21.7	25	--	--	--	--
						6HK(0,1)6500806	5.8	1	27.7	17.3	25	34.7	35	--	--	--	--
						6HK(0,1)6501006	7.2	1	34.7	17.3	25	43.3	45	--	--	--	--
						none	--	--	--	23.2	35	--	--	--	--	--	--
A36	14.2	78.1	22.1	1.7	3.8	6HK(0,1)6500506	3.6	1	17.3	23.2	35	21.7	25	--	--	--	--
						6HK(0,1)6500806	5.8	1	27.7	23.2	35	34.7	35	--	--	--	--
						6HK(0,1)6501006	7.2	1	34.7	23.2	35	43.3	45	--	--	--	--
						6HK16501506	10.8	2	52.0	23.2	35	21.7	25	43.3	45	--	--
						6HK26501506	10.8	2	52.0	23.2	35	65.0	70	--	--	--	--
B48	17.1	109.0	26.6	1.7	5.4	none	--	--	--	28.4	45	--	--	--	--	--	--
						6HK(0,1)6500506	3.6	1	17.3	28.4	45	21.7	25	--	--	--	--
						6HK(0,1)6500806	5.8	1	27.7	28.4	45	34.7	35	--	--	--	--
						6HK(0,1)6501006	7.2	1	34.7	28.4	45	43.3	45	--	--	--	--
						6HK16501506	10.8	2	52.0	28.4	45	21.7	25	43.3	45	--	--
						6HK16502006	14.4	2	69.3	28.4	45	43.3	45	43.3	45	--	--
						6HK26501506	10.8	2	52.0	28.4	45	65.0	70	--	--	--	--
6HK26502006	14.4	2	69.3	28.4	45	86.7	90	--	--	--	--						

ELECTRICAL DATA FOR 208-1-60 MULTI SOURCE POWER (Continued)

Model	Compressor			OD Fan Motor	Blower Motor	Electric Heat Option				Multi Source							
						Heater Kit	Heater (kW)	Stages	Heater (A)	208	208	208	208	208	208	208	208
	208	208															
Multi Source: Compressor Circuit and Heat Circuits						Multi Source: Circuit 1 Compressor Circuit Circuit 2 Heat Circuit 3 Heat Circuit 4 Heat				MCA ¹ (A)	Max Fuse ² or Breaker ³ Size	MCA ¹ (A)	Max Fuse ² or Breaker ³ Size	MCA ¹ (A)	Max Fuse ² or Breaker ³ Size	MCA ¹ (A)	Max Fuse ² or Breaker ³ Size
										Circuit 1		Circuit 2		Circuit 3		Circuit 4	
B60	23.5	118.0	36.6	1.7	7.0	none	--	--	--	38.0	60	--	--	--	--	--	
						6HK(0,1)6500506	3.6	1	17.3	38.0	60	21.7	25	--	--	--	--
						6HK(0,1)6500806	5.8	1	27.7	38.0	60	34.7	35	--	--	--	--
						6HK(0,1)6501006	7.2	1	34.7	38.0	60	43.3	45	--	--	--	--
						6HK16501506	10.8	2	52.0	38.0	60	21.7	25	43.3	45	--	--
						6HK16502006	14.4	2	69.3	38.0	60	43.3	45	43.3	45	--	--
						6HK16502506	18.0	2	86.7	38.0	60	43.3	45	43.3	45	21.7	25
						6HK26501506	10.8	2	52.0	38.0	60	65.0	70	--	--	--	--
						6HK26502006	14.4	2	69.3	38.0	60	86.7	90	--	--	--	--
6HK26502506	18.0	2	86.7	38.0	60	108.3	110	--	--	--	--						

1. MCA = Minimum Circuit Ampacity.
2. Maximum Overcurrent Protection per standard UL 1995.
3. Fuse or HACR circuit breaker is field installed.

ELECTRICAL DATA FOR 230-1-60 MULTI SOURCE POWER

Model	Compressor			OD Fan Motor	Blower Motor	Electric Heat Option				Multi Source							
						Heater Kit	Heater (kW)	Stages	Heater (A)	230	230	230	230	230	230	230	230
	230	230															
Multi Source: Compressor Circuit and Heat Circuits						Multi Source: Circuit 1 Compressor Circuit Circuit 2 Heat Circuit 3 Heat Circuit 4 Heat				MCA ¹ (A)	Max Fuse ² or Breaker ³ Size	MCA ¹ (A)	Max Fuse ² or Breaker ³ Size	MCA ¹ (A)	Max Fuse ² or Breaker ³ Size	MCA ¹ (A)	Max Fuse ² or Breaker ³ Size
										Circuit 1		Circuit 2		Circuit 3		Circuit 4	
A24	10.2	55.2	15.9	0.8	3.8	none	--	--	--	17.3	25	--	--	--	--	--	
						6HK(0,1)6500506	4.4	1	19.2	17.3	25	24.0	25	--	--	--	--
						6HK(0,1)6500806	7.1	1	30.7	17.3	25	38.3	40	--	--	--	--
						6HK(0,1)6501006	8.8	1	38.3	17.3	25	47.9	50	--	--	--	--
A36	14.2	78.1	22.1	1.7	3.8	none	--	--	--	23.2	35	--	--	--	--	--	
						6HK(0,1)6500506	4.4	1	19.2	23.2	35	24.0	25	--	--	--	--
						6HK(0,1)6500806	7.1	1	30.7	23.2	35	38.3	40	--	--	--	--
						6HK(0,1)6501006	8.8	1	38.3	23.2	35	47.9	50	--	--	--	--
						6HK16501506	13.2	2	57.5	23.2	35	24.0	25	47.9	50	--	--
6HK26501506	13.2	2	57.5	23.2	35	71.9	80	--	--	--	--						
B48	17.1	109.0	26.6	1.7	5.4	none	--	--	--	28.4	45	--	--	--	--	--	
						6HK(0,1)6500506	4.4	1	19.2	28.4	45	24.0	25	--	--	--	--
						6HK(0,1)6500806	7.1	1	30.7	28.4	45	38.3	40	--	--	--	--
						6HK(0,1)6501006	8.8	1	38.3	28.4	45	47.9	50	--	--	--	--
						6HK16501506	13.2	2	57.5	28.4	45	24.0	25	47.9	50	--	--
						6HK16502006	17.6	2	76.7	28.4	45	47.9	50	47.9	50	--	--
						6HK26501506	13.2	2	57.5	28.4	45	71.9	80	--	--	--	--
6HK26502006	17.6	2	76.7	28.4	45	95.8	100	--	--	--	--						
B60	23.5	118.0	36.6	1.7	7.0	none	--	--	--	38.0	60	--	--	--	--	--	
						6HK(0,1)6500506	4.4	1	19.2	38.0	60	24.0	25	--	--	--	--
						6HK(0,1)6500806	7.1	1	30.7	38.0	60	38.3	40	--	--	--	--
						6HK(0,1)6501006	8.8	1	38.3	38.0	60	47.9	50	--	--	--	--
						6HK16501506	13.2	2	57.5	38.0	60	24.0	25	47.9	50	--	--
						6HK16502006	17.6	2	76.7	38.0	60	47.9	50	47.9	50	--	--
						6HK16502506	22.0	2	95.8	38.0	60	47.9	50	47.9	50	24.0	25
						6HK26501506	13.2	2	57.5	38.0	60	71.9	80	--	--	--	--
6HK26502006	17.6	2	76.7	38.0	60	95.8	100	--	--	--	--						
6HK26502506	22.0	2	95.8	38.0	60	119.8	125	--	--	--	--						

1. MCA = Minimum Circuit Ampacity.
2. Maximum Overcurrent Protection per standard UL 1995.
3. Fuse or HACR circuit breaker is field installed.

ELECTRIC HEAT PERFORMANCE DATA

Heater Models ^{1,2}	Nominal kW at 240 V	Total Heat				kW Staging			
		kW		MBH		W1 Only		W1 + W2	
		208 V	230 V	208 V	230 V	208 V	230 V	208 V	230 V
6HK(0,1)6500506	4.8	3.6	4.4	12.3	15.0	3.6	4.4	3.6	4.4
6HK(0,1)6500806	7.7	5.8	7.1	19.7	24.1	5.8	7.1	5.8	7.1
6HK(0,1)6501006	9.6	7.2	8.8	24.6	30.1	7.2	8.8	7.2	8.8
6HK(1,2)6501506	14.4	10.8	13.2	36.9	45.1	3.6	4.4	10.8	13.2
6HK(1,2)6502006	19.2	14.4	17.6	49.2	60.2	7.2	8.8	14.4	17.6
6HK(1,2)6502506	24.0	18.0	22.0	61.5	75.2	7.2	8.8	18.0	22.0

- (0,1): 0 = no service disconnect or 1 = with service disconnect.
- (1,2): 1 = with service disconnect, no breaker jumper bar or 2 = with service disconnect and breaker jumper bar.

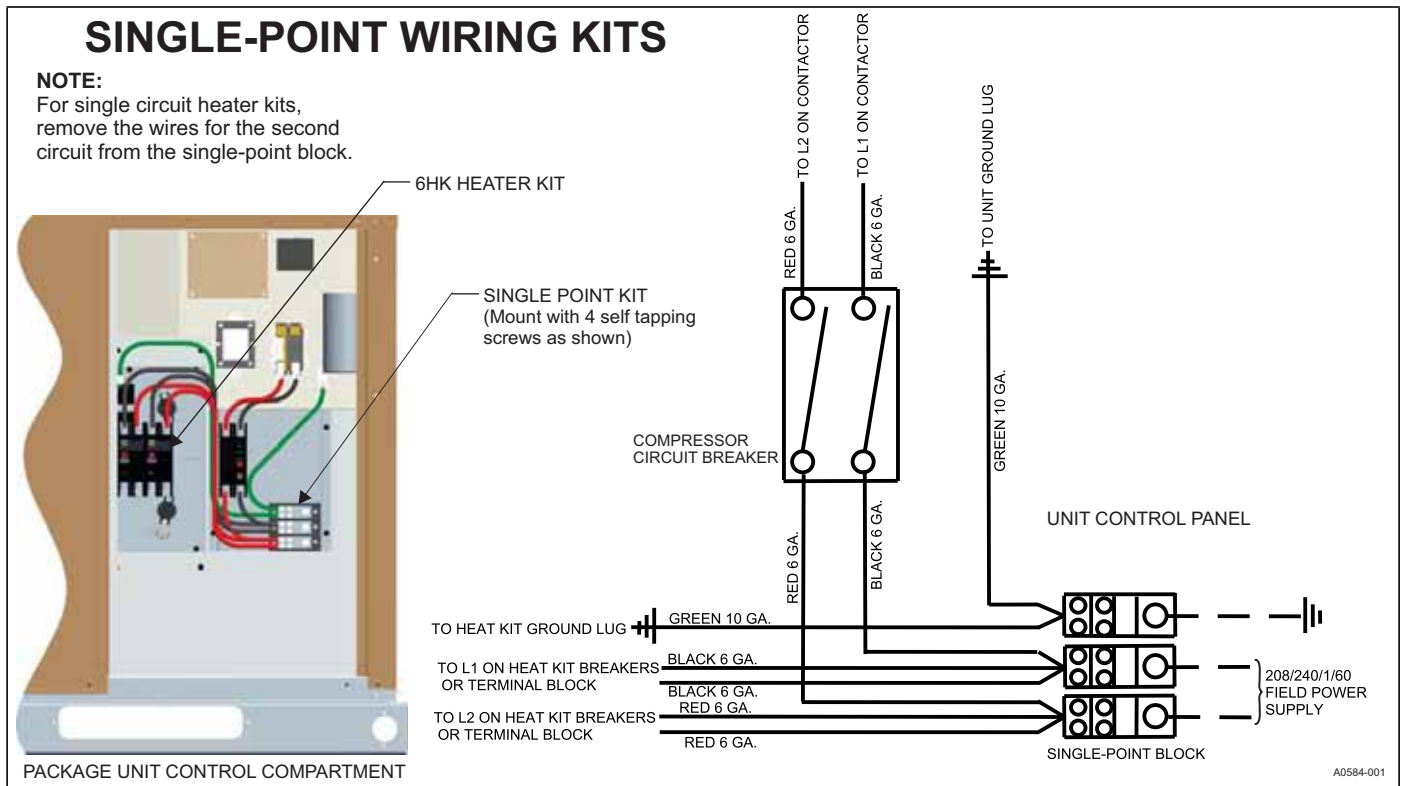

SINGLE-POINT WIRING KIT PART NUMBERS

Unit Model Number	Single-Point Kit Part Number	Breaker Size	Heat Kit
PCE6A24	S1-2SPWK006	25 A	Up to 10 kW
PCE6A36	S1-2SPWK002	35 A	Up to 15 kW
PCE6B48	S1-2SPWK003	45 A	Up to 20 kW
PCE6B60	S1-2SPWK005	60 A	Up to 20 kW

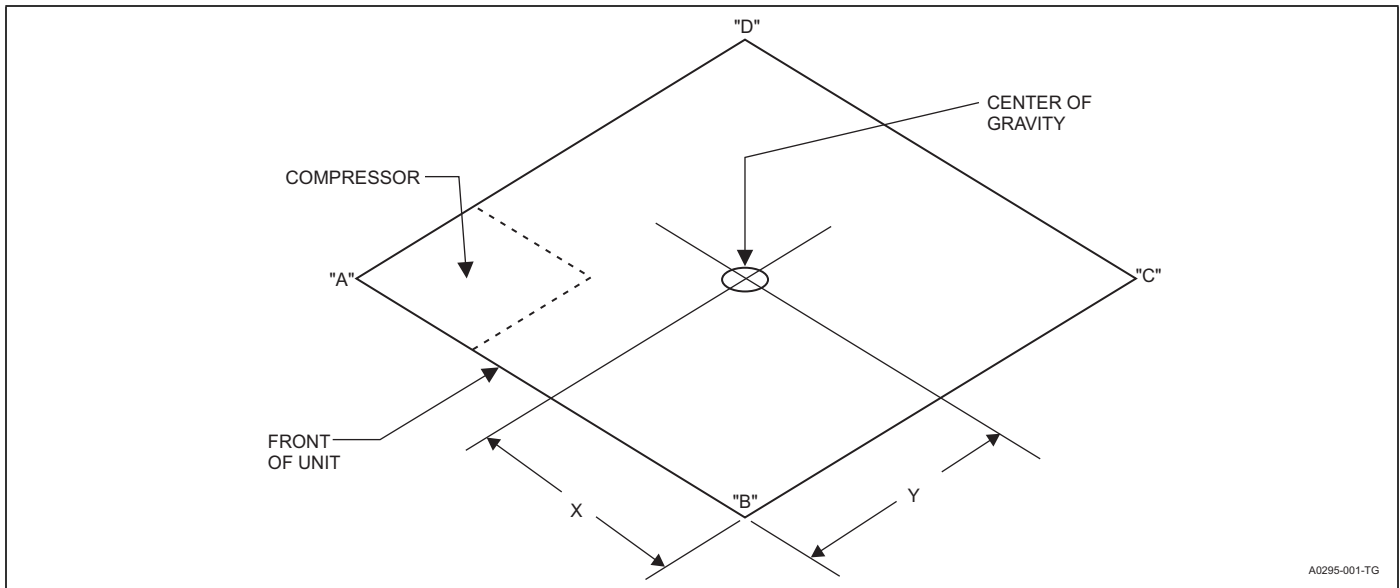

A0295-001-TG

WEIGHTS AND DIMENSIONS

Model	Weight (lb)		Center of Gravity		4-Point Load Location (lb)			
	Shipping	Operating	X	Y	A	B	C	D
PCE6A2424	348	343	30	15	96	105	107	40
PCE6A3624	466	461	32	13	167	131	130	38
PCE6B4824	488	483	30	19	158	125	130	75
PCE6B6024	505	500	30	20	157	134	140	74

MINIMUM BLOWER SPEED FOR ELECTRIC HEAT

Model	Heater (kW)					
	5	8	10	15	20	25
PCE6A2424	B (MH)	B (MH)	B (MH)	--	--	--
PCE6A3624	B (MH)	B (MH)	A (HI)	--	--	--
PCE6B4824	C (ML)	C (ML)	C (ML)	A (HI)	A (HI)	--
PCE6B6024	C (ML)	C (ML)	A (HI)	A (HI)	A (HI)	A (HI)

AIRFLOW PERFORMANCE - SIDE DUCT APPLICATION

Model	Jumper Position		External Static Pressure (in. W.C.)									
			0.1	0.2	0.3	0.4	0.5	0.6	0.7	0.8	0.9	1.0
			SCFM	SCFM	SCFM	SCFM	SCFM	SCFM	SCFM	SCFM	SCFM	SCFM
PCE6A24	High Cool	A	1030	990	960	930	900	860	820	780	740	680
		B	910	870	840	810	770	730	680	620	570	540
		C	730	690	660	610	560	490	450	400	360	310
		D	820	790	750	710	670	610	570	510	470	430
	Low Cool	A	820	790	750	710	670	610	570	510	470	430
		B	730	690	660	610	560	490	450	400	360	310
		C	580	550	500	440	390	350	290	240	180	130
		D	410	380	350	310	270	240	200	160	120	90
	Heat	A	1050	1020	990	960	930	890	850	820	770	720
		B	840	800	770	730	680	630	590	530	490	450
		C	580	550	500	440	390	350	290	240	180	130
		D	290	270	250	220	200	170	150	120	90	60
PCE6A36	High Cool	A	1340	1300	1270	1230	1190	1140	1090	1040	990	940
		B	1250	1210	1170	1130	1090	1030	980	930	880	840
		C	1010	970	920	860	800	750	700	660	610	570
		D	1160	1120	1080	1040	990	930	880	830	780	740
	Low Cool	A	1080	1040	990	940	880	830	780	730	680	640
		B	960	910	860	790	740	690	640	590	550	510
		C	830	770	690	640	590	540	490	430	380	320
		D	760	700	620	570	510	460	410	340	280	220
	Heat	A	1120	1080	1030	990	930	870	820	770	730	690
		B	1030	980	930	880	820	770	710	670	630	580
		C	830	770	690	640	590	540	490	430	380	320
		D	710	640	560	510	450	390	340	260	190	130
PCE6B48	High Cool	A	1890	1860	1810	1780	1750	1710	1660	1620	1580	1550
		B	1780	1740	1700	1660	1620	1580	1540	1500	1450	1410
		C	1500	1450	1410	1370	1320	1270	1230	1180	1130	1070
		D	1700	1660	1620	1580	1540	1500	1460	1420	1380	1330
	Low Cool	A	1500	1450	1410	1370	1320	1270	1230	1180	1130	1070
		B	1480	1440	1390	1350	1300	1260	1210	1170	1110	1050
		C	1430	1380	1340	1290	1240	1190	1140	1100	1040	970
		D	1370	1320	1280	1230	1180	1130	1080	1020	970	900
	Heat	A	1530	1490	1440	1400	1360	1310	1270	1220	1170	1110
		B	1410	1360	1320	1270	1220	1170	1120	1070	1020	950
		C	1250	1200	1150	1100	1050	990	930	870	820	750
		D	1140	1090	1040	980	930	860	790	730	670	610
PCE6B60	High Cool	A	2120	2080	2050	2020	1980	1940	1900	1870	1830	1800
		B	2040	2000	1970	1930	1890	1860	1820	1780	1740	1710
		C	1740	1710	1670	1630	1600	1560	1520	1490	1450	1410
		D	1930	1900	1870	1830	1790	1760	1710	1680	1640	1600
	Low Cool	A	1650	1610	1570	1530	1490	1460	1420	1380	1340	1300
		B	1540	1500	1460	1420	1380	1340	1300	1260	1220	1170
		C	1500	1460	1420	1380	1330	1300	1260	1210	1170	1120
		D	1450	1400	1360	1310	1270	1230	1180	1130	1080	1030
	Heat	A	1770	1740	1700	1660	1630	1590	1550	1520	1480	1440
		B	1480	1440	1400	1360	1310	1280	1230	1190	1140	1090
		C	1410	1360	1320	1270	1220	1190	1130	1080	1030	970
		D	1250	1200	1150	1100	1040	990	930	880	810	760

Notes:

Airflow tested with dry coil conditions, without air filters, at 230 V.

Applications above 0.8 in. W.C. external static pressure are not recommended.

Brushless DC high efficiency enhanced ECM blower motor is used for all indoor blower assemblies.

Minimal variations in airflow performance data result from operating at 208 V. The data in the table can be used in those cases.

Heating applications are tested at 0.50 in. W.C. external static pressure. Cooling applications are tested per AHRI Standard 210/240.

The differences between side duct airflows and bottom duct airflows are insignificant.

ADDITIONAL STATIC RESISTANCE

Size (Tons)	CFM	Wet Indoor Coil	Economizer ¹	Filter/Frame Kit
24 (2.0)	500	0.01	0.00	0.01
	600	0.01	0.00	0.02
	700	0.01	0.00	0.04
	800	0.02	0.01	0.06
	900	0.03	0.01	0.08
	1000	0.04	0.01	0.10
	1100	0.05	0.01	0.13
	1200	0.06	0.02	0.16
36 (3.0)	700	0.01	0.00	0.04
	800	0.02	0.01	0.06
	900	0.03	0.01	0.08
	1000	0.04	0.01	0.10
	1100	0.05	0.01	0.13
	1200	0.06	0.02	0.16
	1300	0.07	0.03	0.17
	1400	0.08	0.04	0.18
48 (4.0)	1100	0.02	0.02	0.04
	1200	0.03	0.02	0.04
	1300	0.04	0.02	0.05
	1400	0.05	0.03	0.05
	1500	0.06	0.04	0.06
	1600	0.07	0.04	0.07
	1700	0.07	0.04	0.08
	1800	0.08	0.04	0.09
	1900	0.09	0.05	0.10
	2000	0.09	0.05	0.11
60 (5.0)	1100	0.02	0.02	0.04
	1200	0.03	0.02	0.04
	1300	0.04	0.02	0.05
	1400	0.05	0.03	0.05
	1500	0.06	0.04	0.06
	1600	0.07	0.04	0.07
	1700	0.07	0.04	0.08
	1800	0.08	0.04	0.09
	1900	0.09	0.05	0.10
	2000	0.09	0.05	0.11

1. The pressure drop through the economizer is greater for 100% outdoor air than for 100% return air. If the resistance of the return air duct is less than 0.25 IWG, the unit delivers less CFM during full economizer operation.
Note: Filter pressure drop based on standard filter media tested at velocities not to exceed 300 ft/min.

BOTTOM DUCT DIMENSIONS (in.)

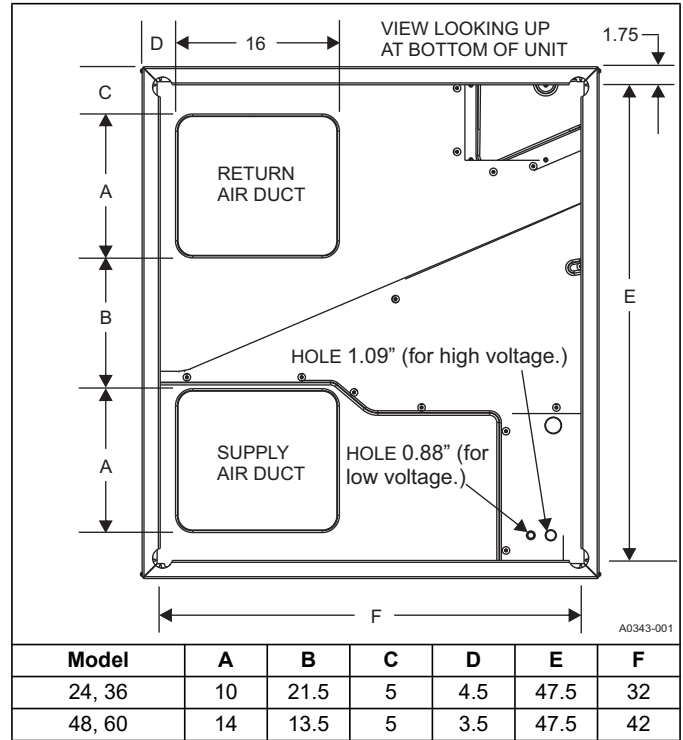

REAR DUCT DIMENSIONS (in.)

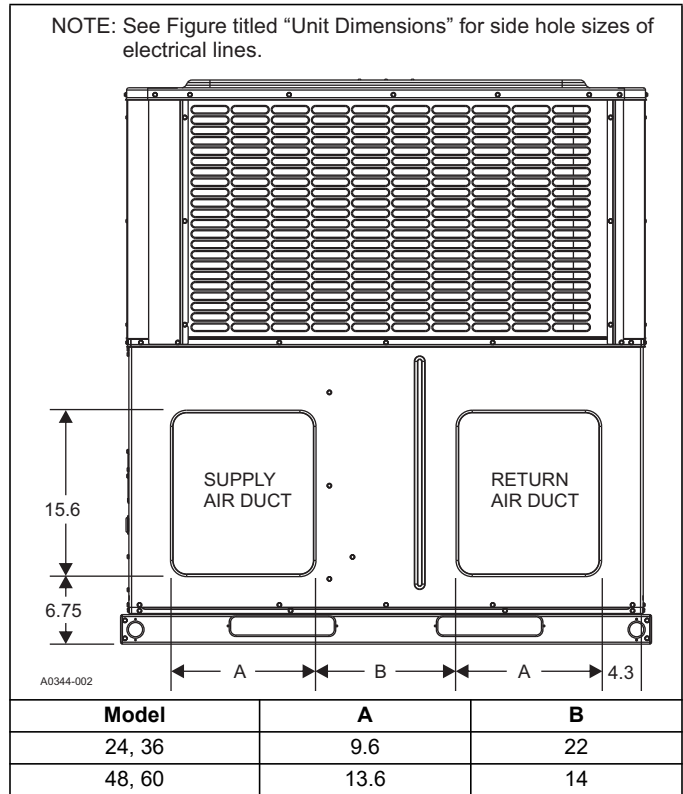

UNIT TYPICAL DUCT APPLICATIONS

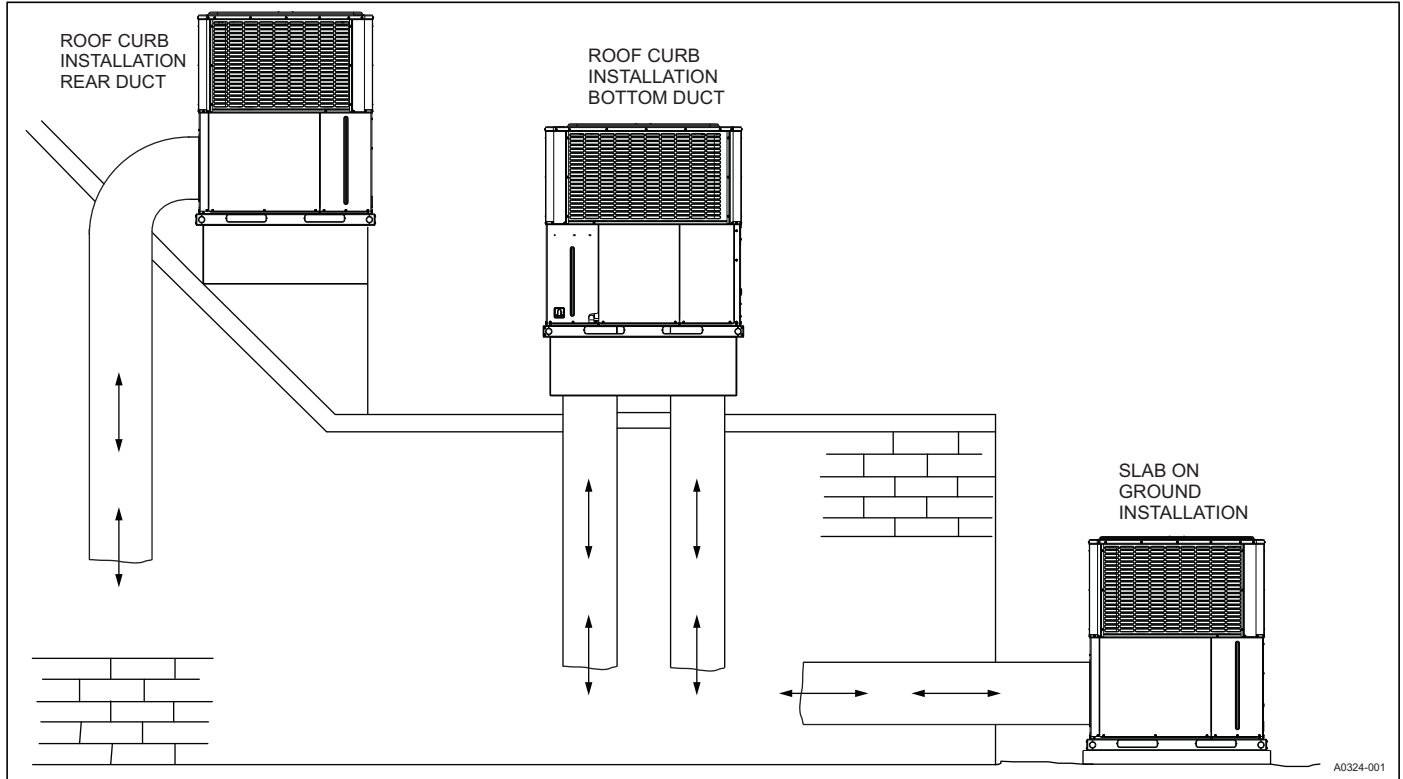

UNIT TYPICAL SLAB ON GROUND INSTALLATION

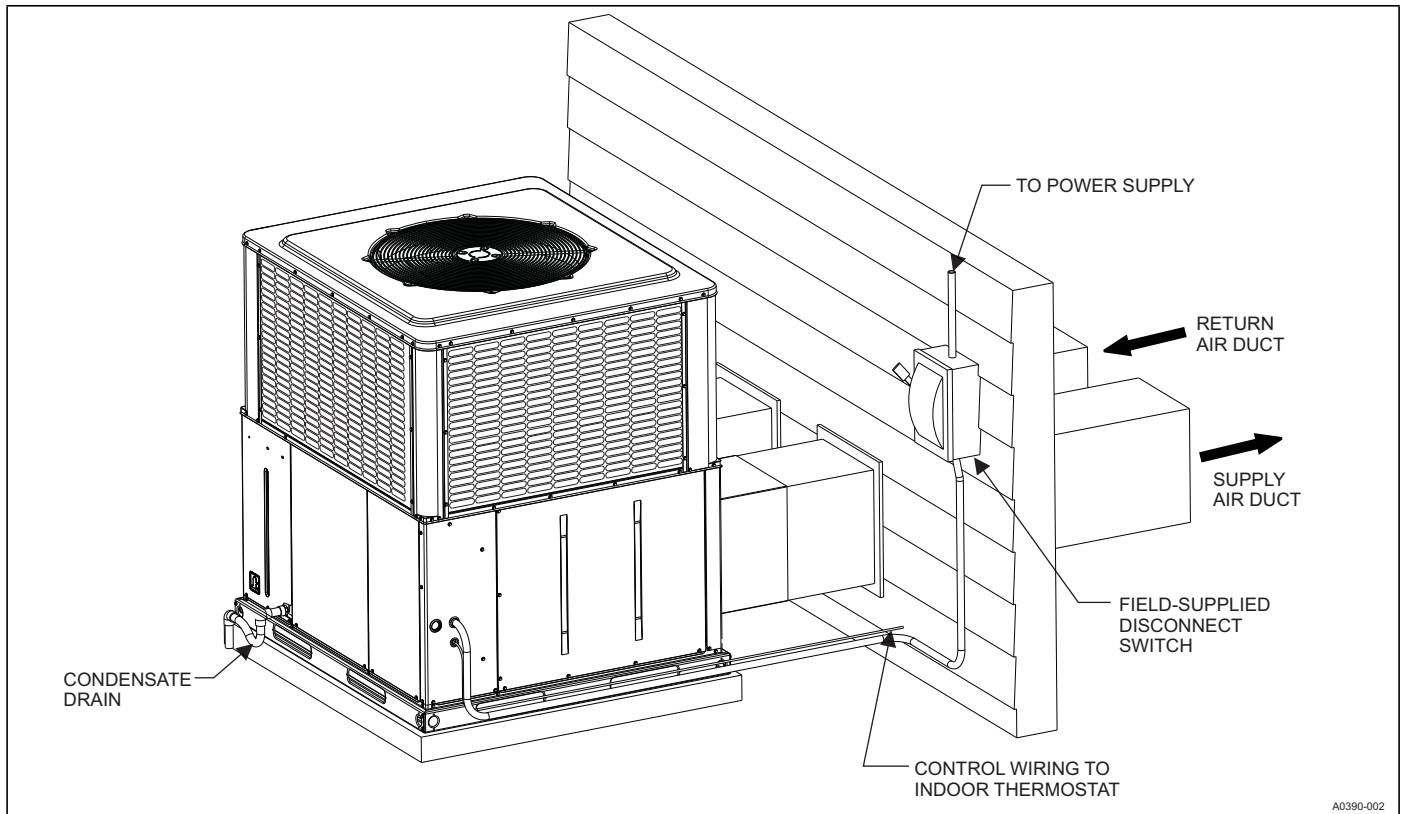

UNIT TYPICAL ROOF CURB INSTALLATION

