

---

# Residential Single Stage Gas Furnace

---

Field Reference Guide  
Updated July 2023

# Table of Contents

---

Introduction	3
Safety	8
Component Familiarization	15
Installation	31
Start-up	50
Sequence of Operation	57
Troubleshooting	63
Maintenance	86

01

---

# Introduction

# Introduction

---

## Single Stage Defined

A single stage gas furnace operates at a single firing rate. Upon a call for heat and furnace ignition, the rated BTUH output capacity is delivered. When the call for heat expires, the heating output ceases.

## Available 33" Single Stage Furnace Models

The 33" single stage gas furnace is available in two major models:

- 80% single stage and
- 95%+ single stage

# Single Stage 80%

---

## Features

- Easily applied in up flow, horizontal left or right, or downflow installation with minimal conversion necessary.
- Compact, easy to install, ideal height 33" tall cabinet.
- Easy access to controls to connect power/control wiring.
- Built-in, high level self-diagnostics with fault code displays standard on integrated control module for reliable operation.
- Low unit amp requirement for easy replacement application.
- All models are convertible to use propane (LP) gas.
- Electronic Hot Surface Ignition saves fuel cost with increased dependability and reliability.
- 100% shut off main gas valve for extra safety.
- 5 speed direct drive, Standard ECM high efficiency DC motor with blower off delay for lower electrical power usage and improved cooling SEER ratings.
- 24V, 40 VA control transformer and blower relay supplied for add-on cooling.
- Hi-tech tubular aluminized steel primary heat exchanger.
- Timed on, adjustable off blower capability for maximum comfort.
- Blower door safety switch.
- Solid removable bottom panel allows easy conversion.
- Low NOx models have been designed to meet specific code requirements.
- Airflow leakage less than 1% of total airflow at duct blaster conditions.
- No knockouts to deal with, making installation easier.
- Movable duct connector flanges for application flexibility.
- Quiet inducer operation.
- Inducer rotates for easy conversion of venting options.
- Slide Out blower assembly for easy access and removal of blower.
- External air filters used for maximum flexibility in meeting customers' IAQ needs.
- Venting applications - may be installed as a common vent with other gas-fired appliances or use a masonry chimney.
- 1/4 turn knobs provided for easy door removal.
- Insulated blower compartment for thermal and acoustic performance.



# Single Stage 95%

## Features

- Easily applied in up flow, horizontal left or right, or downflow installation with minimal conversion necessary.
- Compact, easy to install, ideal height 33" tall cabinet.
- Blower-off delay for cooling SEER improvement.
- Easy access to controls to connect power/control wiring.
- Built-in, high level self-diagnostics with fault code displays standard on integrated control module for reliable operation.
- Low unit amp requirement for easy replacement application.
- All models are convertible to use propane (LP) gas.
- Electronic Hot Surface Ignition saves fuel cost with increased dependability and reliability.
- 100% shut off main gas valve for extra safety.
- 5 speed, direct drive Standard ECM style high efficiency DC motor.
- 24V, 40 VA control transformer and blower relay supplied for add-on cooling.
- Hi-tech tubular aluminized steel primary heat exchanger.
- Secondary heat exchanger made of corrosion resistant stainless-steel materials.
- Timed on, adjustable off blower capability for maximum comfort.
- Blower door safety switch.
- Solid removable bottom panel allows easy conversion.
- Airflow leakage is less than 1% of nominal airflow at duct blaster conditions.
- No knockouts to deal with, making installation easier.
- Movable duct connector flanges for application flexibility.
- Quiet inducer operation.
- Inducer rotates for easy conversion of venting options.
- Fully supported blower assembly for easy access and removal of blower.
- External air filters used for maximum flexibility in meeting customers' IAQ needs.
- Protection included from air intake, exhaust vent, or condensate blockage.
- Patent pending self-priming internal condensate trap design for easy installation.
- Venting applications - may be installed as either a 2-pipe (sealed combustion) or a single-pipe vent (using indoor combustion air).
- No special vent termination required.
- 1/4 turn knobs provided for easy door removal.
- High-efficiency blower motor for lower electrical power usage and improved A/C SEER ratings.
- Insulated blower compartment for terminal and acoustic performance.



## No External Trap

The 95% AFUE 33" furnaces use an innovative four-way collector box at the exit of the secondary heat exchanger. The design of the collector box eliminates the necessity of an external drain trap for the secondary heat exchanger. The collector box allows condensate drainage in any of the four installation configurations.



Four-Way Collector Box

## No Burner Box

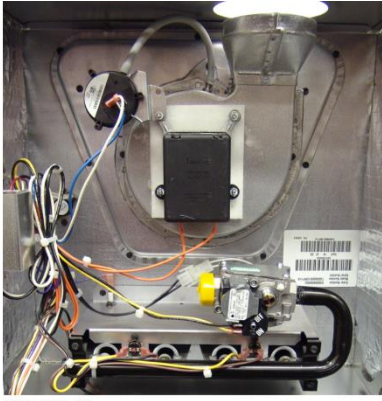

80% AFUE Model Vestibule

The burner access panel seals to the cabinet, allowing “sealed combustion” operation without a traditional “burner box”. Components that are normally confined within a burner box, such as the burners, flame sensor, hot surface ignitor, and rollout switches are easily accessible.

02

---

# Safety



## Safety Symbols

---

Reminder – use this guide in conjunction with the technical literature for each product. This guide does not supersede the Installation Manual and technical Guide provided with the equipment. Always read and follow all instructions before installing equipment. Understand and pay particular attention to the signal words **DANGER**, **WARNING**, or **CAUTION**.

**DANGER** indicates an imminently hazardous situation which could result in death or serious injury.

 <b>DANGER</b>
An overpressure protection device, such as a pressure regulator, must be installed in the gas piping system upstream of the furnace and must act to limit the downstream pressure to the gas valve so it does not exceed 0.5 psig [14" w.c. (3.48 kPa)]. Pressures exceeding 0.5 psig [14" w.c. (3.48 kPa)] at the gas valve will cause damage to the gas valve, resulting in a fire or explosion or cause damage to the furnace or some of its components that will result in property damage and loss of life.

**WARNING** indicates a potentially hazardous situation which could result in death or serious injury.

 <b>WARNING</b>
The duct system must be properly sized to obtain correct airflow for the furnace size that is being installed. Refer to the furnace rating plate for the correct rise range and static pressures. If the ducts are undersized, the result will be high duct static pressures and/ or high temperature rises which can result in a heat exchanger OVERHEATING CONDITION. This condition can result in premature heat exchanger failure, which can result in personal injury, property damage, or death.

**CAUTION** indicates a potentially hazardous situation, which, if not avoided, may result in minor or moderate injury. It is also used to alert against unsafe practices and hazards involving only property damage.

 <b>CAUTION</b>
The indoor coil must be installed in the supply air duct, downstream of the furnace. Cooled air may not be passed over the heat exchanger.

## Safety Specific Rules

---

Follow these specific safety rules for a safe application:

Ducted Systems gas furnaces use natural gas or propane (LP) gas as approved fuels. LP applications require installation of the appropriate LP conversion kit. Refer to the package unit rating plate or Installation Manual for information on proper inlet and manifold pressures.

Install gas furnaces only in a location and position as specified in the Installation Manual.

Provide adequate clearances for service, combustion, and ventilation air to the package unit when natural gas or propane (LP) gases are the fuels utilized for heating. The recommended clearances should be specified in the Installation Manual.

Test for gas leaks as specified in the Installation Manual.

Only connect the equipment to a duct system which has an external static pressure within the allowable range as specified in the Installation Manual and on the equipment rating plate.

Ducted Systems gas furnaces are not to be used for temporary heating or cooling of buildings or structures under construction. Improper installation will shorten equipment life, reduce product efficiency, and void the warranty. Always install the system to operate within the equipment's intended temperature and operating ranges.

The size of the unit should be based on an acceptable and approved heat load calculation for the structure being conditioned.



# Safety Requirements

Follow these safety requirements for a safe application:

- All equipment should be installed in accordance with all national and local building/safety codes and requirements, local plumbing or wastewater codes, and other applicable codes. In the absence of local codes, install in accordance with the most recent National Electrical Code, National Fuel Gas Code, and/or Natural Gas and Propane Installation Code (latest editions). Furnaces have been certified to the latest edition of standard ANSI and CSA standards.
- Refer to the unit rating plate for the equipment model number and refer to the Installation Manual for proper air plenum dimensions.
- Provide clearances from combustible materials as listed under Clearances to Combustibles in the Installation Manual and the equipment rating plate.
- Provide clearances for servicing ensuring that service access is allowed for both the burners and indoor fan motor.

## Important

Failure to carefully read and follow all instructions in this Guide and the equipment Installation Manual can result in equipment malfunction, death, personal injury and/or property damage.

Check the rating plate and power supply to be sure that the electrical characteristics match. All Unitary Products residential gas furnaces use a 120-volt AC 60-Hertz power supply. **DO NOT CONNECT TO A 50 HZ POWER SUPPLY OR A VOLTAGE OTHER THAN THE RANGE SPECIFIED ON THE UNIT DATA TAG.**

The equipment shall be installed so the access panels are readily available, and the electrical components are protected from water infiltration.

Installing and servicing HVAC equipment can be hazardous due to the electrical and mechanical components. Only trained and qualified personnel should install, repair, or service HVAC equipment. When working on equipment, observe precautions in the manuals and on the labels attached to the unit and other safety precautions that may apply.

The Installation Manual covers minimum requirements needed to conform to existing national standards and safety codes. In some instances, these instructions exceed certain local codes and ordinances. These instructions are required as a minimum for safe installation and operation. Always thoroughly read and understand the Installation Manual for the product being installed or serviced.

# INSTALLATION MANUAL

Single Stage ECM Residential Gas Furnaces

Models: TM8E, TMLE

(80% Multi-Position/Standard and Low NOx)



### List of sections

Safety	1	Start-up and adjustments	16
Ductwork	5	Safety controls	22
Filters	8	Replacement parts list	24
Gas piping	9	Replacement part contact information	24
Electrical power	11	Wiring diagram	25
Twining and staging	13	Start-up sheet	27
Vent system	13		

### List of figures

Duct attachment	5	Thermostat chart - single stage AC with single stage furnaces	12
Furnace and coil attachment	6	Thermostat chart - single stage HP with single stage furnaces	12
Combustible floor base accessory	6	Twinned furnaces	13
Horizontal application	6	Combustion air inducer	13
Typical attic installation	7	Combustion airflow path through the furnace casing to the burner compartment	14
Typical suspended furnace/crawl space installation	7	Ambient combustion air	15
Dimensions	8	Gas valve	19
Side return cutout markings	9	Reading gas pressure	19
Gas valve	9	Furnace control board	20
Gas piping	9	Wiring diagram	25
Electrical wiring	11		

### List of tables

Unit clearances to combustibles - all surfaces identified with the unit in an upflow configuration	4	Unconfined space minimum area	14
Cabinet and duct dimensions	8	Free area	15
Recommended filter sizes (high velocity 600 FPM)	8	Gas rate (ft <sup>3</sup> /h)	18
Nominal manifold pressure	10	Inlet gas pressure range	18
Ratings and physicalelectrical data	11	Nominal manifold pressure	19
Estimated free area	14	Default blower speeds	19
		Blower performance CFM - any position (without filter)	21

## General Awareness

Safety is ALWAYS the primary concern for everyone. On the job injuries can be significantly reduced when proper guidelines are followed. Always be aware of all company, local, state and/or OSHA (Occupational Safety and Health Administration) regulations.

## Jobsite Safety

Keeping the job site clean of trash, extra tools and equipment will significantly reduce the chance of injuries. Since each job is unique and has its own hazards, all new workers to the area should be made aware of the location of fire and first-aid equipment, fire escape routes, and other dangers.

## Hazardous Materials

Many different chemicals and compounds are used in the service and installation of HVAC systems. Please read the directions and use caution along with PPDs whenever handling these materials. Read and understand the MSDS for all materials used.

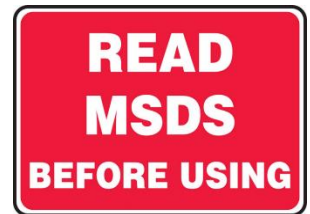

## Confined Spaces

Never enter or work in a confined space without taking the appropriate precautions. Have someone available outside the space ready to assist or summon help if necessary. Spaces that seem relatively safe can quickly become hazardous if a pipe were to break and fill the space with refrigerant, steam, poisonous fumes or other gases. Welding or brazing in a confined space is especially hazardous.

## Pressure

High pressures have always been part of the HVAC profession. Wear the proper personal protective devices including safety glasses and gloves. Proper hose ratings and manifolds are required for high pressure refrigerants.



## Electrical Safety

Jewelry should be removed prior to any electrical work being performed. Ensure that the equipment disconnect switch removes the primary power source prior to taking resistance readings or disconnecting any wires or connections. Removal of system power should be verified with the voltage function of a multimeter. All electrical safety guidelines should be always followed. Only trained, qualified technicians should perform electrical maintenance, installation, inspections and troubleshooting of electrical equipment.

Electrocution occurs when a current as low as 6 to 200mA flows through the heart, disrupting its normal operation and causing death. Electrical shock is an injury that occurs because of exposure to an electrical current. Inspect all extension cords and power tools regularly.

Fuses and circuit breakers are designed to protect equipment, not people. For personal electrical protection, GFCI or Ground Fault Circuit Interrupters are highly recommended.

## Lock-Out Tag-Out

OSHA Standards cover the servicing and maintenance of machines and equipment, in which unexpected energizing or startup of the machines or equipment, or release of stored energy, could cause injury to employees.

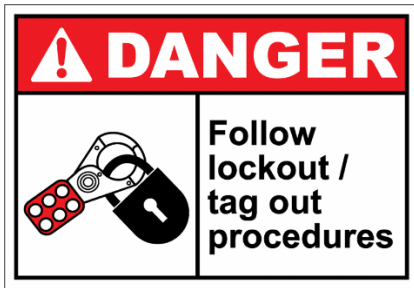

These standards establish minimum requirements for the control of such hazardous energy. To ensure safety, put a lock that is tagged with the technician's name on the electrical disconnect or breaker of the equipment or circuit which is being serviced.

Be aware of others who may be working on the same circuit or other circuits served by the same electrical panel. The technician should also be aware that other technicians may not have used the proper Lock-Out, Tag-Out procedures.

## Fire Safety and Burns

While brazing, keep the area clear of combustible material or use a heat shield to help reduce the risk of fire.

Check equipment regularly and never try to modify or repair regulators.

When servicing the refrigeration circuit, improper use of equipment and tools can result in serious burns that are associated with refrigerants. This may include frostbite, which is a deep tissue injury. Proper personal protection devices must be in use when servicing the refrigeration system.

## Personal Safety

Personal safety always includes remaining aware of the surroundings, using properly maintained tools, and correct use of items designed for personal protection.

### Personal Protection Devices (PPD):

- Hard Hat: Hard hats must be worn when there is a danger of head injury.
- Safety Glasses: Eye protection should be always worn while on a job site.
- Gloves: Assist in the prevention of serious injury to the hands from serious cuts as well as injuries from high pressure gases such as refrigerants. Rubber gloves can protect the technician's hands from chemicals when inspected and worn properly.
- Safety Shoes: Work shoes with steel toes for foot protection. There are also electrical safety shoes that can aid in protecting the technician against electrical shock and/or electrocution. At a minimum, leather work shoes with rubber soles are required.
- Respirator: Used in a confined space where the air can be dissipated by refrigerant which can cause asphyxiation.
- Safety Harness: Used when working above grade level. Ladders must be tied down. Ensure that PPDs provide the intended protection. They should be inspected regularly, used properly and never altered or modified in any way.



## Clothing

Rotating and moving components pose a serious risk. Loose-fitting clothing and ties should not be worn when servicing rotating equipment. If any clothing becomes entangled in moving parts, serious injury or death is a likely result.



## Jewelry

Serious injury or death can result if jewelry comes in contact with an energized circuit or is caught in moving parts. Leave jewelry at home or in your service bag or service vehicle.

## Lifting

To avoid back injuries, always adhere to proper lifting techniques. Be aware of personal limitations and seek help with items that are too heavy to safely lift. A back support belt may provide additional protection.



03

---

# Component Familiarization

## Primary Heat Exchanger

---

The tubular aluminized steel primary heat exchanger transfers heat from the products of combustion (inside the tubes) to the air circulated to the home (passing outside the tubes). Higher heating capacity models contain a greater quantity of primary heat exchanger tubes. One primary heat exchanger tube is present for each burner.

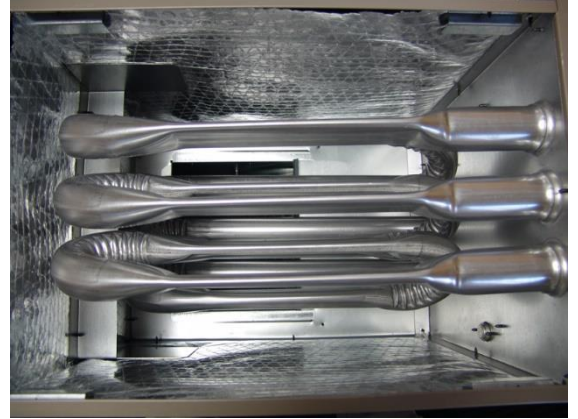

**Primary Heat Exchanger (80% AFUE Model)**



## Secondary Heat Exchanger (95% Models)

---

The secondary (condensing) heat exchanger is constructed with high-grade stainless steel. It is designed to extract additional heat from the products of combustion. This additional heat reduction reduces the temperature of the flue gasses below their dew point, causing the moisture in the flue gas to condense. The moisture is drained away through the collector box and condensate tubing. The tubes of the secondary heat exchanger contain turbulator strips, which cause the flue products to contact more of the internal surface of the secondary heat exchanger tubes. This allows additional heat to be extracted from the flue products prior to exiting the furnace.



## Gas Valve

During the heating sequence, the gas valve provides regulated control of the gas flow after the ignitor warmup period. The gas valve is energized with 24 volts AC to start the flow of gas to the burners. The gas valve is de-energized (stopping the gas flow) when the heating sequence is complete (or earlier, if a condition exists within the system that may create a safety or performance issue).

The gas valve on the 33" single stage gas furnace is shipped for use with natural gas. If LP gas use is required, the appropriate LP gas conversion kit must be installed and set up prior to furnace operation.

The manifold gas pressure, adjustable at the gas valve, must ALWAYS be properly set up during furnace installation and verified during service. For detailed information, see the Start-up section of this Guide.

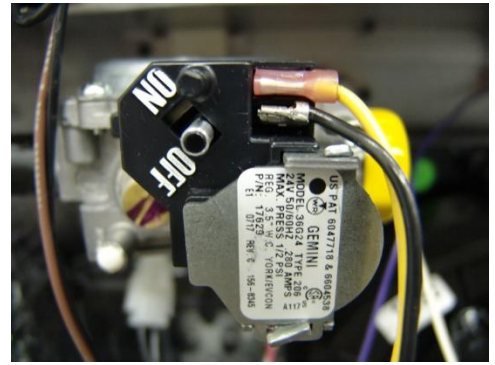

## Burner Orifice

---

The burner orifices guide the flow of gas from the manifold into the burner. Ducted Systems gas furnaces are shipped with natural gas orifices. When LP gas is used, the natural gas orifices must be replaced with LP gas orifices, following the instructions provided in the LP gas conversion kit for the furnace model used.

Orifices must be threaded straight into the manifold, with each orifice inserted into the manifold the same number of turns.

The orifice size is stamped on the body of the orifice. Always use factory-supplied orifices - do not attempt to modify the orifice size if converting from LP back to natural gas.



## Burners

---

The 33" single stage gas furnaces use in-shot burners, which require no air adjustment and are easy to maintain.

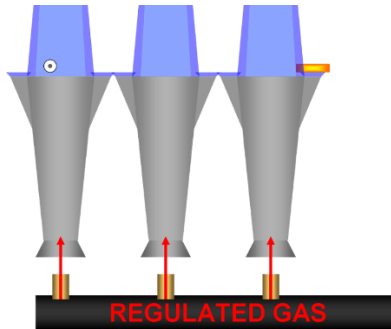

## **Manifold, Orifices, Burners**

---

After the gas moves through the manifold and orifices, it mixes with combustion air in the burner assembly. The gas and air are mixed in the throat of the burner and are directed out to the opposite end where the gas, air, and ignition source combine to create flame.

Inshot burners have a flame carryover channel that is built into each burner. This is how the flame spreads from burner to burner. The channel must remain clean and unobstructed for proper operation. If it is restricted, delayed ignition can result. Clean with a wire brush and maintain the flame carryover channel.

## Hot Surface Ignitor

---

During a trial for ignition, the silicon nitride hot surface ignitor is energized with 120 volts AC by the furnace control board (terminals 2 and 4 on the 4-pin plug connector). The ignitor will glow orange hot. At the end of the warm-up period, the furnace control board energizes the gas valve, allowing gas to flow to the burners. When the gas comes in contact with the hot surface ignitor, the gas ignites.



As with all hot surface ignitors, care should be used when handling. The resistance of the ignitor (when cold) should be between 40 and 80 Ohms.

The HSI is removed by disconnecting the plastic plug connector and removing one Philips head screw. The HSI will drop straight down out of the burner area.

## Flame Sensor

---

The 33" single stage gas furnaces use flame rectification for flame proving. The control board energizes the flame sensor with 120 volts AC. This AC input is rectified through the flame to DC.



A flame current pad is built into the furnace control board for flame signal measurement. This pad allows the technician to measure the flame current using a DC voltmeter. 1 volt DC = 1  $\mu$ A (microamp).

Under normal conditions, approximately 3.7 volts DC (3 volts DC, which equals 3.7 microamps) should be measured at the flame current pad. The furnace control board requires at least .1 volts DC (.1 microamps) to allow the heating cycle to continue.

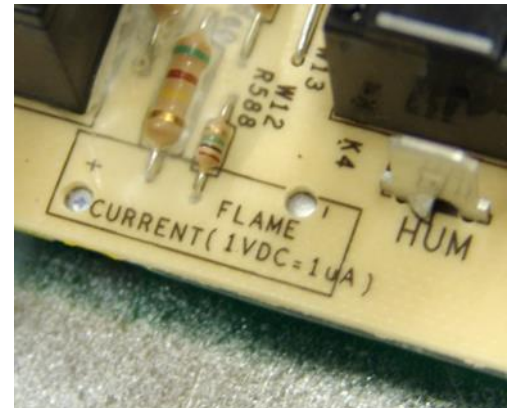

## Blower Motor (PSC) \*Legacy Models

PSC motors blower speeds are selectable with the blower speed tap connections on the furnace control board. The speeds for heating, cooling and continuous fan must be selected in the field. Only one blower speed may be energized at any time. The heating speed is selected to allow the temperature rise to fall within the range started on the unit rating plate. The cooling speed is selected to match the capacity of the outdoor unit; 400 cfm per ton of capacity (more on this later in the Startup section). The continuous fan speed is selected based on homeowner preference; this is generally one of the lower blower speeds.

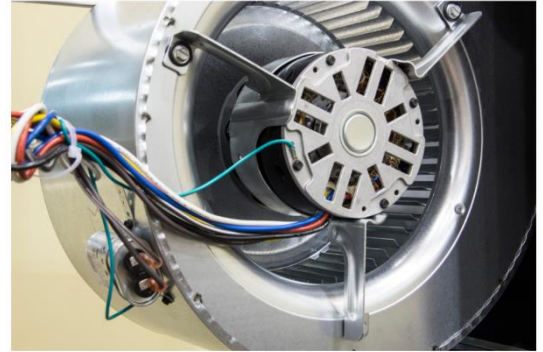

PSC Blower Motor

### Note

The airflow designator in the equipment model number indicates the design airflow delivery at .5" w.c. total external static pressure with the 'high' blower speed selected. All Unitary Products residential furnaces, as most all competitive equipment, are designed to deliver rated airflow at .5" w.c. external static pressure. External static pressure in excess of .5" w.c. will reduce the maximum potential airflow output of the furnace.

## Blower Motor (Standard ECM)

Standard ECM motors offer enhanced electrical performance, quiet ramping, and improved performance across a larger range of external static pressure. All motors have static limitations and must operate within allowable ranges stated on the equipment rating plate.

The Standard ECM motor is programmed to provide constant torque. If the static pressure changes, the motor will only maintain the factory programmed torque. This should not be confused with constant airflow. Even though the Standard ECM can maintain torque, if static pressure increases, airflow will decrease. However, airflow will not decrease as dramatically as with a PSC motor since torque is being maintained.

The applied line voltage is measured between the "L" and "N" terminals on the motor terminal block. This is a 120-volt AC connection.

The control terminals are labeled "C", "1", "2", "3", "4" and "5". Terminal "C" is common for the 24-volt AC control voltage, while terminals labeled "1" through "5" are the preprogrammed torque settings, energized through the "HEAT", "HI COOL", "LO COOL", and "G" blower motor connections on the furnace control board based on the system mode.

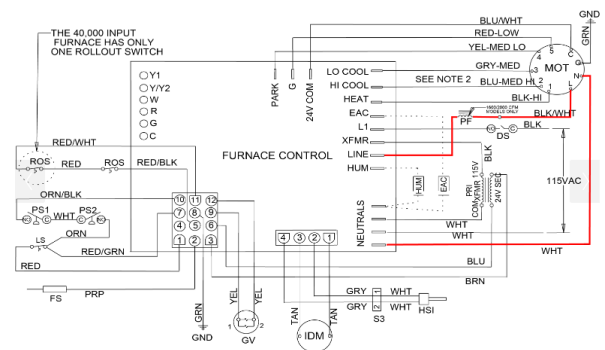



## Blower Assembly Removal

The entire blower assembly slides out on rails for simplified service. To slide the blower assembly out, the ¼" hex head retaining screws, one on the left and one on the right, must be removed. Pull the blower assembly straight out. Enough wiring is provided that disconnection from the furnace control board is not necessary for most service procedures.



Blower Assembly Removal

The blower motors used on the 33" gas furnaces are permanently lubricated and require no oil during routine furnace maintenance.

## Primary Limit

The primary limit switch is mounted on the left side of the furnace vestibule panel. This auto-reset limit switch will open and interrupt the heating cycle if it detects excessive air temperature in the furnace. Primary limit trips are caused by the following conditions.

- Dirty filter
- Dirty evaporator coil
- Dirty secondary heat exchanger
- Debris deflecting air flow away from the switch
- Failure of the circulating blower motor or wheel
- Too many supply or return registers closed or blocked (high external static pressure)
- Excessive manifold gas pressure



### Primary Limit and Primary Limit Circuit

If the primary limit switch trips, the cause must be determined and corrected. In the event the limit switch is replaced, be sure to use the exact Source 1 part number (and limit settings) as specified.

### Rollout Limit

Rollout limits are mounted near the burner assembly. If the temperature in the burner area exceeds a rollout switch set point, the ignition control and the gas valve are de-energized.

#### Important

If the rollout limit opens, the cause must be determined and corrected.

Rollout limits opening may indicate a problem with the gas setup (manifold pressure), a problem with the induced draft assembly, heat exchanger, or venting system.

Because a rollout limit opening can indicate a potentially serious condition, the rollout limits are manually reset.

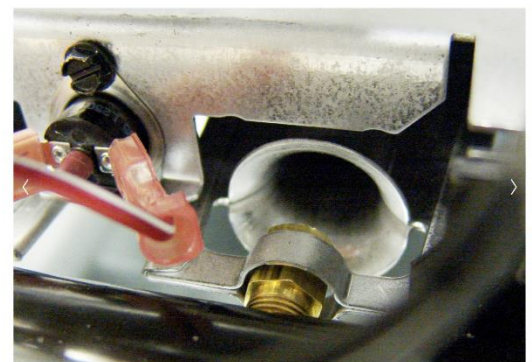

## Inducer

---

The inducer (also referred to as an induced draft blower, combustion blower, or vent blower) provides two functions. It brings air for combustion into the burner box and moves the products of combustion through the heat exchangers, expelling them outdoors.

### Inducer Detail

For installation flexibility, the inducer on the 33" gas furnaces may be rotated 90 degree clockwise (CW) or counterclockwise (CCW). For upflow applications, the exhaust may exit through the top or either side of the cabinet. Downflow applications require that the inducer is rotated so that the exhaust exits through the left or right side of the cabinet.

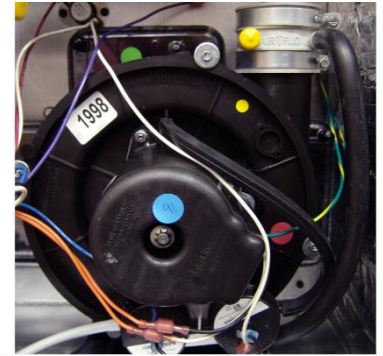

ON a call for heat, after the furnace control board performs internal and system diagnostics (including checking that the pressure switch(es) are open), the first step in the sequence of operation is to energize the inducer. The inducer motor is energized through pins 1 and 3 of the four-pin plug connector on the furnace control board.

## Pressure Switch: Combustion Air

The 33" gas furnaces are equipped with a combustion air pressure switch mounted on the front of the inducer assembly. This switch monitors the flow through the combustion air/vent system. The switch will close at the beginning of each cycle when adequate combustion airflow is established. The "make" (closing) point of the switch is printed on the label on the face of the switch. The switch is diagnosed using a Magnehelic gauge, incline, or U-tube manometer.

Details on diagnosing pressure switch operation can be found in the Troubleshooting section of this Guide.

Never attempt to jump a pressure switch to allow the furnace to operate. Doing so could allow the furnace to operate under hazardous conditions leading to bodily injury, property damage, or loss of life.

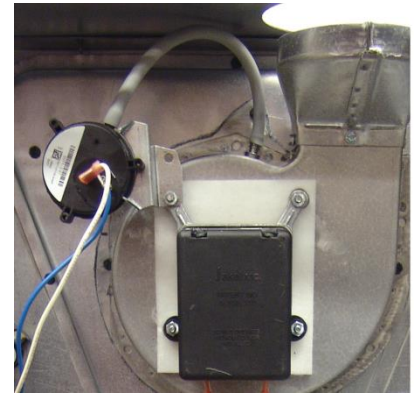

## Pressure Switch: Blocked Drain

The 33" single stage gas furnaces (95% Models) utilize a second pressure switch wired in series with the combustion air pressure switch. If the secondary heat exchanger of the furnace is not draining properly, the blocked drain switch will open, which results in a fault code of 3 on the furnace control board.



The blocked drain pressure switch is diagnosed with a Magnehelic gauge or an incline manometer. An improperly configured or restricted drain system may cause this switch to open, as well as improper field leveling of the furnace. Check all field connections and condensate tubing, and make sure the furnace is installed level or at a very slight pitch towards the front of the furnace.

## Transformer

The transformer steps down the supplied 115 volts AC line voltage to the 24 volts AC control voltage used to supply power to the ignition control, gas valve, thermostat, and other controls. Line power is connected to the line (or primary) side of the transformer, 24-volt power is supplied out of the load, or secondary, side of the transformer.

The "VA" rating of the transformer indicates the maximum voltage (V) times amperage (A) of the components it is supplying power to. For example, the 40 VA transformer rating (as provided on the 33" gas furnaces), indicates that the output voltage (24 volts AC) multiplied by the amp draw of the components it is providing power to cannot exceed 40. 24 volts multiplied by 1.667 amps equals 40, so the maximum amp draw of all components on the 24-volt side cannot exceed 1.667 amps.

A 2-amp automotive-type fuse on the furnace control board helps to protect the transformer from damage due to severe over-current conditions on the secondary (24 volt) circuit.

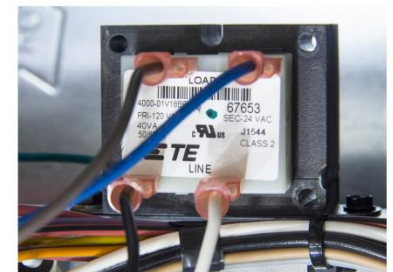

## Blower Door Switch

The 33" furnaces have an electrical interlock switch mounted in the blower compartment that interrupts all power to the furnace when the blower compartment door is removed.

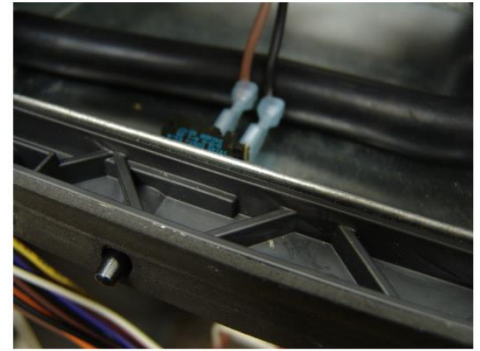

Blower Door Switch

## Raingutter (95% Models)

The raingutter is located at the outlet side of the induced draft blower. It captures condensate from the exhaust piping and drains it away before it reaches the induced draft blower.



Raingutter

## Collector Box (95% Models)

The collector box is mounted to the outlet of the secondary heat exchanger. The unique design allows secondary heat exchanger condensate drainage in four installation positions without an external drain trap.

Installation in the horizontal left, horizontal right, or downflow configuration requires field modification of the condensate drain connection points. Detail is provided in the Installation Section of this Guide and also in the Installation Manual provided with the product and in the Product Center on HVAC Navigator.

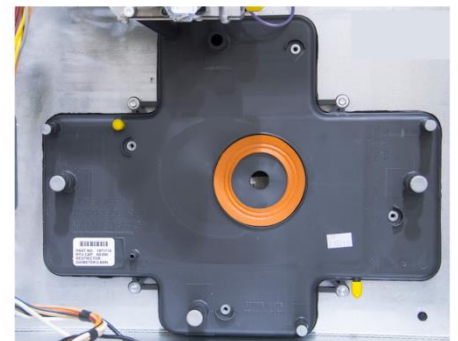

Collector Box

## Condensate Tubing (95% Models)

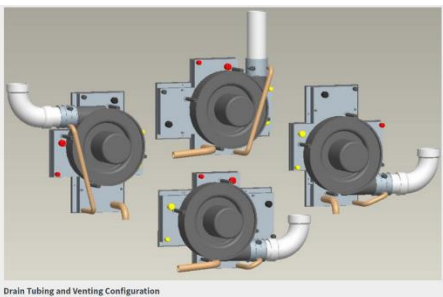

Drain Tubing and Venting Configuration

The collector box contains many connection points for condensate drainage. The connection points used are determined by the chosen furnace position.

Regardless of the furnace configuration or inducer position, the raingutter connection is connected from the raingutter to the tap at the BOTTOM of the collector box for the position the furnace is installed in. When reconfiguring the factory connected drain system, remove the black cap from the desired collector box tap and place on the unused tap.

## Furnace Control Board (PSC 80% and 95% Models)

The integrated furnace control board controls all furnace functions, including component cycling, safety limit monitoring, flame sensing, blower delays, system mode and fault code displays.

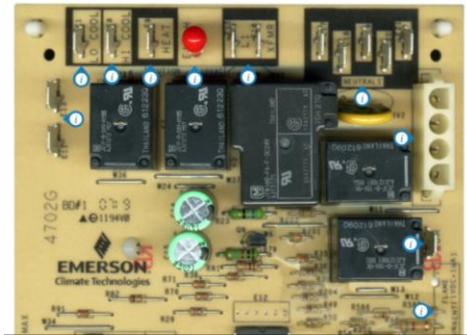

## Single Stage Gas Furnace Control Board (PSC Blower Model)

The ECM blower motor models use 2-volt AC outputs to the Standard ECM blower speed traps. The differences in the ECM board are illustrated below.

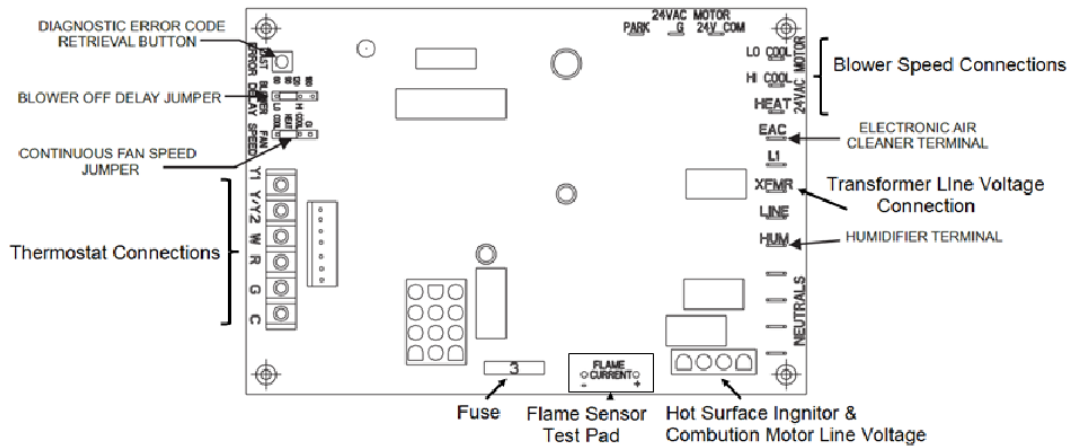

04

---

# Installation

## Installation

---

Taking the time to properly install and start up the 33" single stage gas furnace ensures that the equipment operates at peak efficiency and provides the end user with the comfort and performance they expect from the installation.

This section DOES NOT REPLACE THE INSTALLATION MANUAL of the furnace model you are working with. The Field Reference Guide is designed to be a companion to the model specific Installation Manual.

Be sure to thoroughly read the instructions provided with the furnace.

For specific start up details, see Stage 5, Start Up.

### **Do NOT Use for Temporary Heat**

Materials used in the construction process, when brought into the furnace, greatly reduce furnace efficiency and operational life. Drywall dust, varnishes, paints and sawdust rob the end user of the investment they have made in their comfort system. Use a different source of temporary heat for construction, such as a stand-alone furnace used only for this purpose.



## Inspection

---

When a furnace is received, it should be inspected for possible damage during transit. If damage is evident, the extent of the damage should be noted on the carrier's freight bill. Also, before installation, the unit should be checked for screws, bolts or wiring connections which may have loosened in transit. There are no shipping or spacer brackets requiring removal.

# Furnace Locations and Clearances

The furnace shall be located using the following guidelines:

1. Where a minimum amount of air intake/vent piping and elbows will be required.
2. As centralized with the air distribution system as possible.
3. Where adequate combustion air will be available (particularly when the appliance is not using outdoor combustion air).
4. Where it will not interfere with proper air circulation in the confined space.
5. Where the outdoor combustion air/vent terminal will not be blocked or restricted.
6. Where the unit will be installed in a level position with no more than ¼" (6.4mm) slope side-to-side and front-to-back to provide proper condensate drainage.

## Installation in Freezing Temperatures

1. Temperatures in the furnace location (95% AFUE) **must not** fall below 32°F (0°C) unless the condensate system is protected from freezing.
2. The return air temperature must not drop below 55° F (13° C) for extended periods. Low return air temps may cause condensation in the primary heat exchanger, leading to premature heat exchanger failure.

## Recommended Minimum Clearances

Ample clearances should be provided to permit easy access to the unit.

The following minimum clearances are recommended:

1. Twenty-four (24) inches (61 cm) between the front of the furnace and an adjacent wall or another appliance, when access is required for servicing and cleaning.
2. Eighteen (18) inches (46 cm) at the side where access is required for passage to the front when servicing or for inspection or replacement of flue/vent connections. In all cases, accessibility clearances shall take precedence over clearances for combustible materials where accessibility clearances are greater.

## Vent Clearances

Always consult the Installation Manual for model-specific vent clearances. The image and table below are presented as reference.

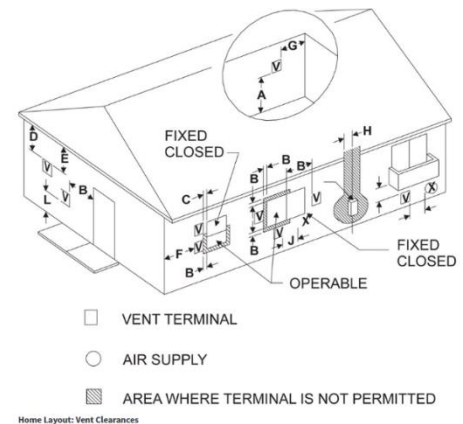

<b>Direct Vent Terminal Clearances</b>	<b>Canadian Installation</b>	<b>US Installation</b>
A. Clearance above grade, veranda, porch, deck, or balcony	12" (30.5 cm)	12" (30.5 cm)
B. Clearance to window or door that may be opened.	12" (30.5 cm) for models less than or equal to 100,000 BTUH (30 kW), 36" (91.4 cm) for models >100,000 BTUH (30 kW).	Two-pipe (direct vent) applications: 12" (30.5 cm) †† Single-pipe applications: 4 feet (1.2 m).
C. Clearance to permanently closed window	12" (30.5 cm)	12" (30.5 cm)
D. Vertical clearance to ventilated soffit located above the terminal within a horizontal distance of 2 feet (61 cm) from the center line of the terminal	12" (30.5 cm) or in accordance with local installation codes and the requirements of the gas supplier.	12" (30.5 cm) or in accordance with local installation codes and the requirements of the gas supplier.
E. Clearance to unventilated soffit	12" (30.5 cm) or in accordance with local installation codes and the requirements of the gas supplier.	12" (30.5 cm) or in accordance with local installation codes and the requirements of the gas supplier.
F. Clearance to outside corner	12" (30.5 cm) or in accordance with local installation codes and the requirements of the gas supplier.	12" (30.5 cm) or in accordance with local installation codes and the requirements of the gas supplier.
G. Clearance to inside corner	3 feet (91.4 cm)	3 feet (91.4 cm)
H. Clearance to each side of center line extended above meter/regulator assembly	Above a meter/regulator assembly within 3 feet (91.4 cm) horizontally of the vertical centerline of the regulator vent outlet to a maximum vertical distance of 15 feet (4.5 m) above the meter/regulator assembly.	Above a meter/regulator assembly within 3 feet (91.4 cm) horizontally of the vertical centerline of the regulator vent outlet to a maximum vertical distance of 15 feet (4.5 m) above the meter/regulator assembly.
I. Clearance to service regulator vent outlet	3 feet (91.4 cm)	3 feet (91.4 cm) or in accordance with local installation codes and the requirements of the gas supplier.
J. Clearance to non-mechanical air supply inlet to building or the combustion air inlet to any other appliance	12" (30.5 cm) for models less than or equal to 100,000 BTUH (30 kW), 36" (91 cm) for models >100,000 BTUH (30 kW).	Two-pipe (direct vent) applications: 12" (30.5 cm) Single-pipe applications: 4 feet (1.2 m).
K. Clearance to a mechanical supply inlet	6 feet (1.83 m)	3 feet (91.4 cm) above if within 10 feet (3 m) horizontally.
L. Clearance above paved sidewalk or paved driveway located on public property.	7 feet (2.13 m) †	7 feet (2.13 m) or in accordance with local installation codes and the requirements of the gas supplier.
M. Clearance under veranda, porch, deck, or balcony	12" (30.5 cm) ‡	12" (30.5 cm) or in accordance with local installation codes and the requirements of the gas supplier.

1. In accordance with the current CSA B149.1-00, Natural Gas and Propane Installation Code.
2. In accordance with the current ANSI Z223.1 / NFPA 54, National Gas Code.
3. In accordance with the current ANSI Z21.47 \* CSA 2.3 American National Standard.

† A vent shall not terminate directly above a sidewalk or paved driveway that is located between two single family dwellings and serves both dwellings.

†† 12" (30.5 cm) up from the bottom edge of the structure for Two-pipe (direct vent) applications per ANSI Z223.1 / NFPA 54, National Gas Code.

‡ Permitted only if veranda, porch, deck, or balcony is fully open on a minimum of two sides beneath the floor and the distance between the top of the vent termination and the underside of the veranda, porch, or deck is greater than 12" (30.5 cm) as specified in CSA B149.1-00.

- A vent shall not terminate less than 12" (30.5 cm) above a grade level.
- Any fresh air or make up inlet for dryer or furnace area is considered to be forced air inlet.
- Avoid areas where condensate drippage may cause problems such as above planters, patios, or adjacent to windows where steam may cause fogging.
- The terminus of a vent shall be fitted with a cap in accordance with the vent manufacturer's installation instructions, or in accordance with the installation instructions for a special venting system.
- Responsibility for the provision of proper adequate venting and air supply for application shall rest with the installer.
- Vent shall extend high enough above building, or a neighboring obstruction, so that wind from any direction will not create a positive pressure in the vicinity of the vent.

## Vent System: 95% Models

---

The 95% AFUE 33" gas furnaces are Category IV, dual certified appliances and are designed for residential application. The combustion air and vent system must be installed in accordance with Section 5.3, Air for Combustion and Ventilation, of the National Fuel Gas Code Z223.1/NFPA 54 (latest edition), or Sections 7.2, 7.3, or 7.4 of CBA B149.1, National Gas and Propane Codes (latest edition) or applicable provisions of the local building code and the furnace Installation Manual.

The 95% AFUE 33" gas furnaces may not be common vented with any other appliance, and require separate, properly sized combustion air intake and exhaust (vent) piping. Refer to the furnace Installation Manual for specific detail on venting specific furnace models.

## Vent System: 80% Models

---

The venting system for the 80% AFUE single stage gas furnaces use type “B” vent pipe, or an approved type “B” connector to a lined masonry chimney of the correct size.

The 80% AFUE model may only be vented to a lined masonry chimney if a source of dilution air is provided, such as common venting with a draft hood equipped water heater. If no source of dilution air is available, a masonry chimney vent kit must be used. Refer to the kit instructions for application and installation requirements.

The 80% AFUE single stage gas furnaces are approved for horizontal, sidewall termination with an approved auxiliary power venter. Consult the furnace Installation Manual for application information.

The vent system must be installed in accordance with Section 5.3, Air for Combustion and Ventilation, of the National Fuel Gas Code Z223.1/NFPA 54 (latest edition), or Sections 7.2, 7.3, or 7.4 of CBA B149.1, National Gas and Propane Codes (latest edition) or applicable provisions of the local building code and the furnace Installation Manual.

## Combustion Air Quality

---

The 95% AFUE 33" gas furnaces are dual certified, meaning that combustion air may be taken from either outdoors (preferably) or inside the structure. The 80% AFUE model draws combustion air from the area surrounding the furnace. Combustion air requirements are determined by the following standards:

- US: Section 5.3 of the **NFGC**, Air for Combustion and Ventilation
- CANADA: Part 7 of **NSCNGPIC**, Venting Systems and Air Supply for Appliances

If considering taking combustion air from within the structure, there are many factors to consider. **OUTDOOR AIR** for combustion is required when the furnaces are located in any of the following environments:

- Commercial buildings
- Buildings with indoor pools
- Laundry rooms
- Hobby or craft rooms
- Chemical storage areas

The furnace requires **OUTDOOR AIR** for combustion when the furnace is in an area where the furnace is being exposed to the following substances and / or chemicals:

- Permanent wave solutions
- Chlorinated waxes and cleaners
- Chlorine based swimming pool chemicals
- Water softening chemicals
- De-icing salts or chemicals
- Carbon tetrachloride
- Halogen type refrigerants
- Cleaning solvents
- Printing inks, paint removers, varnishes, etc.
- Hydrochloric acid
- Cements and glues
- Antistatic fabric softeners for clothes dryers
- Masonry acid washing materials

## Ductwork Installation

---

To properly design the ductwork for the building, refer to the ASHRAE Fundamentals Handbook chapter on “DUCT DESIGN”, or ACCA Manual ‘D’.

It is imperative that the duct system is designed properly per these methods. As with all residential equipment, the 33” single stage gas furnaces are designed to deliver their rated airflow up to 0.5” w.c. total external static pressure. Higher external static values can cause problems with system performance and customer comfort. This may include:

- Temperature rise outside of the allowable range on the furnace rating plate, causing undue stress on the heat exchangers.
- Inadequate cooling performance, including evaporator coil frosting / freezing in the cooling mode, possibly leading to liquid refrigerant getting back to the compressor and eventual compressor failure.
- Inadequate airflow to the conditioned space.
- Customer complaints about noisy operation. If whistling is heard in and around the furnace area during blower operation, it is likely that there is an airflow problem.

For more information on determining where problems are in the air distribution, see Section 5, **Start Up**. Included is a discussion on measuring external static pressure (“ESP”) in the duct system.



## Furnace Configuration and Conversion

---

The 33" single stage gas furnaces are multiposition, meaning that they may be installed in upflow, downflow, horizontal left, and horizontal right applications with little modification. The furnace as shipped from the factory is configured for upflow application. The illustrations shown below, taken from the furnace Installation Manual, indicate inducer and condensate tube locations for various furnace positions.

### Important

Always read and completely understand the Installation Manual provided with the product before installing a gas furnace. If there are questions related to installation or application, please request assistance from your local Unitary Products distributor or branch.

# Condensate Management – 95% Models

The illustrations below illustrate the condensate drain arrangement for the various possible furnace and inducer positions. The furnace condensate pan is self-priming and contains an internal trap to prevent flue gas leakage.

The condensate will flow to the drain more efficiently if an open tee, or short length of pipe is installed in the drain line external to the furnace.

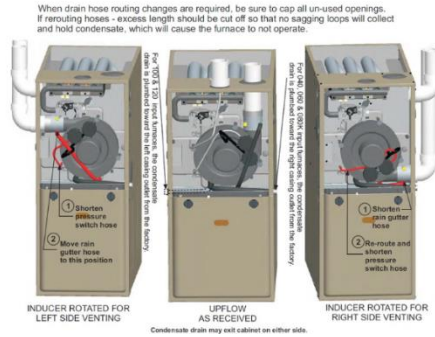
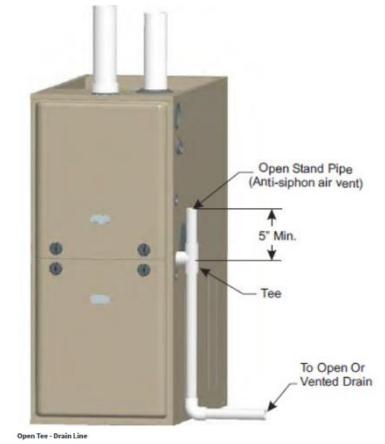

## Upflow Drain Configuration

### Upflow Drain Configuration

When drain hose routing changes are required, be sure to cap all un-used openings. If rerouting hoses - excess length should be cut off so that no sagging loops will collect and hold condensate, which will cause the furnace to not operate.

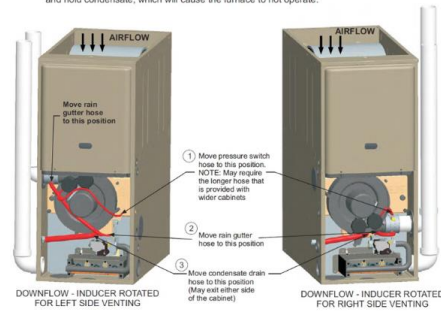

## Downflow Drain Configuration

### Downflow Drain Configuration

When drain hose routing changes are required, be sure to cap all un-used openings. If rerouting hoses - excess length should be cut off so that no sagging loops will collect and hold condensate, which will cause the furnace to not operate.

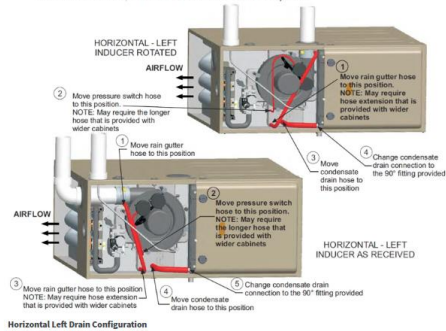

## Evaporator Coil Installation

---

If a matching evaporator coil is used, it may be placed directly on the furnace outlet and sealed to prevent leakage. The evaporator coil must only be installed in the supply air duct, downstream of the furnace.

Follow the coil installation instructions for installing the supply plenum. On all installations without a coil, a removable access panel is recommended in the outlet duct such that smoke or reflected light would be observable inside the casing to indicate the presence of leaks in the heat exchanger. This cover shall be attached in such a manner as to prevent leaks.

## Line (Supply) Voltage

---

Field wiring to the unit must be grounded.

Provide a power supply separate from all other circuits. Install overcurrent protection and disconnect switch per local/national electrical codes. The switch should be close to the unit for convenience in servicing. With the disconnect or fused switch in the OFF position, check all wiring against the unit wiring label.

Remove the screws retaining the junction box cover. Route the power wiring through the opening in the unit into the junction box with a conduit connector or other proper connection. In the junction box there are three wires, black, white, and green.

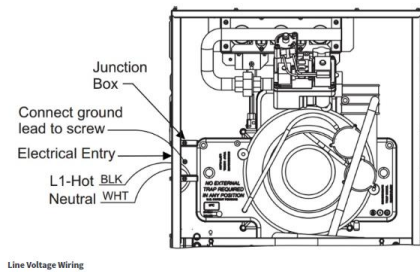

The black furnace lead must be connected to the L1 (hot) wire from the power supply. The white furnace lead must be connected to neutral. Connect the green furnace lead (equipment ground) to the power supply ground. An alternate wiring method is to use an approved field provided 2" (5.08 cm) x 4" (10.2 cm) box and cover on the outside of the furnace. Route the furnace leads into the box using a protective bushing where the wires pass through the furnace panel. After making the wiring connections replace the wiring box cover and screws.

The furnace control system requires correct polarity of the power supply and a proper ground connection. The furnace will not operate until the polarity is correct. To verify, measure voltage between L1 and neutral, then compare the reading with L1 and ground. These readings should be within three volts of each other. A reading taken between neutral, and ground should read zero volts.

## Control Wiring

---

Install the field-supplied thermostat by following the instructions that come with the thermostat. Use of a quality thermostat is recommended for best performance and occupant comfort. Triac-switching and power stealing thermostats should be avoided since these thermostats may have compatibility issues.

With the thermostat set in the OFF position and the main electrical source disconnected, connect the thermostat wiring from the wiring connections on the thermostat to the terminal strip on the furnace control board.

Apply strain relief to thermostat wires passing through cabinet. If air conditioning equipment is installed, use thermostat wiring to connect the Y and C terminals on the furnace control board to the outdoor unit.

The 24-volt, 40 VA transformer is sized for the furnace components only, and should not be connected to power auxiliary devices such as humidifiers, air cleaners, etc. The transformer may provide power for an air conditioning unit contactor.

For additional connection diagrams for all Unitary Products equipment refer to “Line Voltage System Wiring” document available online at [www.solutionnavigator.com](http://www.solutionnavigator.com) in the Product Catalog Section.

## Electronic Air Cleaner (EAC)

---

A 1/4" spade terminal labeled "EAC" is provided for electronic air cleaner connection on the control board. This terminal provides 120 volts AC (1.0 amp maximum) during circulating blower operation. 120 volts AC neutral for the EAC is provided on the "NEUTRALS" 1/4" terminals on the control board.

## Humidifier (HUM)

---

A 1/4" spade terminal labeled HUM is provided for humidifier connection on the control board. This terminal provides 120 volts AC (1.0 amp maximum) during heating system operation after the gas valve is energized and flame has been sensed. 120 volts AC neutral for the humidifier is provided on the "NEUTRALS" 1/4" terminals on the control board.

## Twining

Twining is used to allow two identical furnaces (with identical control boards) to operate in tandem using one duct system.

Twining is not allowed on modulating or variable speed furnaces - single stage only. Twinned furnaces have an approximate 15% reduction in additive airflow. In these applications, extra care must be taken in the design of the duct system. Additionally, both of the twinned furnaces must be energized from the same leg (or phase) of the building's electrical supply to avoid twining error faults in the communication from board to board.

When two furnaces are installed using the same duct system, it is very important that the two furnace circulating air blowers operate in unison. If one blower starts before the second blower, the duct system will become pressurized and the blower on the second furnace will turn backwards causing the second furnace to overheat. The TWIN terminal provides synchronization of the furnace blowers to prevent this from happening.

A single wire is connected between the TWIN terminal on one furnace board to the TWIN terminal on the second furnace board. The board communicates the blower status from one furnace to the other along this wire. This communication makes the second furnace blower come on at the same time, and on the same speed, as the first furnace blower.

### Single-Wire Twining Installation

Connect the control wiring as shown in the "Single Stage Twining Wiring Diagram" shown in Figure 3-6.

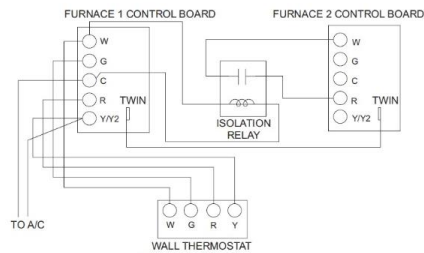

### Twining as Single Stage

1. Connect the low voltage wiring from the wall thermostat to the terminal strip on the control board of Furnace #1.
2. Connect a wire from the TWIN terminal of Furnace #1 to the TWIN terminal of Furnace #2.
3. Install a separate 24V relay as shown in the diagram. Use of this relay is required - it isolates the transformers of the two furnaces, preventing the possibility of any safety devices being bypassed.

**Heating** - On a call for heat (W signal) from the wall thermostat, both furnaces will start the ignition sequence and the burners on both furnaces will light. About thirty seconds after the burners light, the blowers on both furnaces will come on in heating speed. When the thermostat is satisfied, the burners will all shut off and, after the selected blower off delay time, both blowers will shut off at the same time. The twining control ensures that both blowers come on and shut off at the same time.

**Cooling** - On a call for cooling (Y signal) from the wall thermostat, both furnace blowers will come on at the same time in cooling speed. When the thermostat is satisfied, both blowers will stay on for 60 seconds, then will shut off at the same time.



Continuous Fan - On a thermostat call for continuous fan (G signal), both furnace blowers will come on at the same time in cooling speed and will stay on until the G signal is removed.

## Two Stage Twinning

This control can also be used along with a two-stage heat wall thermostat to stage two twinned furnaces, making them operate as a two-stage furnace. This allows one furnace to supply heat during times when the heat output from one furnace is sufficient to satisfy the demand.

## Twining as Two Stage

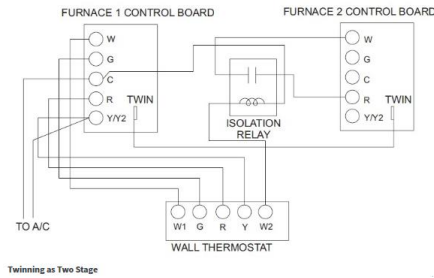

05

---

# Start-up

## Ducted Systems Products Residential Start-up Form

---

The online form is for use with all Ducted Systems residential products. The form allows saving for later completion. Completed form data is sent to your inbox for archive purposes.

### Before Continuing

Prior to start-up, all the installation procedures outlined in the furnace Installation manual must be completed. This includes gas piping, electrical wiring, duct connections, and condensate drain connection.

## Required Tools and Information

Contact the local gas supplier to obtain the heating value of the natural gas. This information will be needed in calculating the input to the furnace. If the heating value varies greatly from 1030 btu/cu ft, an orifice change may be required to make sure that the furnace has 100% of its nameplate input rating available to it. See the section in the Installation Manual entitled “Calculating Furnace Input”.

The following instruments are required to properly set up the 33” single stage gas furnace:

- Thermometer or portable digital thermometer to verify the supply and return air temperatures. For best accuracy, use thermocouple-type thermometers and probes.
- U-tube manometer or digital manometer that has the ability to read pressures between 0-15” w.c. (0-3.73 kPa) to measure the gas line and the manifold pressures.
- Allen wrench (3/32”) for manifold pressure adjustment
- Digital multimeter
- Philips head screwdriver
- ¼” nutdriver (all hex head screws on the 33” furnace is ¼”, except for the blower motor bracket screws)

## Gas Pipe Leak Check and Bleed

### Repair any gas leaks prior to continuing the start-up process

With the furnace in operation, check all of the pipe joints, gas valve connections and manual valve connections for leakage using an approved gas detector, a non-corrosive leak detection fluid or other leak detection methods. Take appropriate action to stop any leak. IF a leak persists, replace the faulty component. The furnace must be isolated from the gas supply piping system by closing the equipment shutoff valve during any pressure testing of the gas supply system.

Burner ignition may not be satisfactory on first startup due to residual air in the gas line or until gas manifold pressure is adjusted. The ignition control will make three attempts to light before locking out.

To bleed air from the gas line, it is recommended that when the gas supply is first connected to the furnace, the ground union is loosened until the odor of gas is detected. When gas is detected, immediately tighten the union, and check for gas leaks. Allow five minutes for any gas to dissipate before continuing with the startup procedure. BE sure that proper ventilation is available to dilute and carry away any vented gas.

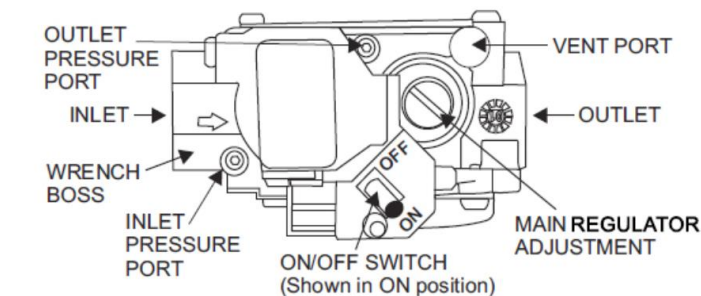

Gas Valve

## Line Pressure Measurement

Line pressure is measured on the inlet side of the gas valve. Line pressure to the valve should not exceed the values on the furnace rating plate. The minimum and maximum supply pressures are listed on the furnace's rating plate.

To attain the full nameplate input of the furnace, the inlet pressures should be between 4.5" – 7" w.c. for natural gas applications, 11" – 14" w.c. for LP. The minimum inlet pressure should be checked with all gas appliances on the building operating at full capacity.

## Inlet Gas Pressure

Prior to measuring the gas line pressure, ensure that the furnace is properly equipped to utilize the gas type being supplied. Refer to the furnace's rating plate for this information. The 33" gas furnaces require a gas conversion kit for use with propane (LP) gas. Turn off the manual shut off valve in the gas line. Loosen the 3/32" allen plug ONE FULL TURN, but do not remove.

Place the manometer tube (or boot) over the inlet pressure fitting. Slowly open the manual gas shut off valve and observe the line pressure. Turn off all other gas appliances in the structure if accessible to ensure that line pressure does not drop with the other appliances in operation. If it drops significantly with the other appliances in operation, a problem with the gas supply and/or pipe sizing may be indicated and must be corrected.

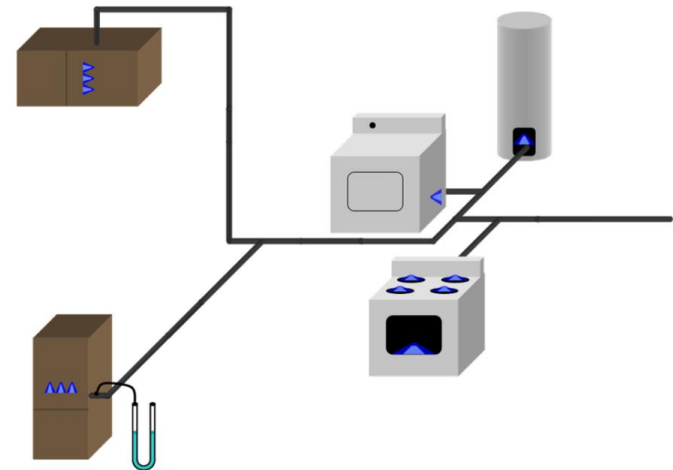

Measure Inlet Pressure with All Other Gas Appliances Operating

After the line pressure has been verified and is adequate, the proper gas manifold pressure must be established.

## Nominal Manifold Pressure

The following manifold pressure (gas valve outlet) values are required during furnace operation.

- Natural Gas 3.5" w.c. (.87 kPa)
- Propane (LP) 10.0" w.c. (2.39kPa)

These values may vary slightly depending on the altitude of the area the furnace is installed in and/or the BTU/cubic foot value of the gas used. The exact value for these conditions may be found in the furnace Installation Manual.

The manifold gas pressure must ALWAYS be properly set up during furnace installation and verified during service. All 33" single stage gas furnaces are shipped for use with natural gas. If LP gas use is required, the appropriate LP gas conversion kit must be installed prior to furnace operation.

To measure manifold gas pressure, remove the furnace door covering the vestibule area. Loosen the 3/32" outlet pressure tap allen plug ONE FULL FURN, but do not remove. Place the manometer tube (or boot) over the outlet pressure fitting.



To make adjustments to the manifold pressure, remove the screw cap from the main regulator adjustment, and turn the 3/32" allen adjustment clockwise to increase manifold pressure, counterclockwise to reduce manifold pressure.

After setting the manifold pressure to the recommended setting, be sure to replace the screw cap on the gas valve and tighten the outlet pressure tap fitting.

## Burner Flame Inspection

The flames must be blue in color and extend from the burner directly through the openings in the vestibule panel and into the heat exchanger. A yellow or lazy flame indicates a combustion problem, which must be investigated and corrected.

## Calculating Furnace Input (Clocking the Meter)

Be sure to follow the procedure outlined in the furnace Installation Manual for clocking the gas meter. This will verify that the furnace is firing at 100% of nameplate input.

Burner orifices are sized to provide input rate using natural gas with a heating value of 1030 BTU/Ft<sup>3</sup> (38.4 MJ/m<sup>3</sup>). If the heating value of the gas is significantly different, it may be necessary to replace the orifices.

## Temperature Rise Measurement

Temperature rise is the difference between the temperature of the return air and the heated supply air leaving the furnace. Temperature rise must be measured during installation and must be within the range on the furnace rating plate. This is important not only for the longevity of the furnace but also for customer comfort.

The furnace should be operating in the heating mode for approximately 20 minutes prior to taking temperature measurements. Taking readings of both the return air and the heated air in the ducts, about six feet (1.83 m) from the furnace where they will not be affected by radiant heat. Subtract the return air temperature from the supply air temperature to determine the temperature rise.

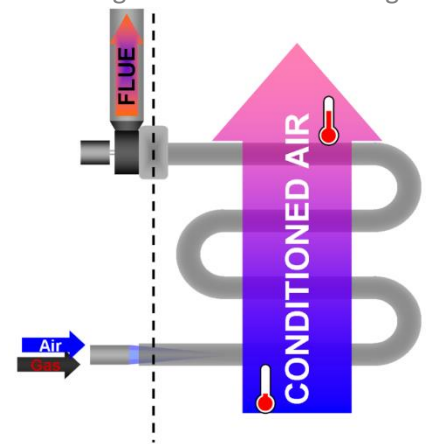

## Temperature Rise Adjustment

The temperature rise must be within the range shown on the furnace rating plate and within the application limitations shown on the furnace rating plate.

The blower motor speed is increased to reduce the temperature rise, and the blower speed is reduced to increase the temperature rise.

The blower motor speed taps are located at the furnace control board. Refer to the unit-wiring label to change the blower speed. Blower motor speeds commonly follow these color codes.

To use the same speed tap for heating and cooling, the “HEAT” terminal and “COOL” terminal must be connected using a jumper wire and connected to the desired motor lead. Place all unused motor leads on Park terminals.

If the temperature rise cannot be brought within the range allowed on the furnace rating plate, make sure that there are no problems in the duct system (i.e., high external static pressure) restricting proper airflow through the system.

To check for airflow problems:

- Verify that filters are clean, and all registers and heat runs are open
- Check duct system for excessive restriction with the use of Magnehelic gauge or incline manometer

## Standard ECM and PSC Indoor Fan Motors

Speed tap adjustments are made at the terminal block for PSC or Standard ECM motors. Use the blower performance data in the Installation Manual or Tech Guide to set-up proper air flow.

To achieve the desired indoor airflow, connect the motor wires to the corresponding motor speed tap receptacle on the motor housing. Motor wiring details are located on the unit wiring label.

## Cooling Blower Speed

It is often believed that the cooling blower speed should always be positioned at the highest setting. This is not true for every application. If the airflow is set too high for the application, proper dehumidification of the return air won't occur, and the desired temperature drop across the evaporator coil will not be obtained. If the airflow is set too low, frost and ice may form on the evaporator coil, which will lead to eventual refrigerant flood back to the compressor. For the best possible comfort and equipment longevity, the ESP should be measured and used with the blower charts provided to determine the best speed to use for the application.

## Cooling CFM

For optimum performance, 400 CFM per ton of air conditioning is generally used. For instance, a 3-ton system should have 1200 CFM of air moving through the evaporator coil.

To determine the total external static pressure, both the supply and return static pressures must be measured.

To measure the supply static pressure, connect the Magnehelic gauge probe to the port marked high. The probe should be inserted immediately off the supply duct connection, under the evaporator coil if possible. This will allow the measurement of the supply static pressure and resistance to airflow imposed by the evaporator coil, supply duct, fittings, and registers. A common supply value for a properly designed supply duct system with a clean, dry evaporator coil is .3" to .35" w.c.

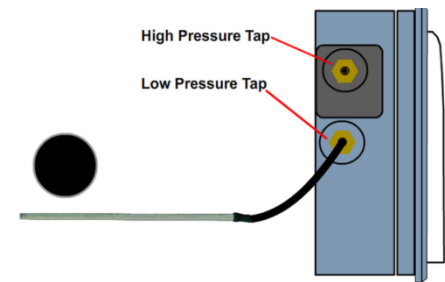

Magnehelic® Connections

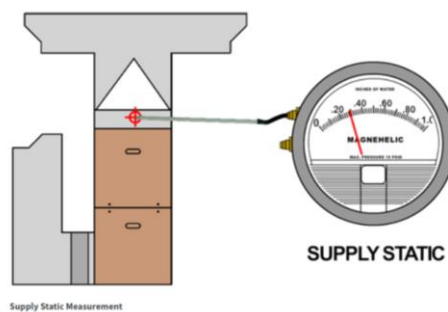

To measure the return static pressure, connect the Magnehelic probe to the port marked "low". The probe should be inserted between the filter and the furnace. This will allow the measurement of the return static pressure and resistance to airflow imposed by the filter, return drop, return ductwork, fittings and grilles. If access cannot be obtained between the furnace and the filter, another location to measure return static is through a grommet on the side of the blower section.

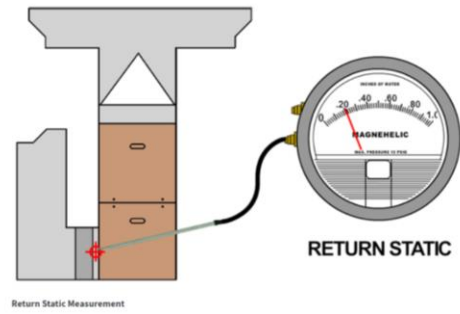

The total external static pressure can be determined either by taking the supply and return static pressures individually and adding them, or simply by using two probes and noting the reading on the gauge.

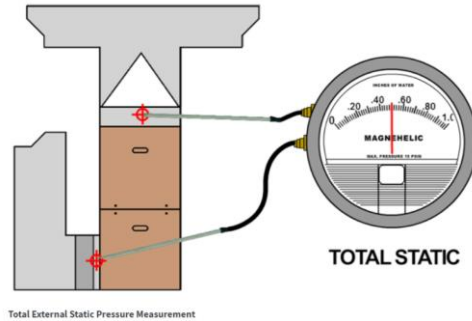

After the total external static pressure has been determined, apply the total static pressure to the blower performance chart for the furnace or air handler model being serviced. The CFM being delivered is where the ESP reading intersects with the blower speed being used. Remember that 400 CFM per ton is the target value. If required, change the blower speed to get as close as possible to 400 CFM per ton.

The blower performance charts provided with the 33" single stage gas furnaces indicate blower performance without filters in place. To determine the CFM performance at the blower speed being used, take the external static measurements without the filter(s) in place. Then follow the procedure outlined in the installation manual to adjust for the pressure drop (loss of CFM) through the filter type used.

After a blower speed change, recheck the total ESP and consult the blower performance chart to verify CFM.

If working with a furnace and the blower charts are not available, use the following procedure to determine an approximate CFM.

- Verify that the furnace is firing at 100% of its nameplate input
- Set the blower speed to the speed tap intended for use for cooling
- After 15 minutes of furnace operation, measure the temperature rise across the furnace
- Put the temperature rise into this formula:  $\text{BTU Output} / 1.085 \times \text{Temp Rise}$
- 400 CFM/Ton is the desired target value

For example, an 80,000 BTUH furnace that has an AFUE of 90 provides 72,000 BTUH net output. 72,000 divided by  $(1.085 \times \text{the temp rise } (50))$ . 72,000 divided by 54.25 is 1327.19 CFM. At 400 CFM per ton, this would be more than adequate airflow for a three-ton system, which requires 400 CFM. Adjust the blower speed as required to attain approximately 400 CFM per ton.

## Continuous Fan Operation

The airflow delivered by the furnace during continuous fan operation ("Fan On") is the selected heating speed on control boards without a "Cont Fan" blower speed connection. Control boards with a "Cont Fan" terminal will energize the blower speed that is connected to it with a "Fan On" call.



06

---

# Sequence of Operation

## Introduction

---

### Important

A complete understanding of the sequence of operation of the product being serviced is imperative to success as a service technician.

This section provides insight on the heating mode, cooling mode, and continuous fan sequence of operation of the 33" single stage gas furnace.

## Heating Mode

---

Most of today's induced draft gas furnaces, no matter the ignition system type, use a similar sequence of operation for heating mode. The 33" single stage gas furnaces are no different. The basic sequence of operation is as follows:

1. A call for heat occurs when the thermostat closes the R-W circuit.
2. The induced draft blower starts.
3. The operation of the induced draft blower is proven with a pressure switch.
4. The ignition sequence begins.
5. Flame is established and proven.
6. The main blower is energized.

Following is detailed information on each step of the sequence.

### Call for Heat

The "R" terminal on the furnace control board provides 24-volt power to the thermostat. On a call for heat, the 24-volt power from the "R" circuit is allowed to pass through the thermostat on the "W" circuit, initiating the furnace heating cycle. 24 volts AC measured between "W" and "C" on the furnace terminal strip indicates that a call for heat is present.

The control verifies that the pressure switch is open prior to initiating the heating sequence. This check confirms that a jumper wire has not been placed across the pressure switch.

### Induced Draft Blower Starts

The inducer, also referred to as an induced draft blower, combustion blower, or vent blower, provides two functions. It brings air for combustion into the burner area and expels the products of combustion outdoors after they exit the heat exchanger.

The inducer motor is energized with line voltage (120 volts AC), through pins 1 and 3 on the furnace control board four pin plug connector.

The proper operation of the inducer is verified by the next component in the sequence of operation, the pressure switch.

### Pressure Switch Closes

The combustion air pressure switch is present to ensure that the induced draft motor is coming up to speed and that there are no restrictions within the vent system. The combustion air pressure switch is "normally open" ("N/O") and closes after the inducer motor is energized, allowing the ignition sequence to continue.

The 33" single stage gas furnaces utilize a second pressure switch on 95% AFUE models (blocked drain pressure switch) which is wired in series with the combustion air pressure switch. If either one of these switches opens, the furnace control board will display a flash code of 3 red flashes.

Information about the closure or "make" pressure of the pressure switches can be found on the switch labels.

The position of the pressure switch contacts can be verified by taking a voltage reading across the switch. On the 24-volt control systems, 24 volts will be read across an open switch, and will read zero volts if the switch is closed. To test for continuity across the switch with an ohmmeter, the wiring to the switch must first be disconnected. A closed switch will read continuity or zero resistance with an ohmmeter.

If the combustion air pressure switch is not closing with the inducer operating, it must be determined if there is a problem with the switch itself, or if there is another problem causing the switch to not close. The best method of doing this is with the Magnehelic gauge or incline manometer. A scale of 0-5" w.c. will work well for testing pressure switches in most applications.

The Magnehelic gauge or incline manometer should be teed into the pressure switch tubing on both sides using 1/8" tees. Doing so puts the Magnehelic gauge in parallel with the pressure switch, and it will read the same pressure that is being seen at the pressure switch.

Create a call for heat and observe the pressure on the gauge. If the value read on the Magnehelic gauge indicates a negative pressure (less than zero), the hose connections on the Magnehelic gauge are connected incorrectly. Reverse the connections to read the pressure in a positive value.

If the reading on the gauge is in excess of the make point of the switch and the switch is not closing, it is defective and must be replaced.

If the reading on the gauge is a lower value than the make point of the pressure switch, a problem exists that is not allowing sufficient combustion air to flow through the furnace.

A common cause is obstruction in the intake or exhaust piping, which could be any of the following:

- Rocks, balls or other items that may have been placed in the pipe.
- Snow or ice restrictions.
- Rodents, insects or insect nests.
- Improper support of exhaust piping on condensing furnaces, allowing condensate to remain in the piping.
- Undersized piping, too long of a piping run, or too many elbows in the venting system.

The best way to determine if one of these items is a problem is to disconnect the intake and exhaust piping from the furnace. If the reading on the gauge greatly increases with the piping disconnected, the problem lies in the vent system. Reconnect the intake and exhaust after testing.

If the pressure reading on the gauge doesn't increase enough to close the pressure switch even with the vent pipe disconnected, check for the following:

- Pressure switch tubing cracked, kinked, obstructed, or disconnected.
- Inducer wheel loose on the motor shaft.
- Blades missing on the inducer wheel.
- Tight bearings on the inducer motor.
- Restricted pressure tap ports.
- Blocked condensate drains.

The blocked condensate drain pressure switch provides redundant protection in the event the condensate drain system becomes blocked.

Never attempt to adjust a pressure switch or use a different switch than the one specified for the furnace model being serviced. Never attempt to jump the switch to allow the furnace to operate. Doing so could allow the furnace to operate under hazardous conditions leading to bodily injury, property damage, or loss of life.

## **Ignition Sequence Begins**

After the pressure switch proves that the inducer has come up to speed and there are no significant restrictions in the system, the trial for ignition begins. The ignitor is energized with 20 volts AC, measurable between pins 2 and 4 of the furnace control board four pin plug connector. The hot surface ignition system has a 17 second ignitor warm up period before the gas valve is energized.

The gas valve is energized after the ignitor warm up period has expired. The gas valve is energized with 24 volts AC, measurable between pins 9 and 12 pin plug connector.

Once the main gas valve is opened, there is a “window” of a few seconds for the flame to become established and stable. The furnace control then looks for proof that the flame has been established.

## Flame Proof

The flame sensor proves the presence of flame during the trial for ignition. The flame sensor consists of a metal flame rod and a ceramic insulator. The flame sensor must be immersed in the flame to perform its function.

During a call for heat the flame sensor is energized with 120 volts AC from pin 2 of the 12-pin plug connector. In the presence of flame, this AC voltage is rectified through the flame to DC current. This is known as flame rectification. This rectified signal is read in DC microamps (uA).

A flame current pad is built into the furnace control board. This pad allows measurement of the flame current using a DC voltmeter. 1 volt DC = 1 uA (microamp).

Under normal conditions, approximately 3.7 volts DC (3.7 volts DC, which equals 3.7 microamps) should be measured at the flame current pad. The furnace control board requires at least .1 volts DC (.1 microamps) to allow the heating cycle to continue and will indicate a weak flame signal (via amber flash code on the LED) if the flame current drops below 1.5 microamps.

If the flame signal is not adequate for flame proof, check the following:

- A dedicated ground wire must be connected to the furnace.
- All wiring connections must be tight.
- Manifold pressure must be correct per the furnace rating plate.
- The flame must be impinging on the flame sensor.
- The flame sensor must be clean and free of oxidation. If necessary to clean, use steel wool.
- The porcelain on the flame sensor must be intact.

## Blower Energizes

After flame is sensed, the furnace control board begins the main “blower on” delay (30 seconds). This allows the heat exchangers adequate time to warm up, which prevents condensation of flue products on the inside of the primary heat exchanger and provides the customer with comfortable warm air. The 33” single stage gas furnace control boards have a ¼” spade connection marked “HEAT” for connection of the selected heating blower speed tap.

Output to the blower motor can be measured by measuring the AC voltage output between terminals “HEAT” and 120-volt AC common (PSC models) and “HEAT” and 24V COM (Standard ECM models).

## Call for Heat Ends

The thermostat ends the call for heat by breaking the “R” to “W” circuit. 24 volts AC is removed from the “W” terminal on the furnace control board. The gas valve is de-energized immediately, and the furnace control begins the “blower off” delay timing. The inducer is de-energized after a brief “post purge” period. The control confirms that the flame signal is lost immediately after the gas valve is de-energized. This feature is field-adjustable using the blower off delay jumper on the furnace control board. It is advisable to set up the “blower off” delay timing as long as possible (to allow the residual heat to be used to heat the structure), but not so long the discharge air temperature becomes too cold and makes the customer uncomfortable.

The heating cycle is complete, and the system is ready for another call.

## Cooling Mode

---

### First Stage Cooling

“R” to “Y” thermostat contacts close and compressor “Y/Y2” terminal is energized. The outdoor unit contactor coil is energized by its connection to the “Y/Y2” terminal and “C” (24-volt AC common). The blower motor operates at the speed selected on the “HI COOL” control board tap.

### Second Stage Cooling (if equipped)

Two stage cooling requires a 2-stage cooling thermostat. When “R” and “Y1” contact close, the compressor “Y1” terminal is energized, and the blower motor operates at the speed selected on the “LO COOL” control board tap.

When “R” and “Y/Y2” close, the blower motor is energized at the speed selected on the “HI COOL” control board tap. The outdoor unit compressor will be energized at the second stage through the “Y/Y2” terminal.

### Continuous Fan (Recirculation Mode)

When the thermostat fan switch is in the ON mode (R-G), the blower motor operates at a single speed as selected on the “Cont Fan Speed” jumper block (PSC models) or the ‘G’ blower speed tap (Standard ECM models).

07

---

# Troubleshooting

## Introduction

---

All 33" single stage gas furnace control boards have built-in self-diagnostic capability, which is provided through a tri-color LED. The LED flashes red, green, and amber to indicate various conditions.

### Regarding LED Codes

Do not use the LED codes blindly. The LEDs point the technician in the right direction, but a solid foundation of fundamental troubleshooting techniques is critical to effective service.

As an example, a flash code of three red flashes indicates that the normally open pressure switch contact did not close after the inducer was energized. This is not an indication to replace the switch! There is more than likely a reason that the switch has not closed, such as a restriction the vent system, disconnected pressure switch tubing, etc.



## Tri-Color LED

---

The LED is mounted on the furnace control board and is visible through the clear view port in the blower compartment door. If a system problem occurs, a blinking LED shows a RED flash code. GREEN flashes indicate normal standby operation. AMBER flashes are used to indicate system status.

**Red Flash: System Fault**

**Slow Green Flash: Normal Operation**

**Slow Amber Flash: Normal operation with call for heat**

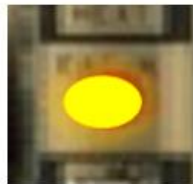

Amber LED

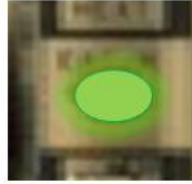

Green LED



Red LED

The control continuously monitors its operation and the operation of the system. If a failure occurs, the LED will indicate the failure code. If the failure is internal to the control, the light will stay on continuously. Before continuing, power to the control board should be disconnected and re-energized. If the light comes back on continuously, the entire control has failed and should be replaced. The control is not field repairable.

Flash sequence codes 1 through 10 are as follows: LED will turn "ON" for 1/3 second and "OFF" for 1/3 second. This pattern will be repeated the number of times equal to the code. For example, six "on" flashes equals a number 6 fault code. All flash code sequences are broken by the 2 second "OFF" period.

**Slow green flash:** Normal operation, no thermostat calls

**Slow amber flash:** Normal operation with call for heat.

**LED steady off:** If the LED light does not flash at all, check for power to the board and check for a blown fuse on the board. If the board is properly powered and the fuse is not blown, the control board may need to be replaced.

**Steady on any color:** Control failure. Turn the furnace off and back on. If the fault code returns, the control board must be replaced. The control board is not field-repairable

**Rapid Red Flash:** Twinning error, incorrect 24-volt phasing. Check twinning wiring. In newer control boards this is shown to be a 9 Red Flash

**Rapid Amber Flash:** Flame sense current is below 1.5 microamps. Check for proper gas flow. Check and clean flame sensor. Normal flame sense current is approximately 3.7 microamps DC. Low flame signal warning starts at 1.5 microamps. Low flame signal control lockout point is 0.1 microamps.

**4 Amber Flashes:** The control board is receiving a "Y" signal from the thermostat without a "G" signal, indicating improper thermostat wiring.

**1 Red Flash:** This indicates that flame was sensed when there was not a call for heat. With this fault code the control will turn on both the inducer motor and supply air blower. A gas valve that leaks through or is slowly closing would typically cause this fault.

**2 Red Flashes:** This indicates that the normally open pressure switch contacts are stuck in the closed position. The control confirms these contacts are open at the beginning of each heat cycle. This can occur due to a technician-applied jumper wire or, in rare cases, pressure switch contacts that are stuck in the closed position.

**3 Red Flashes:** This indicates the normally open pressure switch contact did not close after the inducer was energized. This could be caused by a number of problems, faulty inducer, blocked vent pipe, broken pressure switch hose or faulty pressure switch.

**4 Red Flashes:** This indicates that a primary or auxiliary limit switch has opened its normally closed contacts. With this fault code, the control will operate the supply air blower and inducer. This condition may be caused by a dirty filter, improperly sized duct system, incorrect blower speed setting, incorrect firing rate or faulty blower motor.

**5 Red Flashes:** This fault is indicated if the normally closed contacts in the rollout switches open. The rollout control is manually reset. If it has opened, check for proper combustion air, proper inducer operation and primary heat exchanger failure or burner problem. Be sure to reset the switch after correcting the failure condition.

**6 Red Flashes:** This indicates that after the furnace was operating, the pressure switch opened 4 times during the call for heat. If the main blower is in a "delay on" mode it will complete it, and any subsequent delay off period. The furnace will lock out for one hour and then restart.

**7 Red Flashes:** This fault code indicates that the flame could not be established. This no-light condition occurred 3 times (2 retries) during the call for heat before locking out. Low gas pressure, faulty gas valve, faulty hot surface ignitor or burner problem may cause this code. The furnace will lock out for one hour and then attempt another heating cycle if a call for heat is still present.

**8 Red Flashes:** This fault is indicated if the flame is lost 5 times (4 recycles) during the heating cycle. This could be caused by low gas pressure or faulty gas valve. The furnace will lock out for one hour and then attempt another heating cycle if a call for heat is still present.

**9 Red Flashes:** Indicates reversed line voltage polarity or grounding problem. Both heating and cooling operations will be affected. Check polarity at the furnace and breaker panel. Check furnace grounding. Check that the flame probes are not shorted to chassis.

**10 Red Flashes:** Gas valve is energized with no call for heat. Check the gas valve and gas valve wiring.

**11 Red Flashes:** This indicates that a primary or auxiliary limit switch has opened its normally closed contacts and has remained open for more than five minutes. This condition is usually caused by a failed blower motor or blower wheel.

**12 Red Flashes:** This code indicates an open ignitor circuit, which could be caused by a disconnected or loose wire or by a cracked or broken igniter.

**Soft lockout:** This control includes a soft lockout that resets automatically after 1 h. This provides protection for an unoccupied structure if a temporary condition exists causing a furnace malfunction. An example of this is a temporary interruption in the gas supply that prevents the furnace from lighting. The control keeps trying to light each hour and resumes normal operation if the gas supply is restored.

**Hard lockout:** Some fault conditions result in a hard lockout, which requires power to the control to be turned off and back on to reset the control. The control does not automatically restart.

**WARNING! HOT SURFACE IGNITION SYSTEM**

Do not attempt to light this furnace by hand (with a match or any other means). There may be a potential shock hazard from the components of the hot surface ignition system. The furnace can only be lit automatically by its hot surface ignition system.

**WARNING!**

Never bypass any safety control to allow furnace operation. To do so will allow furnace to operate under potentially hazardous conditions. Do not try to repair controls. Replace defective controls with UPG Source 1 Parts.

Never adjust pressure switch to allow furnace operation.

## Last ERROR Button

---

The control is equipped with memory that will store up to five error codes to allow a service technician to diagnose problems more easily. The memory will be retained even if power to the furnace is lost. This feature should only be used by a qualified service technician. The control stores up to five separate error codes. If more than five error codes have occurred since the last reset, only the five most recent faults will be retained. The furnace control board "LAST ERROR" button is used to retrieve error codes. This function will only work if there are no active thermostat signals. Any call for heating, cooling or continuous fan must be terminated before attempting to retrieve error codes.

Error codes are retrieved by pressing the **LAST ERROR button**. The LED on the control will flash the error codes that are in memory, starting with the most recent. There is a two-second pause between each flash code. After the error codes have been displayed, the LED resumes the normal slow green flash after a five second pause. To repeat the series of error codes, push the button again. If there are no codes in memory, the LED will flash two green flashes. To clear the memory, push the LAST ERROR button and hold it for more than five seconds. The LED will flash three green flashes when the memory has been cleared, then will resume the normal slow green flash after a five-second pause.

## Flame Current

---

The flame sensor proves the presence of flame during the trial for ignition. The flame sensor consists of a metal flame rod and a ceramic insulator. The flame sensor must be immersed in the flame.

During a call for heat, the flame sensor is energized with 120 volts AC from the furnace control board. In the presence of flame, this AC voltage is rectified through the flame to DC current. This rectified signal is read in DC microamps, but for ease of service, may be read on the furnace control board "test pad" with a multimeter set to DC Volts. 1 DC Volt = 1 Microamp (uA).

Normal uA values are in the 2-4 uA range, with a minimum of .1 uA required for flame proof. There are many factors that cause a low microamp signal. These factors include:

- Line voltage polarity must be correct.
- A dedicated ground wire that runs from the furnace junction box to the breaker panel.
- The flame sensor must be clean and in the flame. If cleaning is required, use steel wool.
- The ceramic must be intact with no cracks.
- AC voltage must be present between the flame sensor and ground.

## Hot Surface Ignitor (HSI)

---

If not glowing during warm up, check the ignitor resistance when cold, it should be approximately 40 – 80 ohms cold.

Verify that the correct line voltage is being supplied to the ignitor during warmup. This can be measured by setting a multimeter to AC Volts and measuring the AC voltage available to the ignitor at the plastic plug connector that connects the ignitor to the furnace control board.

## Gas Valve

---

The valve must have the proper gas pressure available on the inlet side, and properly set up manifold pressure on the outlet side to function properly. When checking supply/inlet pressure have other nearby or large gas appliances operating to detect possible pressure reduction.

The gas valve used in the 33" single stage gas furnace, is energized with 24 volts AC from the furnace control board during the trial for ignition after the ignitor warmup period.

## Burners

---

Discoloration on heat exchanger vestibule may indicate misalignment of burners. Delayed ignition may indicate blockage of crossover 'wings' of burners.



## Line Voltage Supply

---

For any modern electronic ignition furnace to work properly, it must have:

- A dedicated electrical circuit. Gas furnaces require their own power supply without any other loads connected.
- Correct Polarity: Line 1 – Hot, must be attached to the black power lead of the furnace.
- Neutral: The neutral/common of line voltage must be connected to the white power lead of the furnace.
- Good/Clean Dedicated Ground: It is absolutely necessary to have a dedicated ground wire run back to ground on the electrical panel.

## Safety Switches

---

Never bypass any safety device. The position of a safety switch (such as a limit switch, rollout switch, or pressure switch) may be verified using one of two preferred methods.

- With an AC voltmeter, take a voltage reading across the terminals of the switch. A closed switch will indicate zero (0) volts AC. An open switch is indicated by the applied voltage displayed on the meter.
- Turn system power off, disconnect the wiring connected to the switch, and take a resistance reading across the switch with an ohmmeter. An open switch will be indicated as an “infinite” or “open” circuit with an ohmmeter. A closed switch will be indicated as “continuity” or zero ohms resistance.

## Pressure Switch Diagnosis (General)

---

The pressure switch is present to verify that the induced draft motor is coming up to speed and that there are no restrictions within the vent system. Pressure switches are commonly normally open and close upon normal operation after the inducer motor is energized, allowing the ignition sequence to continue.

Information about the closure or “make” pressure of the switch is usually on the switch body. If not, check the literature for the furnace model being serviced.

Closure of the pressure switch contacts can be verified by taking a voltage reading across the switch. 24 volts will be read across an open switch, and will read zero volts if the switch is closed. The wiring to the switch may also be disconnected to test for continuity across the switch with an ohmmeter. A closed switch will read continuity or zero resistance with an ohmmeter.

If the switch is not closing with the inducer operating, the technician must determine if there is a problem with the switch itself, or if there is another problem causing the switch to not close. The best method of doing this is with a Magnehelic gauge or incline manometer. A scale of 0-5” w.c. will work well for testing pressure switches in most applications.

The Magnehelic or incline manometer should be teed into the pressure switch tubing on both sides using 1/8” tees. Doing so puts the Magnehelic gauge in parallel with the pressure switch, and it will read the same pressure that is being seen at the pressure switch.

After the Magnehelic gauge is connected to the pressure switch, the gauge tubing must be run outside the furnace cabinet and the panel must be put back in place. If this is not done, the gauge reading will not reflect actual system operating conditions.

Create a call for heat and observe the pressure on the gauge. If the reading on the gauge is in excess of the make point of the switch is not closing, it is defective and must be replaced.

If the reading on the gauge is a lower value than the make point of the pressure switch, a problem exists that is not allowing sufficient combustion air to flow through the furnace.

A common cause of this is obstruction in the intake or exhaust piping, which could be any of the following:

- Rocks, balls, or other items that may have been placed in the pipe.
- Snow or ice restrictions.
- Rodents, insects or insect nests
- Improper support of exhaust piping on condensing furnaces, allowing condensate to remain in the piping.
- Undersized piping, too long of piping run, or too many elbows in the piping run.

The best way to determine if one of these items is a problem is to disconnect the intake and exhaust piping from the furnace. If the reading on the gauge greatly increases with the piping disconnected, the problem lies in the vent system. Reconnect the intake and exhaust upon completion of testing.

If the pressure reading on the gauge doesn’t increase enough to close the pressure switch even with the vent pipe disconnected, check for the following:

- Pressure switch tubing cracked, kinked, obstructed or disconnected
- Inducer wheel loose on the motor shaft
- Blades missing on the inducer wheel
- Tight bearings on the inducer motor
- Restricted pressure tap ports
- Blocked condensate drains

Never attempt to adjust a pressure switch or use a different switch than the one specified for the furnace model being serviced. Never attempt to jump the switch to allow the furnace to operate. Doing so could allow the furnace to operate under hazardous conditions leading to bodily injury, property damage or loss of life.

## Limits and Rollout Switches

---

Limits are used to stop furnace operations in the event of abnormal temperatures.

The primary limit is mounted to the vestibule panel. It usually is an auto-reset switch that opens a control circuit in the event that there is excessive heat in the heat exchanger section.

If the primary limit is tripping, first verify that the gas input and manifold pressures are correct. Next, ensure that the blower speed is set up correctly to provide the proper temperature rise across the furnace. If the blower speed is already on high and the temperature rise is above the allowable range, most likely a problem lies in the air distribution system and should be investigated by measuring the ESP of both the supply and return ductwork.

Check that the furnace is properly sized for the application. A grossly oversized furnace will tend to bump limit before the thermostat is satisfied, especially in combination with undersized ductwork.

Verify that the blower is functioning properly, and the blower wheel is clean. Make sure that nothing is deflecting airflow away from the limit, such as cabinet insulation or debris.

These items will resolve 99% of limit trip problems. If the limit switch itself is defective, be sure to replace it with a limit with the exact same limit settings. Installing incorrect limits may cause the furnace to operate under unsafe conditions, and the technician or the technician's company will be liable for the damage or loss of life that may result.

Rollout limits are located in the burner area. Depending on the model, there may be one or more rollout switches present. The rollout limit will open in the event of an abnormal flame pattern. The flames must fire directly through the vestibule panel and into the heat exchanger. If burners are misaligned, gas pressure is incorrect, orifices are the incorrect size or misaligned, or a restriction or leak is present in the heat exchanger, rollout can occur.

A rollout switch trip needs to be thoroughly investigated and corrected. Never bypass any limit switch to allow operation to continue. Doing so can result in hazardous conditions leading to bodily injury, property damage or loss of life.

## **Blower Door Switch**

---

Taping or bypassing the door switch can cause a serious safety risk. If the door switch has been taped closed during service, be sure that the tape is removed upon completion of the repair and reinstalling the blower compartment panel.

## Condensate Drainage

---

Check the condensate drainage system for blocked, cracked and kinked tubing.

Ensure that the drain is not “double trapped” preventing the proper drainage of condensate. If the condensate drain line becomes plugged or if a secondary trap is placed in the drain piping, the secondary heat exchanger and inducer motor will fill with water and pressure switch trips will occur.

The condensate drain from the furnace may be connected in common with the drain from an air conditioning coil only if allowed by local code.

## Standard ECM Motor – Connections and Communications

---

There is one connection block on the Standard ECM motor with two rows of terminals. The terminals are two different sizes.

The power inputs (high voltage) to the motor connect through the 3/16" terminals on the following terminals:

- (L) – Line 1
- (G) – Ground
- (N) – Neutral or Line 2

The line voltage is present at these terminals whenever the system is powered, regardless of thermostat demand. The control inputs (low voltage) to the motor connect through the 1/4" terminals. Terminal "C" is used for common and terminals 1-5 are used to select airflow settings programmed into the motor.

Communication to the Standard ECM motor is the low voltage 24 volts AC that is provided to taps 1 through 5. The purpose of this voltage is to communicate to the motor only, not to operate it. The 24 volts AC provided to each tap is a communication signal used to select five different torque values. The motor's control board uses this signal to determine which torque value should be delivered, and then uses the line voltage (high voltage that is continuously connected) to operate the motor according to that program.

Each motor has a unique program. If the motor taps are changed in the same way on two different unit models, the results will differ. The tap settings must never be changed to adjust airflow without checking the air flow charts for the system installed.

Example 1:

If tap 1 provides airflow for the heating mode, and the torque required to provide the airflow for a proper temperature rise in that furnace is 76% of the maximum torque ability of the motor, that will be the value programmed into the tap.

Example 2:

If tap 2 provides the airflow for the cooling mode, and the torque required to provide the airflow for a specified tonnage is 88% of the maximum torque ability of the motor, then that will be the value programmed into the tap.

Even though changing tap connections does change the speed of the motor, it is important, in theory at least, to understand that these are programmed levels of torque. Each tap can have a unique amount of torque programmed for a specific purpose.

These examples also do not show a tap specifically programmed for continuous fan selection. Depending on the application, the heating or cooling selection may be used for continuous fan blower speed. The percentage used for continuous fan operation is found in the Installation Manual for each unit.



## Servicing the Standard ECM Motor

---

The Standard ECM Motor is operated by 115 volts AC. Applying incorrect line voltage to the Standard ECM motor may prevent the motor from operating or may cause damage to the motor.

The Installation Manual and wiring schematics must be consulted for proper set up, wiring, operation and troubleshooting. Checking all system limits, rollouts, and safeties before troubleshooting the motor is important.

Troubleshooting this motor is simple if the following information is known:

1. Which tap(s) have programs and what are their purposes (heating airflow, cooling airflow, continuous fan airflow)?
2. Where on the controls or circuit board do the line voltage and control voltage come from?
3. What is the sequence of operation of the controls or circuit boards (when the control voltage is sent to the motor from each thermostat demand and if there are any delays)?

Troubleshooting the voltage at the Standard ECM motor comes down to two simple factors:

1. Line voltage (115 volts AC), which must be present at all times with or without a demand for heating, cooling or continuous fan. Make sure proper line voltage is present between the “L” and “N” terminals as shown for the specific model being serviced.

Line voltage must be present at the motor with or without a demand from the thermostat. The allowable voltage variance is between 98 and 132 volts AC.

2. 24 volts AC low (control) voltage at the appropriate tap, with the appropriate thermostat demand call. Control voltage is present between terminals “1” through “5” and the “C” terminal as shown in Figure 6-6, depending on which terminal is receiving control voltage.

The allowable voltage variance can be as much as +/- 10% of the nominal 24 volts AC. If the voltage is present below this range, confirm that the control voltage is present at the unit transformer, and at the thermostat low voltage connections on the unit control board.

If the motor is operating with high voltage present at the motor and low (control) voltage present on a programmed tap, then any airflow issues must be addressed first. This includes high or low temperature rise, main limit trips, freezing coils or compressor overload tripping.

The Standard ECM is not a constant CFM motor. Airflow will decrease if static pressure rises too high in the system.

The Installation Manual provides low voltage wiring connection diagrams. If high voltage and the low (control) voltage are present at the appropriate electrical connections, but the motor will not operate, the motor must be replaced. A direct replacement motor from the manufacturer for the same model and size unit is required.

## Replacing the Standard ECM Motor

---

The Standard ECM motor is a one-piece motor that is replaced as a whole and is not field repairable.

When replacing the Standard ECM motor, use a direct replacement for the specific unit model. If a bellyband is used for mounting, the band should not be in the area identified in the “Keep Out Area”.

The wheel key must be tightened on the flat side of the motor shaft with the blower wheel centered in the housing.

If the wheel sits too close to the motor when centered or if the wheel cannot be centered because it hits the motor, the motor must be adjusted in the belly band. The blower assembly must be reinstalled into the HVAC system.

All wires and plugs must be reconnected to the motor by confirming connection to proper terminals per demand.

A drip-loop must be formed so water cannot enter the motor by draining down the cables. Condensate or droplets can accumulate in the harness and may find their way into the motor.

## Duct System

---

Improperly sized ducts and restrictions in the duct system can lead to numerous system problems.

There are limitations to the airflow the blower may provide if installed in systems with improperly sized ductwork or other system restrictions. The measurement is of utmost importance to determine if the furnace will be able to perform under its designed external static pressure, or ESP.

On the supply (positive) side of the blower, this pressure is pushing out in all directions on the interior of the supply system. On the return (negative) side of the blower, this pressure is pulling inward on the interior of the return system. Restrictions in the duct system such as undersized duct, dirty filters or evaporator coil, or closed or blocked registers will cause the external static pressure to increase. As the external static pressure increases, the furnace blower's ability to move air decreases. Most residential furnaces (including the 33" gas furnaces) are designed to deliver their rated airflow up to .5" w.c. total external static pressure.

A common tool of choice for measuring ESP is the Magnehelic gauge or incline manometer. The example below illustrates use of the Magnehelic gauge, although the measurement procedure (probe placement) will be identical with an incline manometer.

## Using the Magnehelic

The Magnehelic gauge has two ports, labeled “High” and “Low”.

The “High” port causes the value shown by the needle to increase if pressure is being put into the port. This port is connected to the supply side of the system.

The port marked “Low” causes the value shown by the needle to increase if there is a negative pressure on the port. This port is connected to the return side of the system.

### Supply Static Measurement

To measure the supply static pressure, connect the Magnehelic gauge probe to the port marked “High”. The probe should be inserted immediately off the supply duct connection, under the evaporator coil if possible. This will allow measurement of the supply static and resistance to airflow imposed by the evaporator coil, supply duct, fittings, and registers. The supply system, when properly sized, should be near .1” w.c. (without the evaporator coil). A clean, dry evaporator coil will add about .2” w.c. static, bringing the supply static to a total of .3” w.c. (.1” + .2” = .3”).

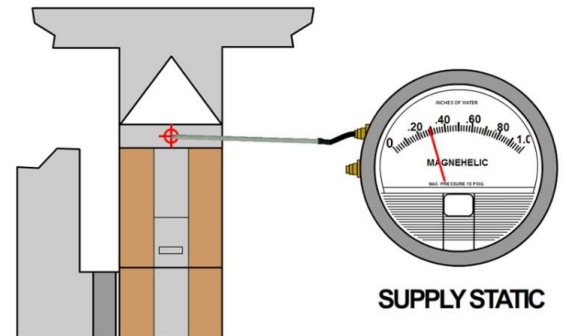

### Return Static Measurement

To measure the return static pressure, connect the Magnehelic probe to the port marked “low”. The probe should be inserted between the filter and the furnace. This will allow you to read the return static and resistance to airflow imposed by the filter, return drop, return ductwork, fittings, and grilles.

If access cannot be obtained between the furnace and the filter, a non-invasive place the measure return static is through a grommet on the side of the furnace cabinet in the blower section.

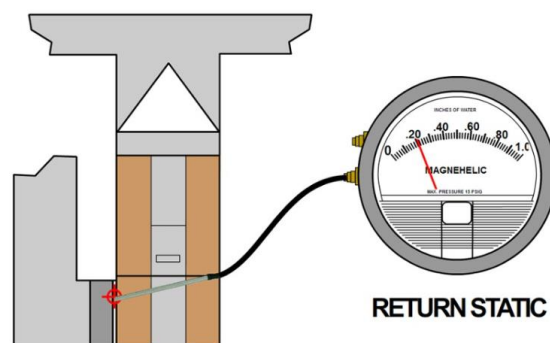

## Total Static Measurement

The total external static pressure can be determined either by taking the supply and return statics individually and adding them, or simply by using two probes and noting the reading on the gauge.

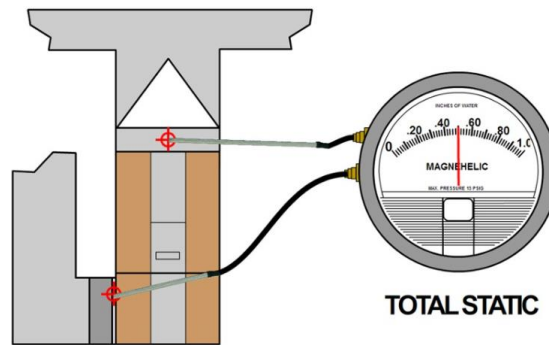

## ESP as a Diagnostic Tool

In addition to using the Magnehelic gauge to properly set up the blower speed for air conditioning, it can also be used to diagnose problems within the air distribution system.

For instance, if the furnace is continuously tripping high limit even with the blower on high speed, the Magnehelic gauge will help indicate where the problem lies. Measure the supply and return static pressures as previously mentioned. If the supply static is high, take an additional reading after the evaporator coil. The difference between the reading before the coil and after the coil should be no more than approximately .2-.25" w.c. when the coil is dry (check the specs for the coil that is being used) or approximately .3" w.c. when the coil is wet. If the drop is much greater than that, the plenum should be opened to visually inspect the evaporator coil, as it may be restricted.

If the static pressure drop across the coil is within limits and the reading downstream of the coil is far more than .1"-.15" w.c., the supply duct system may be restricted or undersized.

If the return static is high, verify that the filter is clean. A reading can also be taken upstream of the return air filter to determine if a problem lies in the return system. If the return static is far more than .1-.15" w.c., the return system could be restricted or undersized.

08

---

# Maintenance

## Introduction

---

Gas furnaces should be cleaned and checked once a year before the start of the heating season.

## Blower Assembly

---

Even with adequate filters properly in place, blower wheels and motors will become dust covered after months of operation. The entire blower assembly should be inspected annually. If the motor and wheel are heavily coated with dust, they can be brushed and cleaned with a vacuum cleaner. In extreme conditions, a host can be used (after motor is removed) to clean the wheel.



## Blower Assembly Removal

- Turn off the external electrical power to the unit.
- Remove the bottom furnace panel
- Remove the two screws from the blower mounting rails. It is not necessary to remove the 12 pin and 4 pin plugs from the furnace control to make the blower assembly easier to remove. It may be necessary to loosen some of the wires. It should not be necessary to cut the ties.
- The blower assembly pulls completely out for service.



Blower Assembly Removal

## Motor Lubrication

---

The blower motor and inducer motor on the 33" single stage gas furnaces are permanently lubricated and require no periodic oiling. Check the horizontal play of the shaft for excessive wear.

## Burners

---

The main burners should be checked periodically for dirt accumulation. If cleaning is required, follow this procedure:

- Turn off the external electrical power to the unit.
- Remove the upper access panel.
- Turn off the gas supply at the manual shutoff valve and loose the ground union joint.
- Remove the flame sensor and igniter. Handle carefully.
- Disconnect wires to the rollout switch(es).
- Disconnect the gas ground union.
- Remove the screws that hold the manifold to the vestibule.
- Remove burners from the burner assembly.
- The burners may be cleaned by rinsing in hot water.
- Reassemble the burner assembly in the reverse order.

## Flame Sensor

---

Clean with fine to medium wool steel. Do not use emery cloth, which may leave residue on the sensor rod. Inspect for pitting, especially on LP gas applications.

## Primary Heat Exchanger

---

Under normal conditions, the interior of the primary heat exchanger should not require regular cleaning. If the furnace has been operating in a mild sooting condition, loose soot may be removed with a stiff wire brush and a vacuum.

If cleaning is required, use the following procedure:

- Turn off the manual gas valve external to the furnace.
- Turn off the external electrical power.
- Remove the upper access panel.
- Disconnect wires from flame sensor, rollout switches and HIS. Remove the sensor and HIS.
- Disconnect the gas union.
- Remove the screws that hold the manifold assembly to the vestibule panel and remove the assembly.
- Remove the burners as described above.
- Use a flexible wire brush to clean the inside of the primary heat exchanger tube. Push the brush as far into the heat exchanger tubes as possible. If the brush will not make it around the bends in the heat exchanger, vacuum loose scale and dirty from each tube. Use nitrogen or compressed air to loosen scale or dirty that may be stuck in the tubes. Be sure to wear safety glasses.

## Secondary Heat Exchanger (95% Models)

---

To inspect the underside of the secondary heat exchanger, remove the blower housing. If the owner has neglected to perform filter maintenance, dust and debris can be carefully removed with a vacuum. Use caution not to bend the fins on the heat exchanger.

Under normal conditions, the interior of the secondary heat exchanger should not require cleaning. If the furnace has been operating in a mild sooting condition, loose soot may be removed with a stiff wire brush and a vacuum. Access to the secondary heat exchanger tubes is gained by removing the inducer assembly and collector box from the outlet of the secondary heat exchanger. The turbulator strips may VERY CAREFULLY be removed during heat exchanger cleaning and MUST be carefully reinstalled upon completion of the cleaning process.

If the secondary heat exchanger has become very sooted due to improper gas side setup or low gas pressure, it must be replaced...do not attempt to clean a heavily sooted secondary heat exchanger.

## Vents and Combustion (95% Models) Piping

---

Gas furnaces require a watertight vent/air intake system. Inspect for unsealed joints, cracked pipe or blocked terminations. Horizontal runs require ¼ inch per foot slope back to the furnace. The termination outside must be clear of obstructions and 12" above grade or highest snow level. Be aware of shrubs or new construction (such as a deck) or other restrictions that may interfere with proper venting.

On 80% AFUE models, inspect the vent system for signs of deterioration, including corrosion at 90-degree elbows, which is indicative of condensation in the vent system. Condensation may be due to under firing, excessive airflow, oversized vent piping, vent connector, or oversized masonry chimney.

## **Condensate Collection (95% Models)**

---

Inspect all drain hoses inside the cabinet, condensate drain pan and condensate drain piping outside the furnace cabinet.

Do not neglect to inspect the condensate pump accessory if present. Rinse out and flush with clean water.



## **Vestibule and Blower Compartments**

---

The vestibule area and blower compartments should be vacuumed to remove all debris.

## Air Filters

---

Never operate gas furnaces without a suitable air filter. Filters used with the 33" single stage gas furnaces must be installed external to the furnace casing.

DO NOT attempt to install filters inside the furnace cabinet. The filters should be checked and/or replaced every 3 months or as needed. Gas furnaces are not to be used for temporary heat during construction.

High-velocity filters (hogs' hair) may be cleaned with a vacuum cleaner or washed. Be sure to shake off excess water and allow the filter to completely dry before re-installing the filter.

## Replacing Filters

---

When replacing the filter(s), be sure to install the right size filter for the furnace. Dirty filters greatly restrict the flow of air and may cause damage to the moving parts of the furnace. If the filters become clogged the heat exchangers and blower motor could overheat resulting in a potentially dangerous situation.

Replace throw away filter(s) with the same size new filter(s).

## Thermostats

---

Thermostats must be level and secured to the wall. Gently blow out any dust accumulation and check exposed contacts of snap acting thermostats for deterioration.

Verify the heat anticipator setting (if available on the thermostat used). The heat anticipator is set to the value read after the circulating air blower is energized during the heating cycle.

Some electronic thermostats do not have adjustable heat anticipators. They may have a cycle rate adjustment setting rather than anticipator setting, and in most cases require no adjustment.